

FIFE SE-31 MINI-ULTRASONIC SENSOR

MAXCESS®

MAGPOWR



TIDLAND

Our smallest ultrasonic sensor, the SE-31 is ideal for guiding both clear and opaque materials. This temperature stabilized sensor is unaffected by optical variation or ambient light, eliminating the need for multiple sensors, and increasing productivity.

The SE-31 has a control range of 7.62 mm (0.3 inch), and a sensing gap of either 25.4 mm or 50.8 mm (1 inch or 2 inches). Improved circuitry reduces the effect of standing waves and temperature variations, which improves the overall operational performance of this sensor.



GENERAL SPECIFICATIONS

Product Name SE-31 Mini-Ultrasonic Sensor	Output Signal 0 to 10 mA
Linearity 5% nominal maximum error	Weight 168 grams (6 ounces)
Plane Change 5% nominal maximum error	Temperature Range 5° to 60° C (41° to 140° F)
Power Required 10 to 15 VDC	

KEY FEATURES

- Compact, versatile sensor will sense the thinnest and clearest films, as well as most opaque webs
- Immune to web plane changes and unaffected by optical variation or ambient light, including sunlight
- Will not affect photosensitive materials
- No special sensor orientation is required to avoid the effect of standing waves
- Closed face transducer – splash proof
- Compatible with all Fife controllers
- Standard sensing gap of 25.4 mm or 50.8 mm (1 inch or 2 inches) and a control range of 7.62 mm (0.3 inch)
- Flexible mounting and positioning assemblies ensure quick and easy installation
- Electrostatic discharge protected

FIFE SE-31 MINI-ULTRASONIC SENSOR

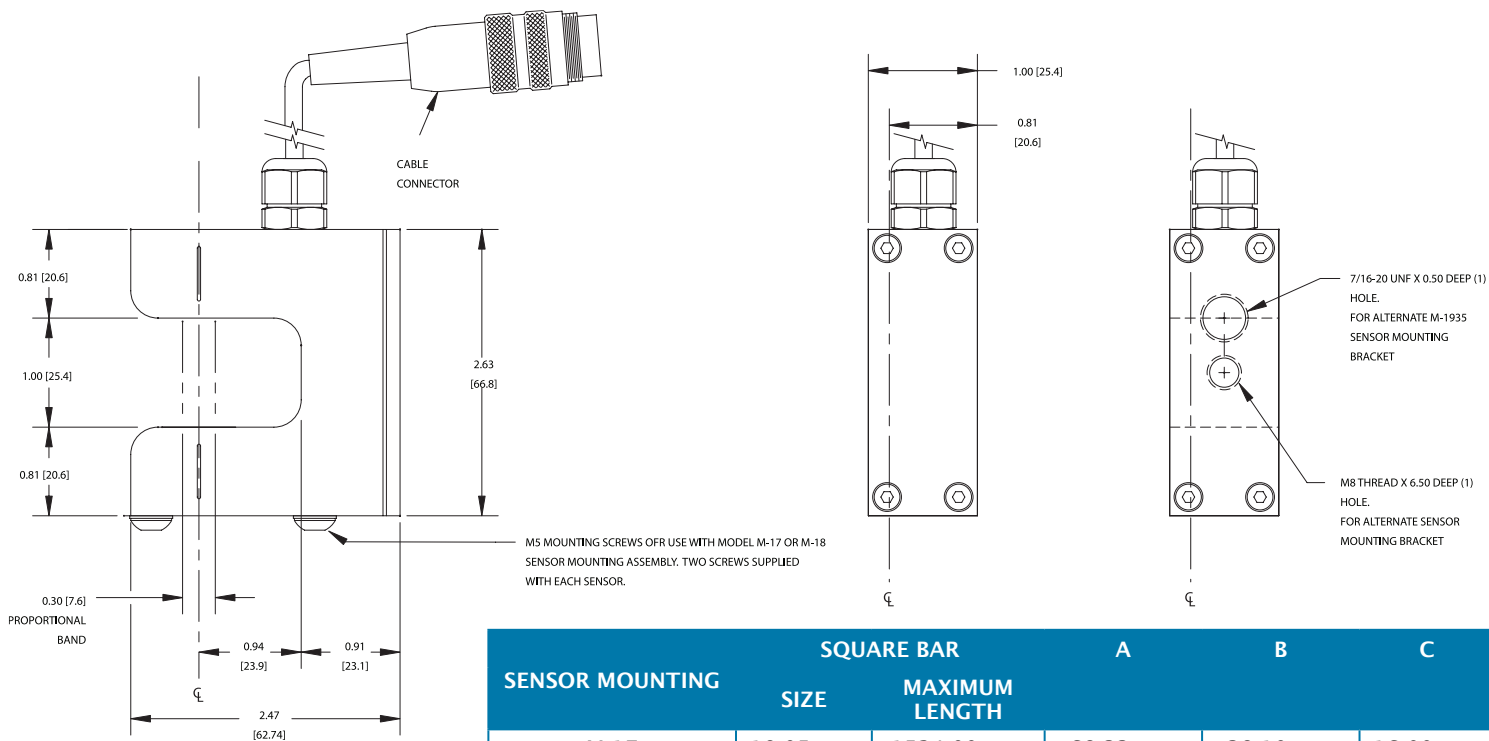

SENSOR MOUNTING	SQUARE BAR		A	B	C
	SIZE	MAXIMUM LENGTH			
M-17	19.05 mm (0.75 inch)	1524.00 mm (60.00 inches)	68.33 mm (2.69 inches)	38.10 mm (1.50 inches)	16.00 mm (0.63 inch)
M-18	25.4 mm (1 inch)	2184.40 mm (86.00 inches)	71.63 mm (2.82 inches)	50.80 mm (2.00 inches)	19.05 mm (0.75 inch)

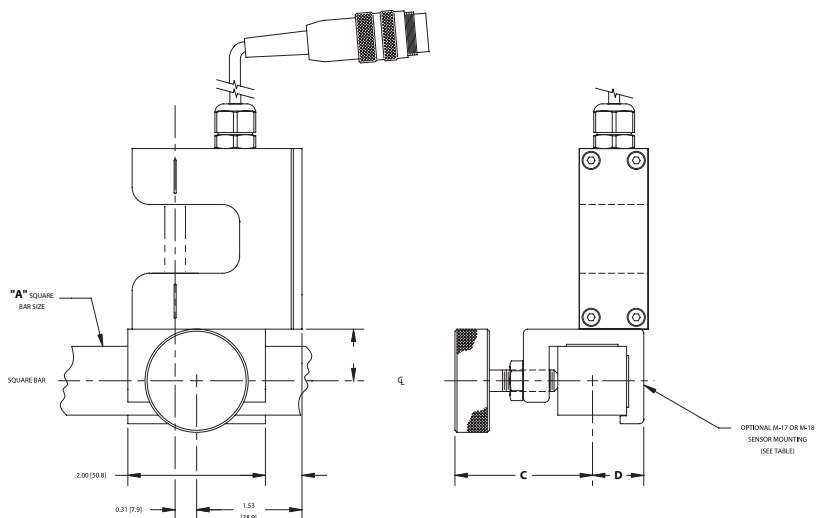

Dimensions shown in parenthesis are in inches.



NORTH, CENTRAL AND SOUTH AMERICA

Tel +1.405.755.1600
Fax +1.405.755.8425
sales@maxcessintl.com
www.maxcessintl.com

INDIA

Tel +91.22.27602633
Fax +91.22.27602634
india@maxcessintl.com
www.maxcess.in

EUROPE, MIDDLE EAST AND AFRICA

Tel +49.6195.7002.0
Fax +49.6195.7002.933
sales@maxcess.eu
www.maxcess.eu

JAPAN

Tel +81.43.421.1622
Fax +81.43.421.2895
japan@maxcessintl.com
www.maxcess.jp

CHINA

Tel +86.756.881.9398
Fax +86.756.881.9393
info@maxcessintl.com.cn
www.maxcessintl.com.cn

KOREA, TAIWAN AND SE ASIA

Tel +65.9620.3883
Fax +65.6235.4818
asia@maxcessintl.com