



**Model Number**

**LA39/LK39/31/40a/116**

Thru-beam sensor  
with terminal compartment

**Features**

- Light/dark ON, switchable
- Supplied with mounting accessory
- Degree of protection IP67

**Product information**

Series 39 sensors are characterized by their high performance level, compact housing design, and variety of available versions. These include thru-beam sensors with a 20 m detection range, retroreflective sensors with polarization filter for a 5 m detection range, energetic diffuse mode sensors with an 800 mm and 2000 mm detection range, and a background suppression sensor with 500 mm detection range. Fitted in a robust plastic housing, this series is ideal for tough industrial applications.

The sensors are supplied with 10 V to 30 V DC, or 24 V to 240 V AC/DC. Various transistor and relay outputs are available as signal outputs. Standard features include pre-fault diagnostics and pre-fault output. The switching element function can be changed using the light/dark switch.

**Dimensions**

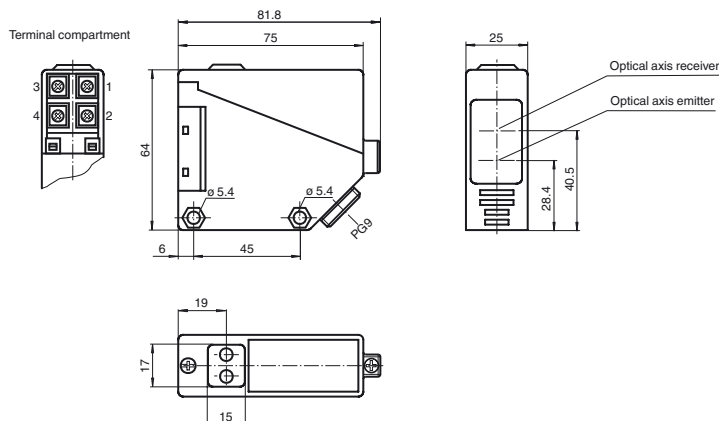

**Electrical connection**

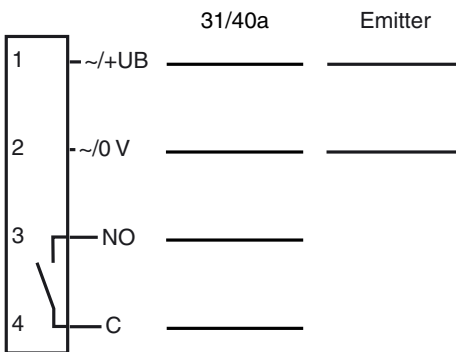

**Indicators/operating means**

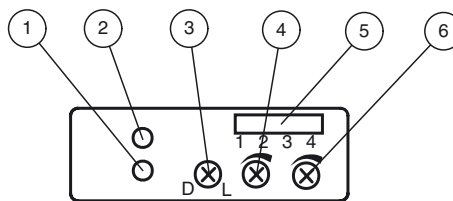

1	Operating display red (Transmitter)
1	Pre-fault indication red (Receiver)
2	Switch state yellow
3	Light/dark on switch
4	Sensitivity adjustment
5	Timer mode switch (version -Z)
6	Time adjuster (version -Z)

Release date: 2018-07-31 14:35 Date of issue: 2018-07-31 088806\_eng.xml

**Technical data****System components**

Emitter	LA39/116
Receiver	LK39/31/40a/116

**General specifications**

Effective detection range	0 ... 20 m
Threshold detection range	25 m
Adjustment range	2 ... 25 m
Reference target	receiver
Light source	IRED
Light type	modulated infrared light
Ambient light limit	IEC / EN 60947-5-2 , 10000 Lux

**Functional safety related parameters**

MTTF <sub>d</sub>	916 a
Mission Time (T <sub>M</sub> )	20 a
Diagnostic Coverage (DC)	0 %

**Indicators/operating means**

Operation indicator	LED red (emitter)
Function indicator	LED yellow: switching state LED red: pre-fault indication
Control elements	Sensing range adjuster, light-on/dark-on changeover switch

**Electrical specifications**

Operating voltage	U <sub>B</sub>	12 ... 240 V DC / 24 ... 240 V AC (50 ... 60 Hz)
Ripple		10 %
No-load supply current	I <sub>0</sub>	≤ 60 mA receiver and emitter
Protection class		II, rated voltage ≤ 250 V AC with pollution degree 1-2 according to IEC 60664-1 Caution! The protection class 2 is only valid when the terminal compartment is closed. output circuit has basic insulation to control circuit according to IEC/EN 61140
Power consumption	P <sub>0</sub>	≤ 3 VA
Time delay before availability	t <sub>v</sub>	≤ 300 ms

**Output**

Switching type	light/dark on	
Signal output	1 relay output	
Switching voltage	max. 240 V AC ; 150 V DC	
Switching current	max. 3 A	
Switching power	DC: max. 90 W AC: max. 750 VA	
Switching frequency	f	≤ 25 Hz
Response time		≤ 20 ms

**Ambient conditions**

Ambient temperature	-25 ... 55 °C (-13 ... 131 °F)
Storage temperature	-40 ... 70 °C (-40 ... 158 °F)

**Mechanical specifications**

Housing width	25 mm
Housing height	64 mm
Housing depth	75 mm
Degree of protection	IP67
Connection	terminal compartment PG9, ≤ 2.5 mm <sup>2</sup>
Material	
Housing	PBT
Optical face	PMMA
Mass	Emitter: approx. 90 g receiver: approx. 110 g

**General information**

Scope of delivery	Mounting aid
-------------------	--------------

**Compliance with standards and directives**

Directive conformity	EMC Directive 2004/108/EC
EMC Directive 2004/108/EC	EN 60947-5-2:2007+A1:2012 IEC 60947-5-2:2007+A1:2012
Standard conformity	
Product standard	EN 60947-5-2:2007 IEC 60947-5-2:2007

**Approvals and certificates**

EAC conformity	TR CU 020/2011 TR CU 004/2011
CCC approval	Certified by China Compulsory Certification (CCC)
Approvals	CE

**Operating principle**

The thru-beam sensor requires a pair of devices for operation, comprising a light transmitter and a light receiver. The emitter and receiver must be arranged in optical alignment with each other. The infrared light from the emitter is detected by the receiver and evaluated.

**Accessories****OMH-RL39**

Mounting bracket for RL39 series  
Sensors

Other suitable accessories can be found at  
[www.pepperl-fuchs.com](http://www.pepperl-fuchs.com)

Curves/Diagrams

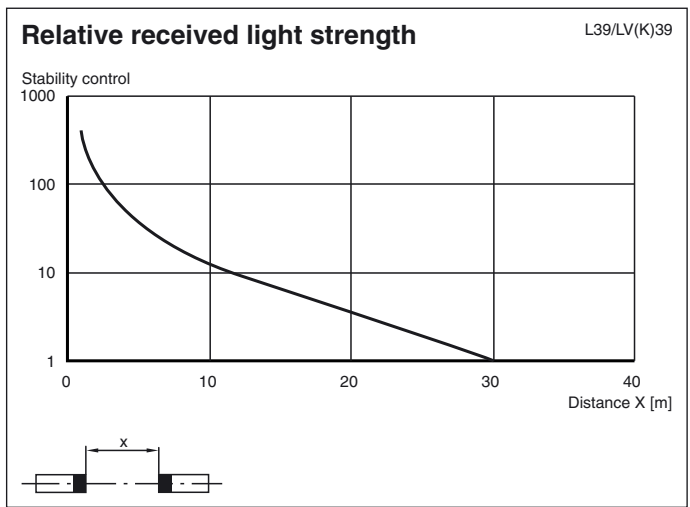
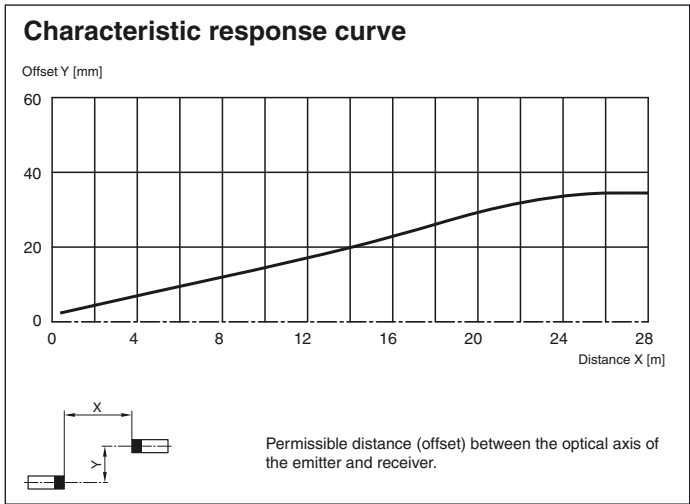

Release date: 2018-07-31 14:35 Date of issue: 2018-07-31 088806\_eng.xml

Refer to "General Notes Relating to Pepperl+Fuchs Product Information".

Pepperl+Fuchs Group  
www.pepperl-fuchs.com

USA: +1 330 486 0001  
fa-info@us.pepperl-fuchs.com

Germany: +49 621 776 4411  
fa-info@de.pepperl-fuchs.com

Singapore: +65 6779 9091  
fa-info@sg.pepperl-fuchs.com