

Features

- 4-channel isolated barrier
- 24 V DC supply (bus powered)
- Dry contact or NAMUR inputs
- 4 relay contact outputs
- Line fault detection (LFD)
- Up to SIL 2 acc. to IEC 61508

Function

This isolated barrier is used for intrinsic safety applications. It transfers digital signals (NAMUR sensors/mechanical contacts) from a hazardous area to a safe area.

The proximity sensor or switch controls two form A normally open relay outputs for the safe area load. The module output changes state when the input signal changes state. The normal output state can be reversed with the selector switches on the side of the unit.

Line fault detection (LFD) can be selected or disabled via a selector switch.

During an error condition, the relay reverts to its de-energized state and the LEDs indicate the fault. A separate fault output bus is available. The fault conditions can be monitored via a Fault Indication Board.

This module mounts on a HiD Termination Board.

Assembly

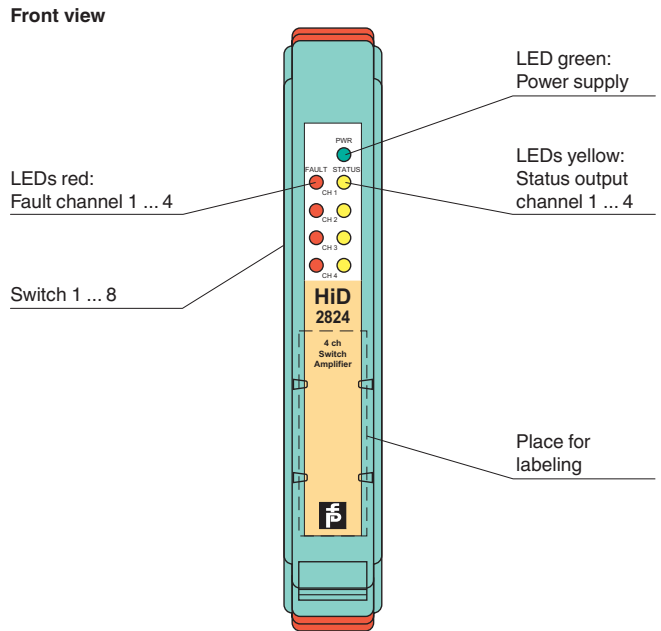

SIL 2



Connection

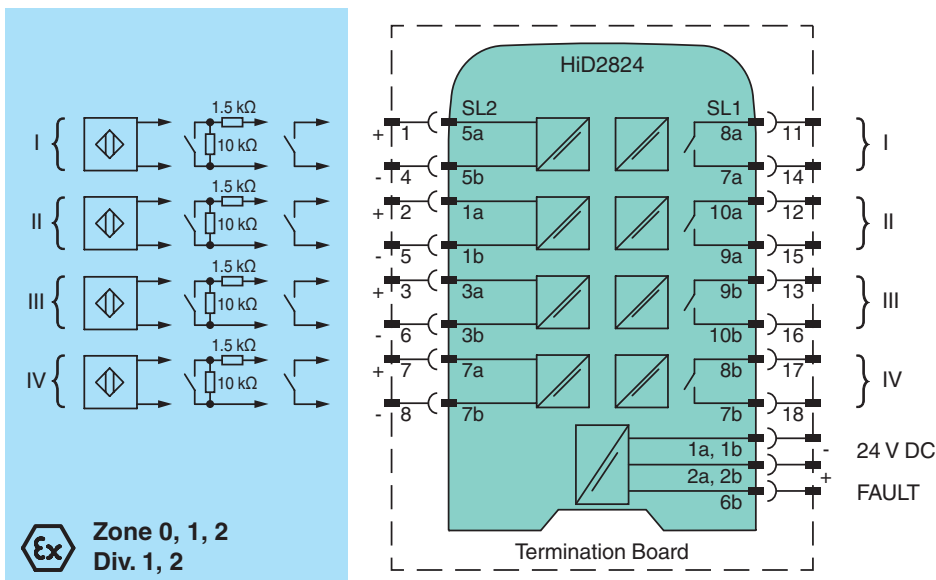

Release date 2018-05-08 13 Date of issue 2018-05-08 121451_eng.xml

Refer to "General Notes Relating to Pepperl+Fuchs Product Information".

Pepperl+Fuchs Group
www.pepperl-fuchs.com

USA: +1 330 486 0002
pa-info@us.pepperl-fuchs.com

Germany: +49 621 776 2222
pa-info@de.pepperl-fuchs.com

Singapore: +65 6779 9091
pa-info@sg.pepperl-fuchs.com

General specifications		
Signal type		Digital Input
Functional safety related parameters		
Safety Integrity Level (SIL)		SIL 2
Supply		
Connection		SL1: 1a(-), 1b(-); 2a(+), 2b(+)
Rated voltage	U_r	20.4 ... 30 V DC bus powered via Termination Board
Rated current	I_r	15 mA at 24 V, relay energized (per channel)
Power dissipation		0.35 W at 24 V (per channel)
Input		
Connection side		field side
Connection		SL2: 5a(+), 5b(-); 1a(+), 1b(-); 3a(+), 3b(-); 7a(+), 7b(-)
Rated values		acc. to EN 60947-5-6 (NAMUR)
Connectable sensor types		potential free contact or proximity sensor
Switching point		contact open 0.2 ... 1.2 mA, contact closed 2.1 ... 6.5 mA
Line fault detection		breakage 0 ... 0.2 mA, short-circuit 6.5 mA ... maximum value
Output		
Connection side		control side
Connection		SL1: 8a, 7a; 10a, 9a; 10b, 9b; 8b, 7b
Output		signal: relay SPST per channel, phase selectable
Response time		20 ms
Contact loading		50 V DC / 0.5 A non-inductive
Mechanical life		10 ⁷ switching cycles
Fault indication output		
Connection		SL1: 6b
Output type		open collector transistor (internal fault bus)
Transfer characteristics		
Switching frequency		< 10 Hz
Galvanic isolation		
Output/power supply		functional insulation acc. to DIN EN 50178, rated insulation voltage 50 V _{eff}
Output/Output		functional insulation acc. to DIN EN 50178, rated insulation voltage 50 V _{eff}
Indicators/settings		
Display elements		LEDs
Control elements		DIP-switch
Configuration		via DIP switches
Labeling		space for labeling at the front
Directive conformity		
Electromagnetic compatibility		
Directive 2014/30/EU		EN 61326-1:2013 (industrial locations)
Conformity		
Galvanic isolation		EN 50178:1997
Electromagnetic compatibility		NE 21:2006 For further information see system description.
Degree of protection		IEC 60529:2001
Ambient conditions		
Ambient temperature		-20 ... 60 °C (-4 ... 140 °F)
Relative humidity		5 ... 90 %, non-condensing up to 35 °C (95 °F)
Mechanical specifications		
Degree of protection		IP20
Mass		approx. 140 g
Dimensions		18 x 106 x 128 mm (0.7 x 4.2 x 5 inch)
Mounting		on Termination Board
Coding		pin 1 and 2 trimmed For further information see system description.
Data for application in connection with hazardous areas		
EU-Type Examination Certificate		CESI 02 ATEX 086
Marking		⊕ II (1)G [Ex ia Ga] IIC , ⊕ II (1)D [Ex ia Da] IIIC
Input		Ex ia, Ex iaD
Voltage	U_o	13.2 V
Current	I_o	20 mA
Power	P_o	66 mW
Supply		
Maximum safe voltage	U_m	250 V AC (Attention! U_m is no rated voltage.)
Type of protection [Ex ia]		

Release date 2018-05-08 08:13 Date of issue 2018-05-08 121451_eng.xml

Refer to "General Notes Relating to Pepperl+Fuchs Product Information".

Pepperl+Fuchs Group
www.pepperl-fuchs.com

USA: +1 330 486 0002
pa-info@us.pepperl-fuchs.com

Germany: +49 621 776 2222
pa-info@de.pepperl-fuchs.com

Singapore: +65 6779 9091
pa-info@sg.pepperl-fuchs.com

Certificate	PF 11 CERT 2109 X
Marking	Ⓔ II 3G Ex nA nC IIC T4 Gc
Galvanic isolation	
Input/input	safe electrical isolation acc. to EN 60079-11:2007, voltage peak value 60 V
Input/Output	safe electrical isolation acc. to EN 60079-11: 2007, voltage peak value 375 V
Input/power supply	safe electrical isolation acc. to EN 60079-11: 2007, voltage peak value 375 V
Directive conformity	
Directive 2014/34/EU	EN 60079-0:2012+A11:2013 , EN 60079-11:2012 , EN 60079-15:2010
International approvals	
CSA approval	
Control drawing	366-005CS-12B (cCSAus)
IECEX approval	IECEX TUN 04.0012
Approved for	[Ex ia] IIC
General information	
Supplementary information	Observe the certificates, declarations of conformity, instruction manuals, and manuals where applicable. For information see www.pepperl-fuchs.com .

Configuration

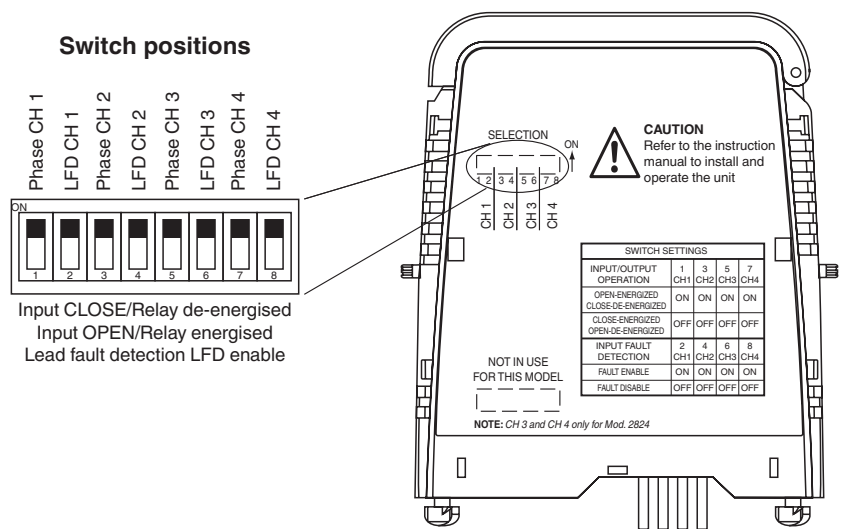

Channel 3 and 4 (switch 5 ... 8) only for HiD2824.

Configure the device in the following way:

- Push the red Quick Lok Bars on each side of the device in the upper position.
- Remove the device from Termination Board.
- Set the DIP switches according to the figure.

The pins for this device are trimmed to polarize it according to its safety parameter. Do not change! For further information see system description.

Release date 2018-05-08 08:13 Date of issue 2018-05-08 121451_eng.xml

Maximum switching power of output contacts

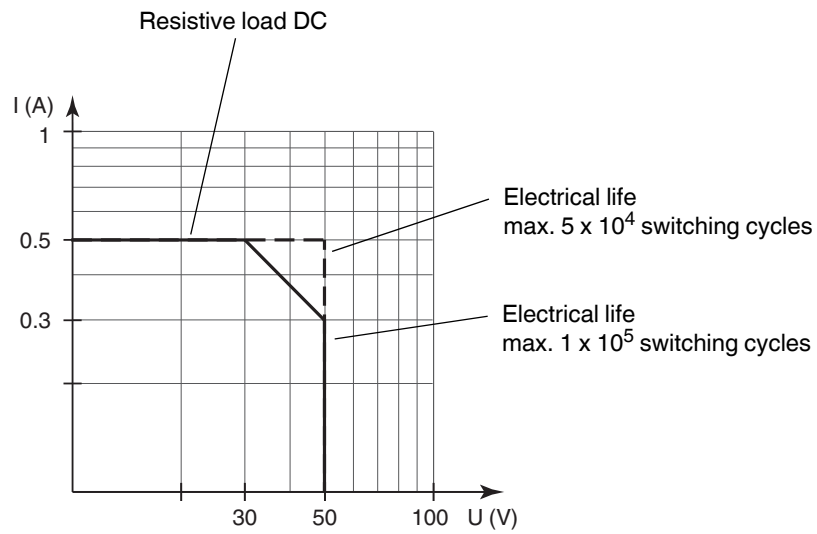

The maximum number of switching cycles is depending on the electrical load and may be higher when reduced currents and voltages are applied.