



Model number

VBM-CLX-DM
AS-Interface Scanner for ControlLogix PLC

Features

- Gateway compliant with AS-Interface specification 3.0
- 2 AS-Interface networks
- Commissioning, locally on the gateway or via AS-i Control Tools software
- Connects directly to ControlLogix backplane
- Hot Swappable
- Can be mounted in the local rack or in a remote EtherNet/IP or ControlNet rack

Accessories

K-ADP2 RPI

VAZ-SW-DIAGNOSTIC
Software for diagnostics, servicing, and final measurement of AS-Interface installations for all K20 and K30-type masters

Dimensions

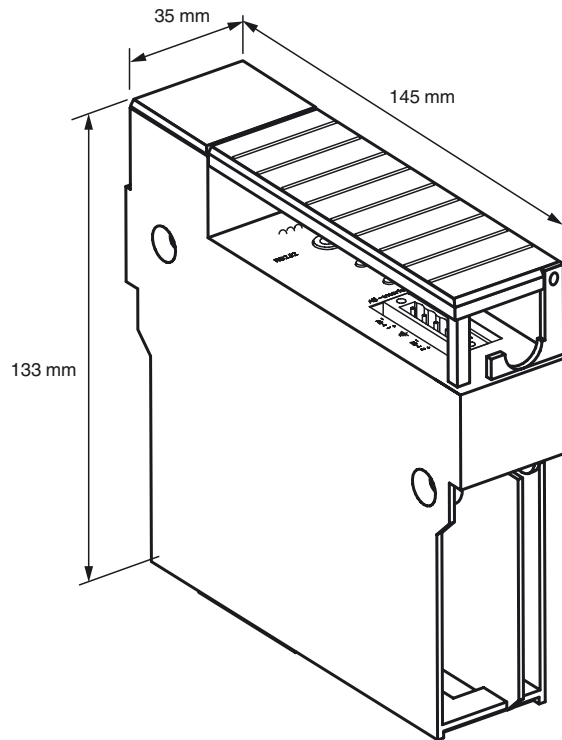

Electrical connection

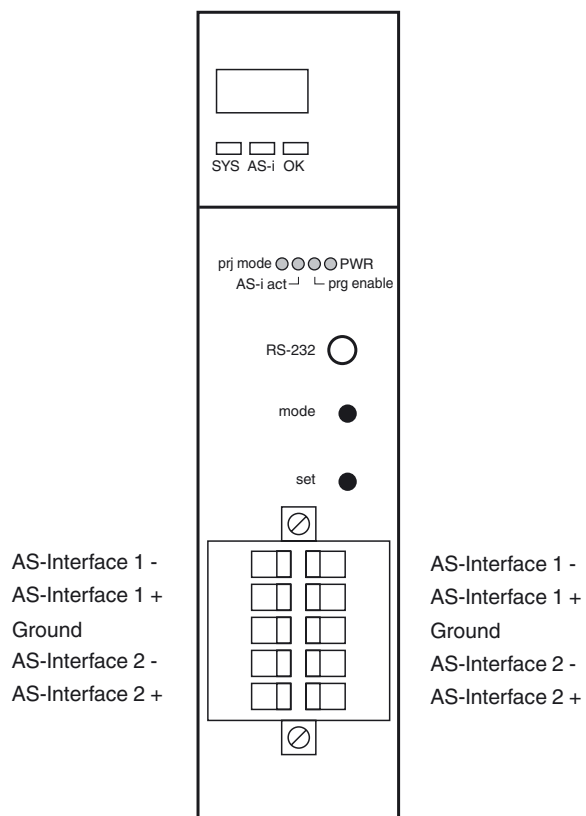

Release date: 2019-01-09 11:37 Date of issue: 2019-01-09 12:4961_Leng.xml

Technical data**General specifications**

AS-Interface specification	V3.0
PLC-Functionality	none
Description	AS-Interface Scanner for ControlLogix PLC

Functional safety related parameters

MTTF _d	115 a at 30 °C
-------------------	----------------

Indicators/operating means

Display	LC display
LED SYS	LED green: Power on
LED OK	LED green: AS-Interface network running normally; LED green flashing: Configuration mode; LED red flashing: Peripheral fault; LED red: Configuration error;
LED AS-i ACTIVE	LED green: AS-Interface running normally
LED PWR	LED green: Power on
LED PRJ MODE	project mode active; LED yellow
LED AS-i	LED green: AS-I network running normally; LED green flashing: Configuration mode; LED red flashing: Peripheral fault; LED red: Configuration error
Switch SET	Selection and setting of a slave address
Button MODE	Mode selection PRJ-operation/save configuration/cursor

Electrical specifications

Insulation voltage	U_i	≥ 500 V
Rated operating voltage	U_e	from backplane
Rated operating current	I_e	70 mA from Network 1 70 mA from Network 2 390 mA from 5.1 V DC, 2 mA from 24 V DC backplane

Interface

Protocol	ControlLogix, backplane
----------	-------------------------

Interface 2

Interface type	RS 232, serial
----------------	----------------

Connection

AS-Interface	double row terminals, removable
--------------	---------------------------------

Directive conformity

Electromagnetic compatibility	
Directive 2014/30/EU	EN 62026-2:2013

Standard conformity

Electromagnetic compatibility	EN 61000-6-2:2005, EN 61000-6-4:2001, EN 50295:1999
Degree of protection	EN 60529:2000
AS-Interface	EN 62026-2:2013

Ambient conditions

Ambient temperature	0 ... 55 °C (32 ... 131 °F)
Storage temperature	-25 ... 85 °C (-13 ... 185 °F)

Mechanical specifications

Degree of protection	IP20
Mass	375 g
Construction type	Mounting into backplane of ControlLogix PLC rack

Notes

DATA MAPPING – ControlLogix

The ControlLogix-Scanner works with all models.
 An example of an RS Logix 5000 screen capture for ControlLogix mapping (slot 1).

Tag Name	Value	Type	Description
ASi_Input	(...)	AB:1756_MODUL...	AS-i Input Data, Mailbox In
ASi_Output	(...)	AB:1756_MODUL...	AS-i Output Data, Mailbox Out
ASi_Output.Data	(...)	INT[50]	AS-i Output Data, Mailbox Out
ASi_Output.Data[0]	2048	INT	Circuit 1: Flags, Outputs AS-i Slaves 1..3
ASi_Output.Data[0].0	0	BOOL	C1: AS-i Slave 3, Bit 0
ASi_Output.Data[0].1	0	BOOL	C1: AS-i Slave 3, Bit 1
ASi_Output.Data[0].2	0	BOOL	C1: AS-i Slave 3, Bit 2
ASi_Output.Data[0].3	0	BOOL	C1: AS-i Slave 3, Bit 3
ASi_Output.Data[0].4	0	BOOL	C1: AS-i Slave 2, Bit 0
ASi_Output.Data[0].5	0	BOOL	C1: AS-i Slave 2, Bit 1
ASi_Output.Data[0].6	0	BOOL	C1: AS-i Slave 2, Bit 2
ASi_Output.Data[0].7	0	BOOL	C1: AS-i Slave 2, Bit 3
ASi_Output.Data[0].8	0	BOOL	C1: AS-i Slave 1, Bit 0
ASi_Output.Data[0].9	0	BOOL	C1: AS-i Slave 1, Bit 1
ASi_Output.Data[0].10	0	BOOL	C1: AS-i Slave 1, Bit 2
ASi_Output.Data[0].11	1	BOOL	C1: AS-i Slave 1, Bit 3
ASi_Output.Data[0].12	0	BOOL	C1: AS-i off-line
ASi_Output.Data[0].13	0	BOOL	C1: LOS-Master-Bit
ASi_Output.Data[0].14	0	BOOL	C1: switch to ConfigurationMode
ASi_Output.Data[0].15	0	BOOL	C1: switch to ProtectedMode