

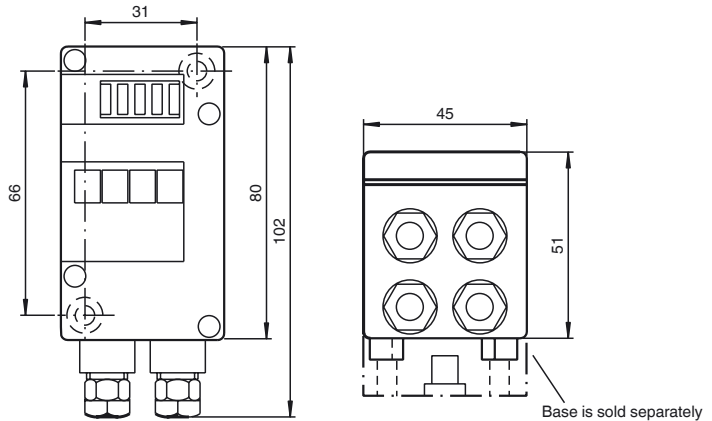

Dimensions



Electrical connection

Model number

VAA-4E-G4-ZE

G4 module IP67

4 inputs (PNP)

Features

- Degree of protection IP67
- Flat or round cable connection (via standardized EMS base, not included with delivery)
- Cable piercing method for flat cable
- Inputs for 2- and 3-wire sensors
- Power supply of inputs from the module
- Function display for bus and inputs
- LED indicator for overload on sensor supply

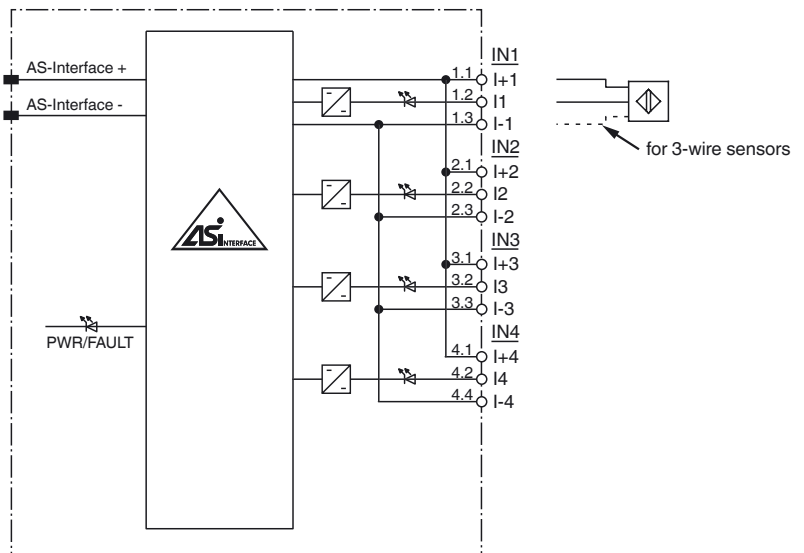

Indicating / Operating means

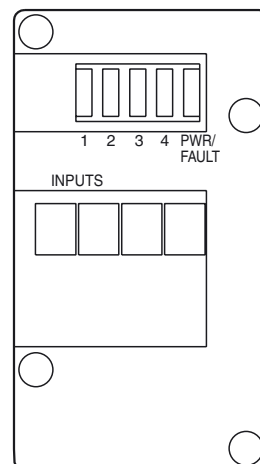

Release date: 2019-01-09 10:23 Date of issue: 2019-01-09 187946_eng.xml

Technical data**General specifications**

Slave type	Standard slave
AS-Interface specification	V3.0
Required master specification	≥ V2.0
UL File Number	E223772

Indicators/operating means

LED PWR/FAULT	dual LED green/red green: AS-Interface voltage red: communication error or address 0 green/red flashing: overload sensor supply
LED IN	switching state (input); 4 LED yellow

Electrical specifications

Rated operating voltage	U_e	26.5 ... 31.6 V from AS-Interface
Rated operating current	I_e	≤ 40 mA (without sensors) / max. 190 mA
Protection class		III
Surge protection		U_e : Over voltage category III, safe isolated power supplies (PELV)

Input

Number/Type	4 inputs for 2- or 3-wire sensors (PNP), DC
Supply	from AS-Interface
Voltage	21 ... 31 V
Current loading capacity	≤ 150 mA ($T_B \leq 40 \text{ °C}$), ≤ 120 mA ($T_B \leq 60 \text{ °C}$), short-circuit protected
Input current	≤ 8 mA (limited internally)
Switching point	according to DIN EN 61131-2 (Type 2)
0 (unattenuated)	≤ 2 mA
1 (attenuated)	≥ 4 mA

Directive conformity

Electromagnetic compatibility	
Directive 2014/30/EU	EN 62026-2:2013 EN 61000-6-2:2005 EN 61000-6-4:2007

Standard conformity

Degree of protection	EN 60529:2000
Fieldbus standard	EN 62026-2:2013
Input	EN 61131-2:2007
Emitted interference	EN 61000-6-4:2007
AS-Interface	EN 62026-2:2013
Noise immunity	EN 61000-6-2:2005

Programming instructions

Profile	S-0.0
IO code	0
ID code	0
ID1 code	F
ID2 code	E

Data bits (function via AS-Interface)	input	output
D0	IN1	-
D1	IN2	-
D2	IN3	-
D3	IN4	-

Parameter bits (programmable via AS-i)	function
P0	not used
P1	not used
P2	not used
P3	not used

Ambient conditions

Ambient temperature	-25 ... 60 °C (-13 ... 140 °F)
Storage temperature	-25 ... 85 °C (-13 ... 185 °F)
Relative humidity	85 % , noncondensing
Climatic conditions	For indoor use only
Altitude	≤ 2000 m above MSL
Pollution degree	3

Mechanical specifications

Degree of protection	IP67
Connection	cable piercing method or terminal compartment yellow flat cable or standard round cable inputs: M12 x 1.5 cable gland and cage tension spring terminals
Material	
Housing	PA 6 GF30
Mass	180 g
Tightening torque, housing screws	0.8 Nm
Mounting	DIN rail or screw mounting

Function

The VAA-4E-G4-ZE AS-Interface coupling module is a G4 module with 4 inputs. Mechanical contacts and 2- and 3-wire sensors can be connected to the inputs. The sensors are supplied via the module.

The IP67 rated G4 module is especially suitable for rough conditions. Sensors attach to cable glands and cage tension spring terminals thus making the installation especially user-friendly. For pre-addressing the module it can be plugged directly onto the adapter of the hand-held programming device VBP-HH1.

The current switching state of each channel is indicated by an LED, located on the module's top side.

Both flat and round cables can be used for the connection of the AS-Interface transmission line. Use the U-G1F base or the U-G1FF base for the AS-Interface flat cable. The AS-Interface cable is connected using the cable piercing method. The U-G1F base can also be used as IP67 AS-Interface distribution box. The U-G1FF base should be used, when modules with outputs are mounted in series with the module. The flat cable for external power supply can be placed in this base. The module does not access the supply line.

Use the U-G1P or the U-G1PP base for a round cable. These bases have the same functionality as the U-G1F or the U-G1FF bases.

Note:

An overloading of the sensor supply, e. g. short-circuit is signalled by a red/green flashing LED "PWR/FAULT" and reported to the AS-Interface master via the "Peripheral fault" function. Communication via the AS-Interface remains intact.

Accessories**VBP-HH1-V3.0-KIT**

AS-Interface Handheld with accessory

VBP-HH1-V3.0

AS-Interface Handheld

VAZ-G4-B1

Blind plug M12

Matching system components**U-G1F**

AS-Interface module mounting base for connection to flat cable (AS-Interface)

U-G1P

AS-Interface module mounting base for connection to round cable (AS-Interface)

Notes

Do not connect inputs and outputs, which are supplied via the module from AS-interface or via auxiliary power, with power supply and signal circuits with external potentials.

Release date: 2019-01-09 10:23 Date of issue: 2019-01-09 187946_eng.xml

Refer to "General Notes Relating to Pepperl+Fuchs Product Information".

Pepperl+Fuchs Group
www.pepperl-fuchs.com

USA: +1 330 486 0001
fa-info@us.pepperl-fuchs.com

Germany: +49 621 776 4411
fa-info@de.pepperl-fuchs.com

Singapore: +65 6779 9091
fa-info@sg.pepperl-fuchs.com