



Model number

VAR-G4F
AS-Interface Advanced Repeater

Features

- Minimum delay of signal
- Line lengthening by 100 m (max. 2 repeater in series)
- Galvanic isolation between AS-Interface circuits 1 and 2
- No parameterization
- Need no specific address on the AS-Interface bus
- Base for flat cable included in delivery

Dimensions

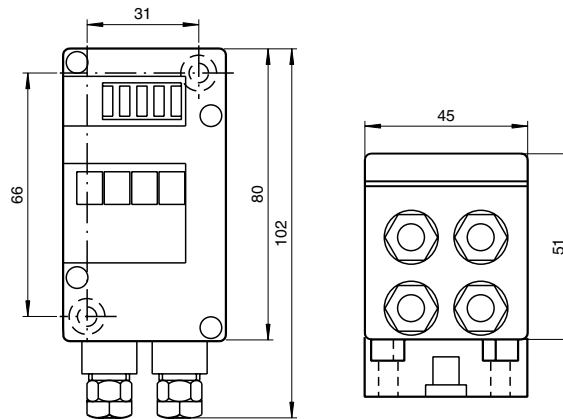

Electrical connection

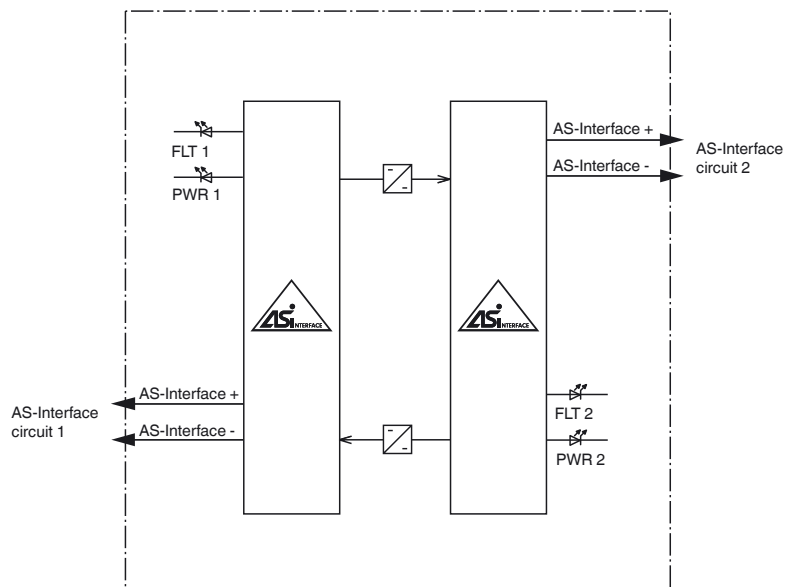

Indicating / Operating means

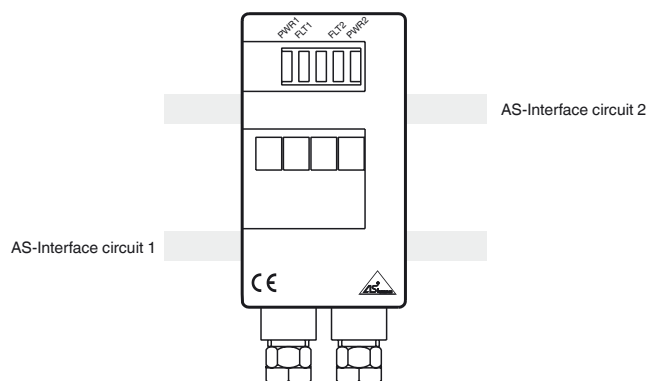

Release date: 2018-01-29 14:27 Date of issue: 2018-01-29 199561_Leng.xml

Refer to "General Notes Relating to Pepperl+Fuchs Product Information".

Pepperl+Fuchs Group
www.pepperl-fuchs.com

USA: +1 330 486 0001
fa-info@us.pepperl-fuchs.com

Germany: +49 621 776 4411
fa-info@de.pepperl-fuchs.com

Singapore: +65 6779 9091
fa-info@sg.pepperl-fuchs.com

Technical data**General specifications**

UL File Number	E223772
----------------	---------

Functional safety related parameters

MTTF _d	160 a at 30 °C
-------------------	----------------

Indicators/operating means

LED FLT	error display; LED red red: communication error
LED PWR	AS-Interface voltage; LED green

Electrical specifications

Rated operating voltage	U _e	26.5 ... 31.6 V from AS-Interface
Rated operating current	I _e	60 mA (per strand element), 120 mA (total)

Directive conformity

Electromagnetic compatibility	Directive 2014/30/EU	EN 62026-2:2013 EN 61000-6-2:2005 EN 61000-6-4:2001
-------------------------------	----------------------	---

Standard conformity

Degree of protection	EN 60529:2000
AS-Interface	EN 62026-2:2013

Ambient conditions

Ambient temperature	-10 ... 55 °C (14 ... 131 °F)
Storage temperature	-25 ... 75 °C (-13 ... 167 °F)

Mechanical specifications

Degree of protection	IP67
Connection	cable piercing method flat cable yellow
Material	
Housing	PA 6 GF30
Mounting	screw mounting

Notes

If connection of upper part with base U-G1PP: connect AS-Interface 2 + to terminal +, AS-Interface 2 - to terminal -, AS-Interface 1 + to terminal EXT+ and AS-Interface 1 - to terminal EXT-.

Function

The Advanced-Repeater VAR-G4F isolates two AS-Interface circuits galvanically from each other and processes the AS-Interface signals electrically, which extends the maximum line length by 100 m. Two Advanced-Repeaters can be connected in series resulting in a maximum line length of 300 m.

The Advanced-Repeater features an alignment between sender and receiver that has been optimized even further and offers a shorter delay when the signals pass through the Advanced-Repeater.

The Advanced-Repeater does not need any parameterization nor its own address on the AS-Interface; the total number of slaves (31 or 62) per line remains as it is.

A flat or round cable can be used for the connection to the AS-Interface transmission line. If the AS-Interface flat cable is to be used, the bottom part included in the scope of delivery is required. The contact to the two AS-Interface lines is made via the standardized EMS interface, i.e. by using the insulation penetration technique.

Due to the galvanic isolation, a power supply or power extender is required for each segment.

Two LEDs indicate the correct polarity of the AS-Interface lines, two LEDs signal communication faults in the respective AS-Interface circuits.

Accessories**VAZ-G4-B1**

Blind plug M12

Matching system components**U-G1PP**

AS-Interface module mounting base for connection to round cable (AS-Interface and external auxiliary power)