



Model Number

ML6-P-8m-RT/25/76a/115/136

Thru-beam sensor
with 2 m fixed cable

Features

- Precision sensor for standard applications
- Miniature design with very robust and versatile mounting options
- Short response time
- Rear mounting option for easy mounting without mounting bracket

Product information

The ML6 series is characterized by a robust, powerful and standard design in a miniature housing. The housing offers IP67/IP69K degree of protection, a food-grade lens, highly visible LEDs and robust all-metal bushings for mounting. Adjustable and tamper-proof sensors with a double push-pull output are available. The sensors have a high ambient light limit. Reflections from the background are suppressed. The unusually small, sharp light spot and the quick response time offer maximum switching precision on object edges. Clearly visible red light sources facilitates alignment. A high-performance fixed focus background suppressor is a useful feature. The sensors are suitable for precise object detection and open up a wide range of application fields.

Dimensions

Transmitter

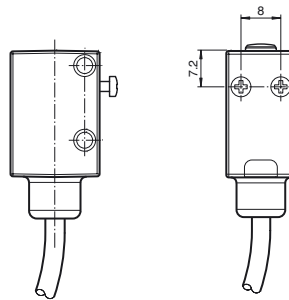

Receiver

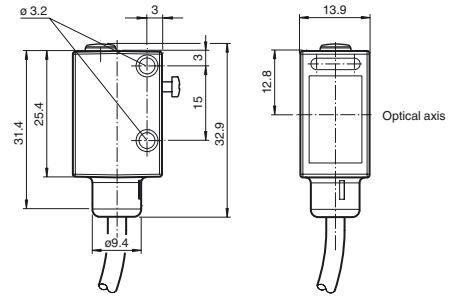

Electrical connection

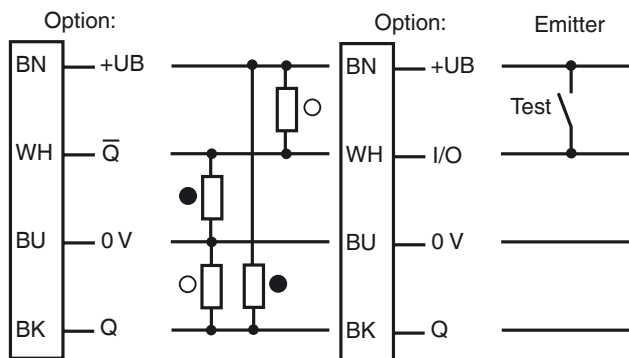

○ = Light on
● = Dark on

Indicators/operating means

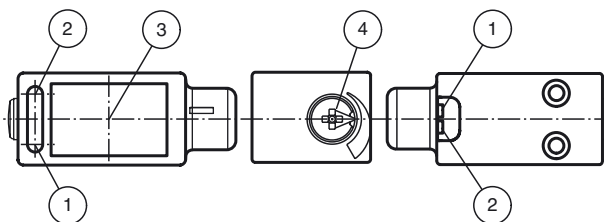

1	Operating display	green
2	Signal display (only Receiver)	yellow
3	Optical axis	
4	Sensitivity adjustment (only Receiver)	

Release date: 2013-04-18 11:32 Date of issue: 2013-05-13 236866_eng.xml

Technical data**System components**

Emitter	ML6-T-8m-RT/76a/115
Receiver	ML6-R/25/115/136

General specifications

Effective detection range	0 ... 8000 mm
Threshold detection range	10000 mm
Light source	LED
Light type	modulated visible red light
Target size	min. 7 mm
Diameter of the light spot	300 mm at 8000 mm detection range
Angle of divergence	approx. 2 °
Ambient light limit	
Continuous light	40000 Lux
Modulated light	5000 Lux

Functional safety related parameters

MTTF _d	550 a
Mission Time (T _M)	20 a
Diagnostic Coverage (DC)	60 %

Indicators/operating means

Operating display	LED green, statically lit Power on , Undervoltage indicator: Green LED, pulsing (approx. 0.8 Hz) , short-circuit : LED green flashing (approx. 4 Hz)
Function display	LED yellow, lights up with receiver lit flashes when falling short of the stability control
Controls	sensitivity adjustment

Electrical specifications

Operating voltage	U _B	10 ... 30 V DC
Ripple		< 10 %
No-load supply current	I ₀	< 15 mA at 24 V DC

Input

Test input	emitter deactivation at +U _B
------------	---

Output

Switching type	light/dark on, programmable	
Signal output	2 push-pull (4 in 1) outputs, complementary, short-circuit proof, reverse polarity protected	
Switching voltage	max. 30 V DC	
Switching current	max. 100 mA	
Voltage drop	U _d	≤ 2.5 V DC
Switching frequency	f	1 kHz
Response time		500 μs

Ambient conditions

Ambient temperature	-20 ... 60 °C (-4 ... 140 °F)
Storage temperature	-20 ... 75 °C (-4 ... 167 °F)

Mechanical specifications

Protection degree	IP67 / IP69K
Connection	2 m fixed cable
Material	
Housing	ABS
Optical face	PMMA
Cable	PUR
Mass	50 g (device)

Compliance with standards and directives

Standard conformity	
Product standard	EN 60947-5-2:2007 IEC 60947-5-2:2007
Shock and impact resistance	IEC / EN 60068. half-sine, 40 g in each X, Y and Z directions
Vibration resistance	IEC / EN 60068-2-6. Sinus. 10 -2000 Hz, 10 g in each X, Y and Z directions

Approvals and certificates

UL approval	cULus Listed
CCC approval	CCC approval / marking not required for products rated ≤36 V

Accessories**OMH-4.1**

Mounting Clamp

OMH-ML6

Mounting bracket

OMH-ML6-U

Mounting bracket

OMH-ML6-Z

Mounting bracket

OMH-11-02 Aperture-V-H 0.5 mm

Slit diaphragm can be affixed for detecting very small parts

OMH-11-04 Aperture-V-H 1.0 mm

Slit diaphragm can be affixed for detecting very small parts

OMH-11-06 Aperture-V-H 1.5 mm

Slit diaphragm can be affixed for detecting very small parts

OMH-11-08 Aperture-V-H 2.0 mm

Slit diaphragm can be affixed for detecting very small parts

Other suitable accessories can be found at www.pepperl-fuchs.com

Curves/Diagrams

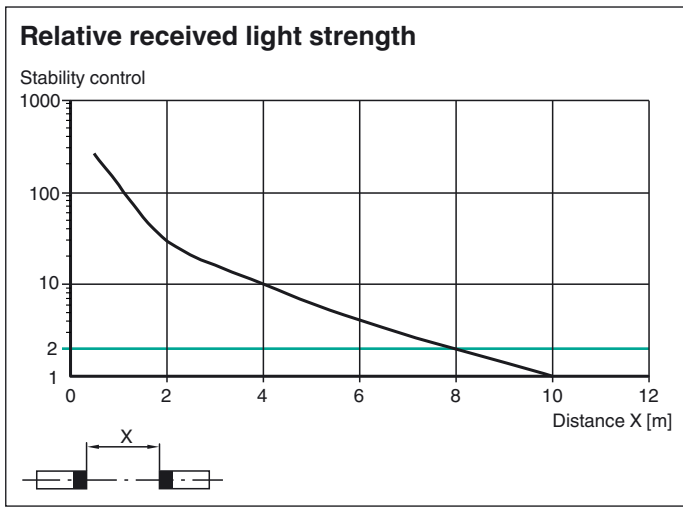
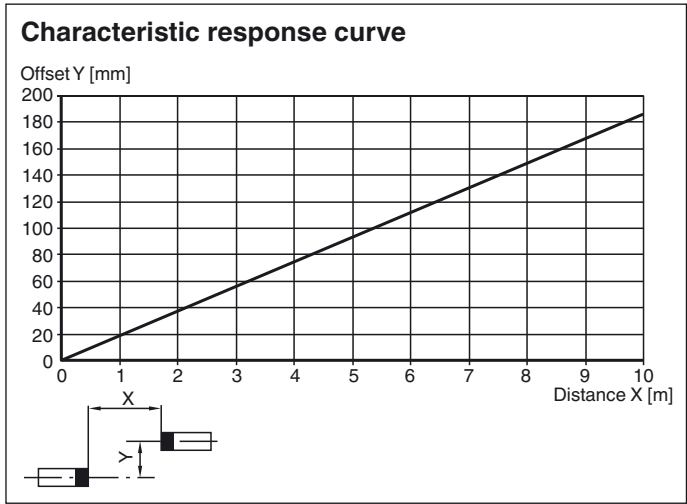

Curves/Diagrams

To aid in the detection of small objects, various apertures OMH-11-... can be placed on the sensors. This results in different detection ranges:

Aperture	Aperture type	Min. object size	Detection range
No aperture		7.0 mm	0 to 10 m
OMH-11-08	Vertical	2.0 mm	0 to 4 m
OMH-11-08	Horizontal	2.0 mm	0 to 2 m
OMH-11-06	Vertical	1.5 mm	0 to 3 m
OMH-11-06	Horizontal	1.5 mm	0 to 1.5 m
OMH-11-04	Vertical	1.0 mm	0 to 2 m
OMH-11-04	Horizontal	1.0 mm	0 to 1 m
OMH-11-02	Vertical	0.5 mm	0 to 1.5 m
OMH-11-02	Horizontal	0.5 mm	0 to 0.5 m

Release date: 2013-04-18 11:32 Date of issue: 2013-05-13 236866_eng.xml

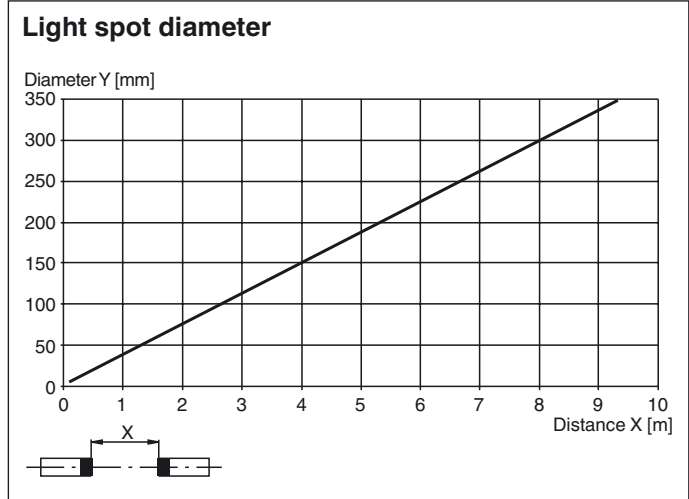

Aperture alignment

When attaching the aperture, make sure that the sensor lens is aligned exactly with the black aperture.

