

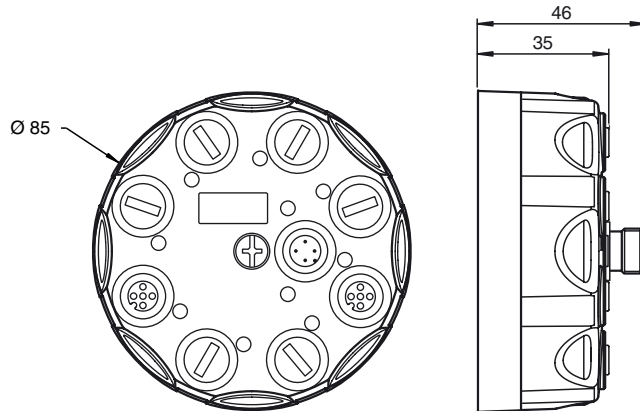

Dimensions

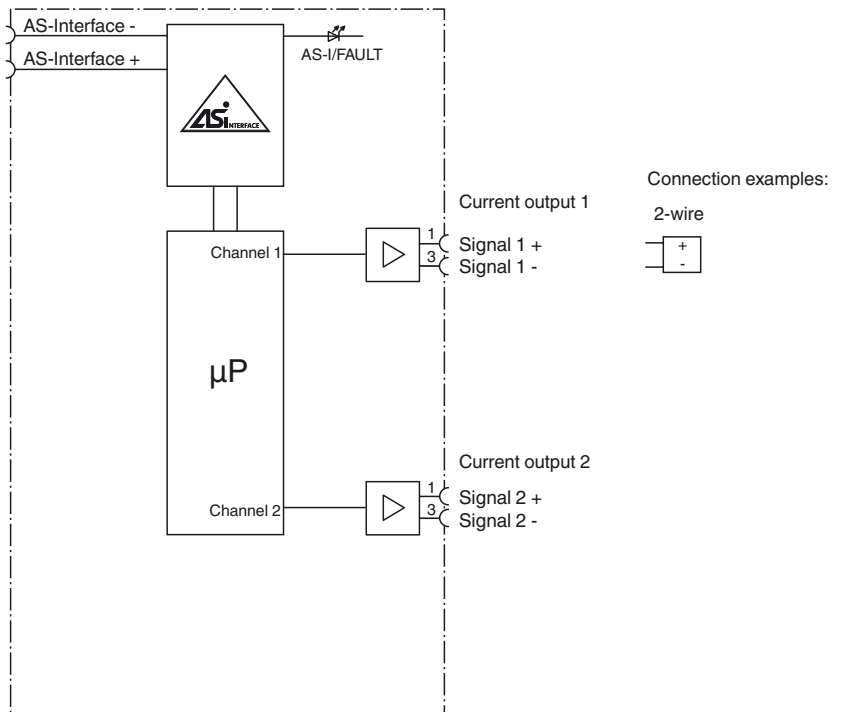

Electrical connection



Model number

VBA-2A-G11-I-V1

G11 analog module
2 analog outputs

Features

- Degree of protection IP68 / IP69K
- Function display for bus and outputs
- Accuracy $\pm 0.15\%$
- Integrated shielding
- Channel-specific output monitoring
- Communication monitoring

Indicating / Operating means

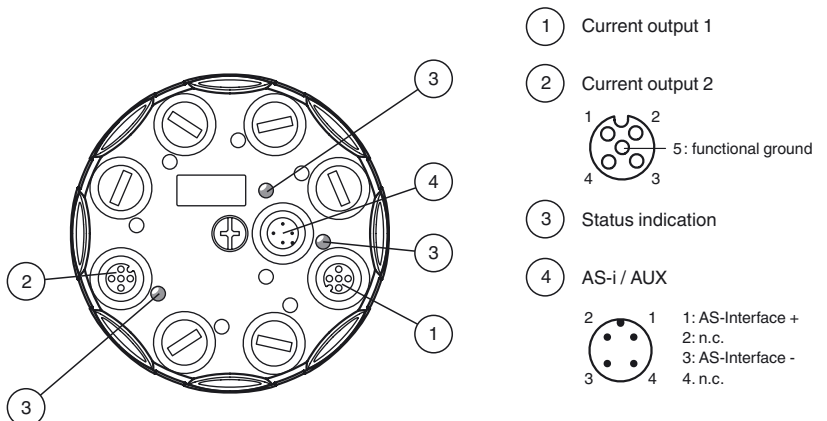

Release date: 2019-01-09 10:20 Date of issue: 2019-01-09 237499_eng.xml

Refer to "General Notes Relating to Pepperl+Fuchs Product Information".

Pepperl+Fuchs Group
www.pepperl-fuchs.com

USA: +1 330 486 0001
fa-info@us.pepperl-fuchs.com

Germany: +49 621 776 4411
fa-info@de.pepperl-fuchs.com

Singapore: +65 6779 9091
fa-info@sg.pepperl-fuchs.com

Technical data**General specifications**

Slave type	Standard slave
AS-Interface specification	V3.0
Required master specification	≥ V2.1
UL File Number	E223772

Functional safety related parameters

MTTF _d	370 a
Mission Time (T _M)	20 a
Diagnostic Coverage (DC)	0 %

Indicators/operating means

LED AS-i/FAULT	Status display; multi-colour LED Green: normal operation Red: communication fault Flashing yellow/red: address 0 Flashing green/red: peripheral fault
LED ANALOG	Status of output signal; yellow LED Yellow: 0 mA ≤ I ≤ 23 mA Yellow flashing: lead breakage or I > 23 mA

Electrical specifications

Rated operating voltage	U _e	26.5 ... 31.6 V from AS-Interface
Rated operating current	I _e	≤ 100 mA
Protection class		III
Surge protection		U _e : Over voltage category III, safe isolated power supplies (PELV)

Output

Number/Type	2 analog outputs (current), 0 ... 20 mA
Supply	from AS-Interface
Load	≤ 600 Ω
Resolution	6 μA
Accuracy	0.15 % of full-scale value
Temperature influence	1 μA/K

Directive conformity

Electromagnetic compatibility	
Directive 2014/30/EU	EN 62026-2:2013

Standard conformity

Degree of protection	EN 60529:2000
Fieldbus standard	EN 62026-2:2013
Emitted interference	EN 61000-6-4:2007
AS-Interface	EN 62026-2:2013
Noise immunity	EN 61000-6-2:2005, EN 61326-1:2006, IEC 62026-2:2008

Programming instructions

Profile	S-7.3.5
IO code	7
ID code	3
ID1 code	F
ID2 code	5
Data bits (function via AS-Interface)	The transfer of the data value is based on AS-Interface Profile 7.3.

Parameter bits (programmable via AS-i)

P0	function Watchdog: P0=1 (default), watchdog active P0=0, watchdog inactive
P1	not used
P2	Indication of peripheral fault: P2=1 (default), peripheral fault is reported P2=0, peripheral fault is not reported
P3	not used

Ambient conditions

Ambient temperature	-25 ... 70 °C (-13 ... 158 °F)
Storage temperature	-25 ... 85 °C (-13 ... 185 °F)
Relative humidity	85 % , noncondensing
Climatic conditions	For indoor use only
Altitude	≤ 2000 m above MSL
Pollution degree	3

Mechanical specifications

Degree of protection	IP68 / IP69K
Connection	AS-Interface: M12 round connector Outputs: M12 round connector
Material	
Housing	PBT PC
Mounting screw	Stainless steel 1.4305 / AISI 303
Mass	200 g
Tightening torque, housing screws	1.8 Nm
Tightening torque, cable gland	0.4 Nm
Mounting	Mounting plate

Function

The analog module VBA-2A-G11-I-V1 has two analog current outputs (0 mA ... 20 mA). Power is supplied to the outputs through the yellow AS-Interface cable. Analog value conversion and data transfer are provided asynchronously according to AS-Interface profile 7.3. The rise time of the analog signals is approx. 2 ms.

If the analog value "0" is returned, lead breakages are not monitored on the respective channel. Peripheral faults are not signaled when there is no active connection to an actuator. If the internal "watchdog" monitoring function is enabled, the output signals are reset to zero if communication with the AS-Interface fails.

The G11 module with IP68/IP69K protection is particularly suitable for demanding field applications. The connection to the actuators is established via M12 connectors. The module can be preaddressed by connecting it to the handheld programming unit VBP-HH1. The connection to the AS-Interface transfer line is established via an M12 connector.

Note:

A lead breakage or an output value outside the value range is also transmitted to the AS-Interface master via the 'peripheral fault' function. Communication via the AS-Interface continues.

Accessories**VAZ-V1-B3**

Blind plug for M12 sockets

VBP-HH1-V3.0-KIT

AS-Interface Handheld with accessory

Notes

Do not connect inputs and outputs, which are supplied via the module from AS-interface or via auxiliary power, with power supply and signal circuits with external potentials.

Mounting instructions

Screw the device onto a level mounting surface using two M4 attachment screws. The functional earth of the M12 round connectors is connected with the metal insert in the base via the tightened central screw. This metal insert can be connected to functional earth via the mounting screws to improve the EMC. The mounting screws are not included.

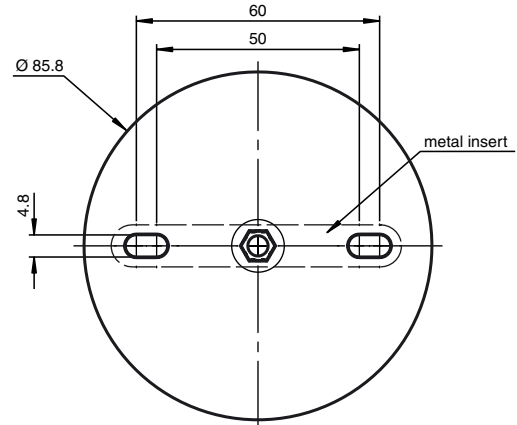

Screw a blind plug onto spare connections to ensure the protection category.