

Features

- 4-channel
- Inputs with plug-in Ex e terminals
- Installation in suitable enclosures in Zone 1
- Module can be exchanged under voltage (hot swap)
- Power supply for 2-wire transmitters with 4 mA ... 20 mA
- Supply circuit 15 V (20 mA)
- Input from active signals of 4-wire transmitters
- HART communication via field bus or service bus
- Simulation mode for service operations (forcing)
- Line fault detection (LFD)
- Permanently self-monitoring

Function

The transmitter power supply feeds 2-wire transmitters. Active signals from separately powered field devices and 4-wire transmitters can be connected. Open and short-circuit line faults are detected. The device is supplied with plug-in Ex e terminals and protective cover. The input is galvanically isolated from the bus and the power supply.

Assembly

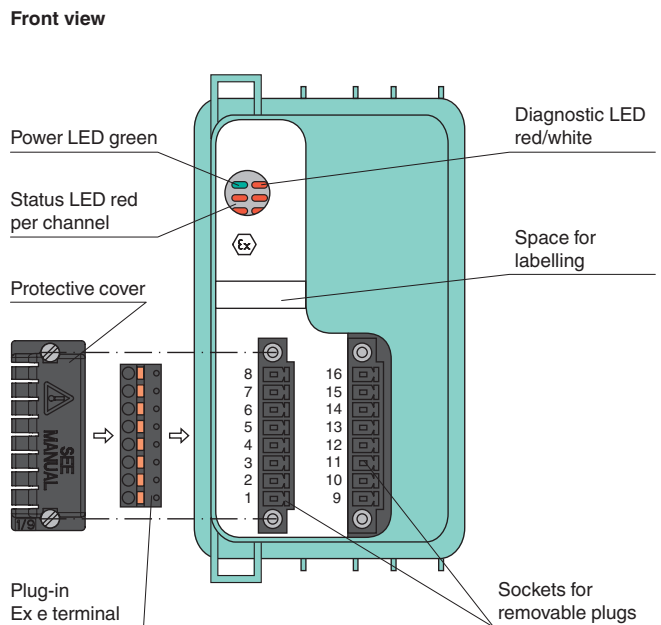

Connection

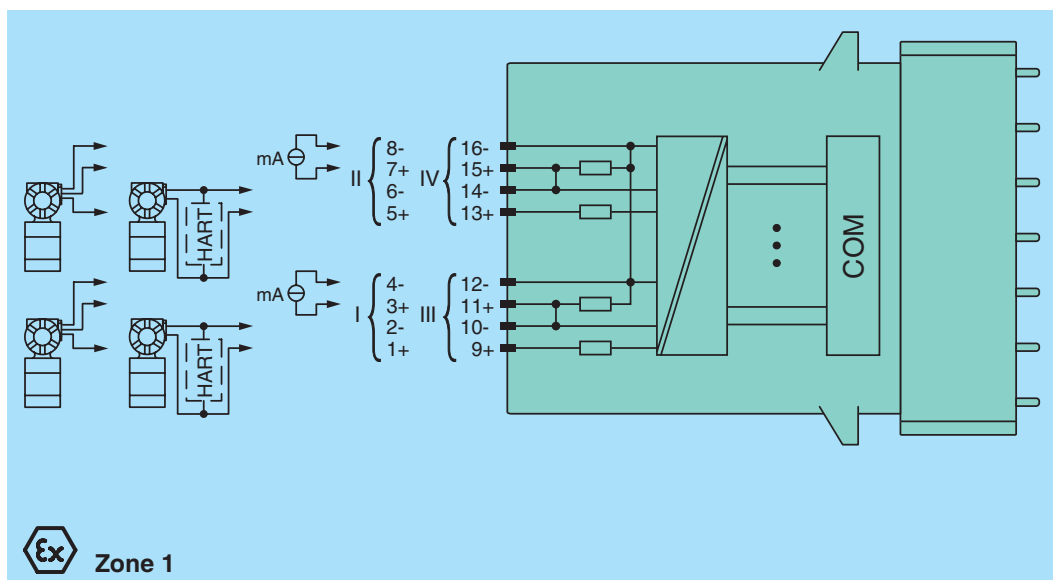

Release date 2018-09-14 09:48 Date of issue 2018-09-14 238487_eng.xml

Refer to "General Notes Relating to Pepperl+Fuchs Product Information".

Pepperl+Fuchs Group
www.pepperl-fuchs.com

USA: +1 330 486 0002
pa-info@us.pepperl-fuchs.com

Germany: +49 621 776 2222
pa-info@de.pepperl-fuchs.com

Singapore: +65 6779 9091
pa-info@sg.pepperl-fuchs.com

Slots	
Occupied slots	2
Supply	
Connection	backplane bus
Rated voltage	U_r 12 V DC , only in connection with the power supplies FB92**
Power dissipation	1.5 W
Power consumption	2.7 W
Internal bus	
Connection	backplane bus
Interface	manufacturer-specific bus to standard com unit
Analog input	
Number of channels	4
Suitable field devices	
Field device	pressure converter
Field device [2]	flow converter
Field device [3]	level converter
Field device [4]	Temperature Converter
Field device interface	
Connection	2-wire transmitter
Connection [2]	3-wire transmitter
Connection [3]	4-wire transmitter
Connection	2-wire transmitter (HART): Supply circuit: channel I 1+, 2-, channel II 5+, 6-, channel III 9+, 10-, channel IV 13+, 14- 3-wire transmitter: Supply circuit: channel I 1+, 4-, channel II 5+, 8-, channel III 9+, 12-, channel IV 13+, 16- Measurement loop: channel I 3+, 4-, channel II 7+, 8-, channel III 11+, 12-, channel IV 15+, 16- 4-wire transmitter (powered externally): Measurement loop: channel I 3+, 4-, channel II 7+, 8-, channel III 11+, 12-, channel IV 15+, 16-
Transmitter supply voltage	≥ 15 V at 20 mA ; 21.5 V at 4 mA
Input resistance	15 Ω
Conversion time	≤ 100 ms
Line fault detection	can be switched on/off for each channel via configuration tool , configurable via configuration tool
Short-circuit	factory setting: > 22 mA configurable between 0 ... 26 mA
Open-circuit	factory setting: < 1 mA configurable between 0 ... 26 mA
HART communication	yes
HART secondary variable	no
Transfer characteristics	
Deviation	
After calibration	0.1 % of the signal range at 20 °C (68 °F)
Influence of ambient temperature	0.1 %/10 K of the signal range
Resolution	12 Bit (0 ... 26 mA)
Refresh time	100 ms
Indicators/settings	
LED indication	Power LED (P) green: supply Diagnostic LED (I) red: module fault , red flashing: communication error , white: fixed parameter set (parameters from com unit are ignored) , white flashing: requests parameters from com unit Status LED (1-4) red: line fault (lead breakage or short circuit)
Coding	optional mechanical coding via front socket
Directive conformity	
Electromagnetic compatibility	
Directive 2014/30/EU	EN 61326-1:2006
Conformity	
Electromagnetic compatibility	
Degree of protection	IEC 60529:2000
Environmental test	EN 60068-2-14:2009
Shock resistance	EN 60068-2-27:2009
Vibration resistance	EN 60068-2-6:2008
Damaging gas	EN 60068-2-42:2003
Relative humidity	EN 60068-2-78:2001
Ambient conditions	
Ambient temperature	-20 ... 60 °C (-4 ... 140 °F)
Storage temperature	-25 ... 85 °C (-13 ... 185 °F)
Relative humidity	95 % non-condensing
Shock resistance	shock type I, shock duration 11 ms, shock amplitude 15 g, number of shocks 18

Release date 2018-09-14 09:48 Date of issue 2018-09-14 238487_eng.xml

Refer to "General Notes Relating to Pepperl+Fuchs Product Information".

Vibration resistance	frequency range 10 ... 150 Hz; transition frequency: 57.56 Hz, amplitude/acceleration ± 0.075 mm/1 g; 10 cycles frequency range 5 ... 100 Hz; transition frequency: 13.2 Hz amplitude/acceleration ± 1 mm/0.7 g; 90 minutes at each resonance
Damaging gas	designed for operation in environmental conditions acc. to ISA-S71.04-1985, severity level G3
Mechanical specifications	
Degree of protection	IP20 (module) , a separate housing is required acc. to the system description
Connection	Ex e spring terminal with protective cover
Mass	approx. 750 g
Dimensions	57 x 107 x 132 mm (2.2 x 4.2 x 5.2 inch)
Data for application in connection with hazardous areas	
EU-Type Examination Certificate	BVS 11 ATEX E 093 X
Marking	 II 2 G Ex db eb IIC T4
Galvanic isolation	
Input/power supply, internal bus	safe electrical isolation acc. to EN 60079-11:2007 , voltage peak value 375 V
Directive conformity	
Directive 2014/34/EU	EN 60079-0:2009 EN 60079-1:2007 EN 60079-7:2007
International approvals	
ATEX approval	BVS 11 ATEX E 093X
INMETRO	Brazil: TÜV 14.1599X
EAC approval	Russia: RU C-IT.MIII06.B.00129
Marine approval	
Lloyd Register	15/20021
American Bureau of Shipping	T1450280/UN
Bureau Veritas Marine	22449/B0 BV
General information	
System information	The module has to be mounted in appropriate backplanes (FB92**) in Zone 1, 2, or outside hazardous areas. Observe the corresponding EC-type examination certificate.
Supplementary information	EC-Type Examination Certificate, Statement of Conformity, Declaration of Conformity, Attestation of Conformity and instructions have to be observed where applicable. For information see www.pepperl-fuchs.com .

Release date 2018-09-14 09:48 Date of issue 2018-09-14 238487_eng.xml