



Model Number

PCV80I-F200-R4-V19

Read head for incident light positioning system

Features

- **RS 485 interface**
- **Non-contact positioning on Data Matrix code tape**
- **Travel ranges up to 10 km, in X and Y direction**
- **Mechanically rugged: no wearing parts, long operating life, maintenance-free**
- **High resolution and precise positioning, especially for facilities with curves and switch points as well as inclines and declines.**
- **Infrared light**

Diagrams

Coordinates

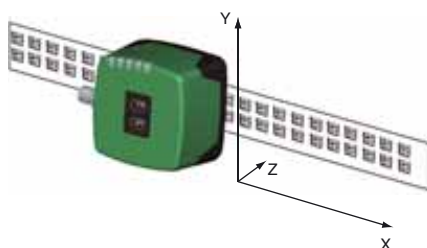

Release date: 2017-03-24 11:38 Date of issue: 2017-03-24 242704_eng.xml

Technical data

General specifications

Passage speed v	≤ 12.5 m/s
Measuring range	max. 10000 m
Light type	Integrated LED lightning , infrared
Read distance	80 mm
Depth of focus	± 15 mm
Reading field	40 mm x 25 mm
Ambient light limit	100000 Lux
Resolution	± 0.1 mm

Nominal ratings

Camera	
Type	CMOS , Global shutter
Processor	
Clock pulse frequency	600 MHz
Speed of computation	4800 MIPS

Functional safety related parameters

MTTF _d	96 a
Mission Time (T _M)	48 a
Diagnostic Coverage (DC)	0 %

Indicators/operating means

LED indicator	7 LEDs (communication, alignment aid, status information)
---------------	---

Electrical specifications

Operating voltage U_B	15 ... 30 V DC , PELV
No-load supply current I_0	max. 200 mA
Power consumption P_0	3 W

Interface

Interface type	RS 485 interface
Data output code	binary code
Transfer rate	38400 ... 230400 Bit/s
Termination	Switchable terminal resistor
Query cycle time	≥ 10 ms

Input

Input type	1 to 3 functional inputs , programmable
------------	---

Output

Output type	1 to 3 switch outputs , PNP , programmable , short-circuit protected
Switching voltage	Operating voltage
Switching current	150 mA each output

Standard conformity

Emitted interference	EN 61000-6-4:2007+A1:2011
Noise immunity	EN 61000-6-2:2005
Shock resistance	EN 60068-2-27:2009
Vibration resistance	EN 60068-2-6:2008

Ambient conditions

Operating temperature	0 ... 60 °C (32 ... 140 °F) , -20 ... 60 °C (-4 ... 140 °F) (noncondensing; prevent icing on the lens!)
Storage temperature	-20 ... 85 °C (-4 ... 185 °F)
Relative humidity	90 % , noncondensing

Mechanical specifications

Connection type	8-pin, M12 x 1 connector
Housing width	70 mm
Housing height	70 mm
Degree of protection	IP67
Material	
Housing	PC/ABS
Mass	approx. 160 g

Approvals and certificates

UL approval	cULus Listed, General Purpose, Class 2 Power Source, Type 1 enclosure
CCC approval	CCC approval / marking not required for products rated ≤ 36 V

Dimensions

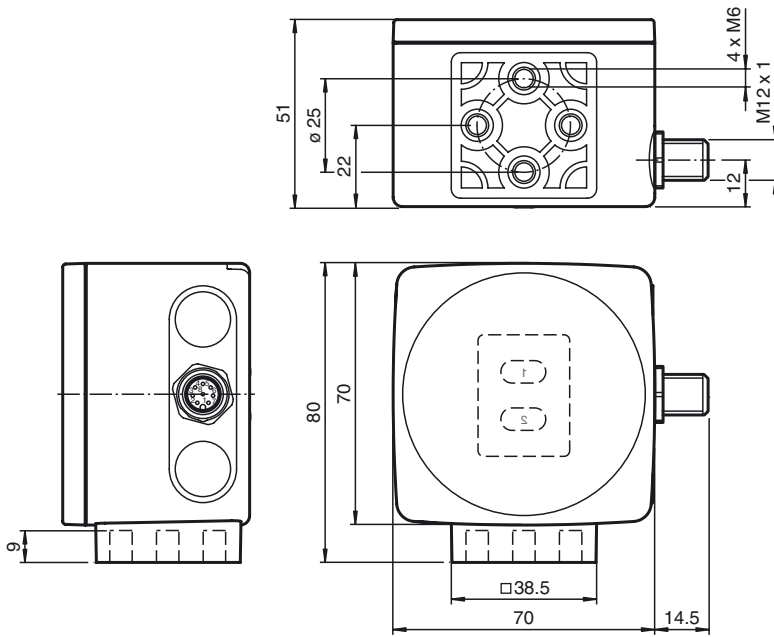

Additional Information

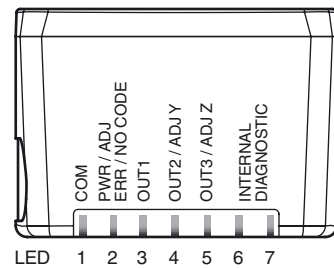
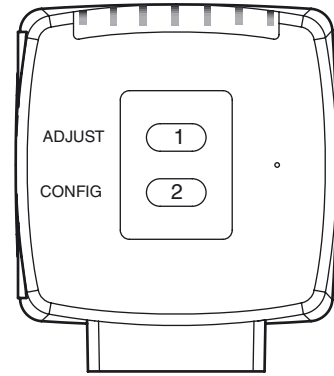

Electrical Connection

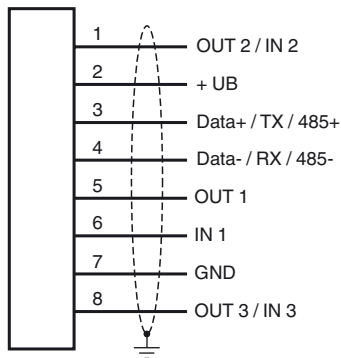

Pinout

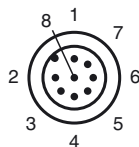

General

The reading head is part of the positioning system in the method for measurement by Pepperl+Fuchs. It consists of a camera module and an integrated illumination unit among other things. The reading head detects position marks, which are put on an adhesive code band in the form of Data Matrix code. The mounting of the code band is as a rule stationary on a firm part of the plant (elevator shaft, overhead conveyor mounting rails...); that of the reading head is parallel on the moving "vehicle" (elevator car, overhead conveyor chassis...).

Accessories

PCV-USB-RS485-Converter Set
USB to RS 485 interface converter

PCV-KBL-V19-STR-RS485
Cable unit with power supply for USB / RS-485 interface converter

V19-G-ABG-PG9
Female connector, M12, 8-pin, shielded, field attachable

V19-G-ABG-PG9-FE
Female connector, M12, 8-pin, shielded, field attachable

PCV-SC12
Grounding clip for PCV system

PCV-LM25
Marker head for 25 mm code tape

PCV-MB1
Mounting bracket for PCV* read head

PCV-AG80
Alignment guide for PCV80-* read head

Vision Configurator
Operating software for camera-based sensors

Release date: 2017-03-24 11:38 Date of issue: 2017-03-24 242704_eng.xml

Mounting and commissioning

Mount the reading head such that its optical surface captures the optimal read distance to the code band (see Technical Data). The stability of the mounting and the guidance of the vehicle must be provided such that the depth of field of the reading head is not closed during operation. All reading heads can be optimally customized by parameterization for specific requirements. The parameterization of reading heads with a bi-directional interface (all except SSI-interface) can take place via the interface itself (internal parameterization) or via an optical parameterization code (external parameterization). The reading heads with SSI interface only have the possibility of external parameterization via optical parameterization codes.

Displays and Controls

The reading head allows visual function check and fast diagnosis with 7 indicator LEDs. The reading head has 2 buttons on the reverse of the device to activate the alignment aid and parameterization mode.

LEDs

LED	Color	Label	Meaning
1	Yellow	COM	Communication active
2	Green/red	PWR/ADJ ERR/NO CODE	Code recognized/not recognized, Error
3	Yellow	OUT1	Output 1
4	Yellow	OUT2/ADJ Y	Output 2, Alignment aid Y
5	Yellow	OUT3/ADJ Z	Output 3, Alignment aid Z
6,7	red/green/yellow	INTERNAL DIAGNOSTICS	Internal diagnostics

External parameterization

For external parameterization you require the parameterization code as Data Matrix with the desired reading head parameters. Data Matrix code cards for step-by-step external parameterization are printed in the reading heads operating instructions.

Parameterization is only possible within 10 minutes of switching on the reading head. If a button is pressed after 10 minutes subsequent to switching on, there is visual signaling via the LEDs (LED1, yellow/LED2, red/LED3, yellow/LED4, yellow/LED5, yellow flash for 2 seconds)

- The switchover from normal operation to parameterization mode is via button 2 on the reverse of the reading head. Button 2 must be pressed for more than 2 seconds. LED3 now flashes.

Note: Parameterization mode automatically ends after 1 minute of inactivity. The reading head returns to normal operation and works with unchanged settings.

- Place the parameterization code in the view of the camera module. After recognition of the parameterization code, the green LED2 lights up for 1s. In the event of an invalid parameterization code, the red LED2 lights up for 2 s.
- A short press on button 2 ends the parameterization mode and the changed parameters are not stored volatile in the reading head.

Alignment aid for the Y and Z coordinates

The activation of the alignment aid is only possible within 10 minutes of switching on the reading head. The switchover from normal operation to "alignment aid operating mode is via button 1 on the reverse of the reading head.

- Press the button 1 for longer than 2 s. LED2 flashes green for a recognized code band. LED2 flashes red for an unrecognized code band.
- Z coordinate:** If the distance of the camera to the code band too small, the yellow LED5 lights up. If the distance of the camera to the code band too large, the yellow LED5 lights up. Within the target range, the yellow LED5 flashes at the same time as the green LED2.
- Y coordinate:** If the optical axis of the camera is too deep in relation to the middle of the code band, the yellow LED4 lights up. If the optical axis is too high, the yellow LED4 extinguishes. Within the target range, the yellow LED4 flashes at the same time as the green LED2.
- A short press on button 1 ends the alignment aid and the reading head changes to normal operation.