



Model number

PCV80-F200-B16-V15

Read head for incident light positioning system

Features

- Non-contact positioning on Data Matrix code tape
- Mechanically rugged: no wearing parts, long operating life, maintenance-free
- High resolution and precise positioning, especially for facilities with curves and switch points as well as inclines and declines.
- Travel ranges up to 10 km, in X and Y direction
- CANopen interface

Diagramms

Coordinates

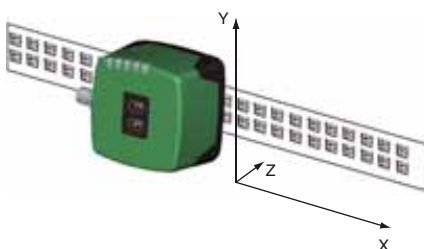

System components

PCV-CM20-***

Event Marker for PCV system

PCV*-CA10-* / PCV*-CA20-*

Data Matrix code tape

Technical data

General specifications

Passage speed v	≤ 12.5 m/s
Measuring range	max. 10000 m
Light type	Integrated LED lightning (red)
Read distance	80 mm
Depth of focus	± 15 mm
Reading field	40 mm x 25 mm
Ambient light limit	100000 Lux
Resolution	± 0.1 mm

Nominal ratings

Camera	
Type	CMOS , Global shutter
Processor	
Clock pulse frequency	600 MHz
Speed of computation	4800 MIPS

Functional safety related parameters

MTTF _d	103 a
Mission Time (T _M)	51 a
Diagnostic Coverage (DC)	0 %

Indicators/operating means

LED indicator	7 LEDs (communication, alignment aid, status information)
---------------	---

Electrical specifications

Operating voltage U _B	15 ... 30 V DC , PELV
No-load supply current I ₀	max. 400 mA
Power consumption P ₀	6 W

Interface

Interface type	CANopen , galvanically isolated
Data output code	binary code
Transfer rate	max. 1 MBit/s

Interface 2

Interface type	USB Service
----------------	-------------

Input

Input type	1 function input 0-level: -U _B or unwired 1-level: +8 V ... +U _B , programmable
Input impedance	≥ 27 kΩ

Output

Output type	1 to 3 switch outputs , programmable , short-circuit protected
Switching voltage	Operating voltage
Switching current	150 mA each output

Standard conformity

Emitted interference	EN 61000-6-4:2007+A1:2011
Noise immunity	EN 61000-6-2:2005
Shock resistance	EN 60068-2-27:2009
Vibration resistance	EN 60068-2-6:2008

Ambient conditions

Operating temperature	0 ... 60 °C (32 ... 140 °F) , -20 ... 60 °C (-4 ... 140 °F) (noncondensing; prevent icing on the lens!)
Storage temperature	-20 ... 85 °C (-4 ... 185 °F)
Relative humidity	90 % , noncondensing

Mechanical specifications

Connection type	8-pin, M12x1 connector, standard (supply+IO) 5-pin, M12x1 socket, A-coded (bus out/termination) 5-pin, M12x1 connector, A-coded (bus in)
Housing width	70 mm
Housing height	70 mm
Housing depth	50 mm
Degree of protection	IP67
Material	
Housing	PC/ABS
Mass	approx. 200 g

Approvals and certificates

UL approval	cULus Listed, General Purpose, Class 2 Power Source, Type 1 enclosure
CCC approval	CCC approval / marking not required for products rated ≤36 V

Dimensions

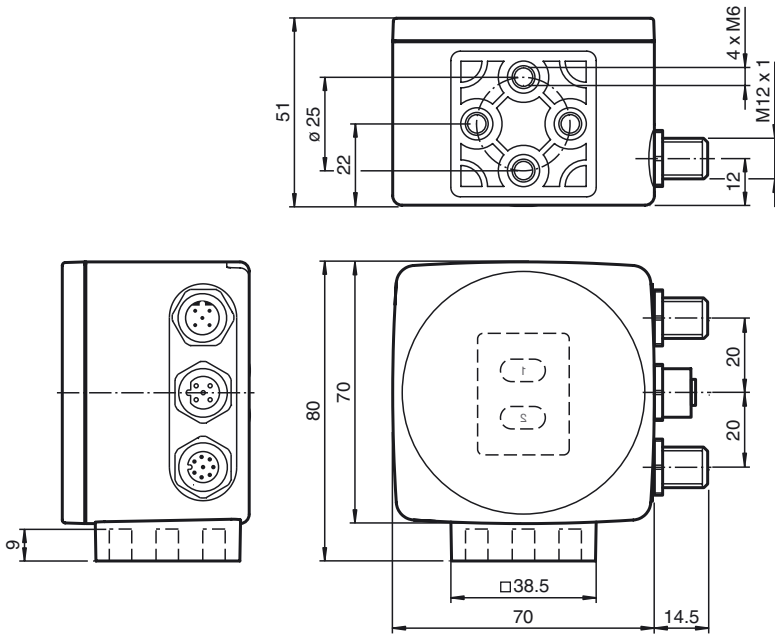

Electrical connection

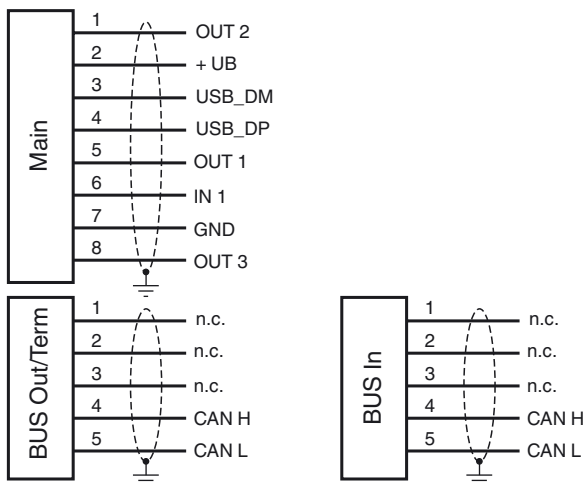

Pinout

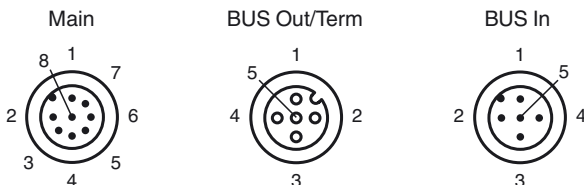

General

The PCV... reading head is part of the positioning system in the method for measurement by Pepperl+Fuchs. It consists of a camera module and an integrated illumination unit among other things. The reading head detects position marks, which are put on an adhesive code band in the form of Data Matrix code. The mounting of the code band is as a rule stationary on a firm part of the plant (elevator shaft, overhead conveyor mounting rails...); that of the reading head is parallel on the moving "vehicle" (elevator car, overhead conveyor chassis...).

Mounting and commissioning

Mount the reading head such that its optical surface captures the optimal read distance to the

System components

PCV-CR40

Coded repair tape for PCV system

PCV-CR20

Coded repair tape for PCV system

PCV6M-CA20-0

Data Matrix code tape

PCV10M-CA20-0

Data Matrix code tape

PCV20M-CA20-0

Data Matrix code tape

PCV50M-CA20-0

Data Matrix code tape

PCV100M-CA20-0

Data Matrix code tape

VAZ-V1S-B

Blind plug for M12 sockets

Additional information

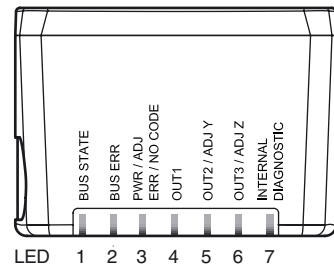
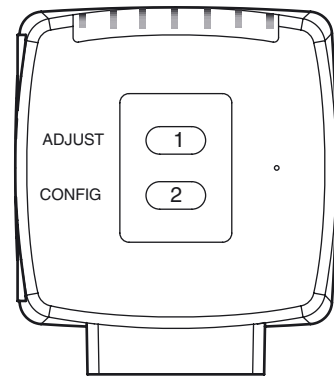

Accessories

PCV-SC12

Grounding clip for PCV system

ICZ-TR-CAN/DN-V15

Terminal resistor for DeviceNet, CANopen

PCV-LM25

Marker head for 25 mm code tape

PCV-MB1

Mounting bracket for PCV* read head

PCV-AG80

Alignment guide for PCV80-* read head

PCV-SC12A

Grounding clip for PCV system

Release date: 2018-07-26 15:45 Date of issue: 2018-07-26 251411_eng.xml

Accessories

V19-G-2M-PUR-ABG

Female cordset, M12, 8-pin, shielded, PUR cable

V19-G-10M-PUR-ABG

Female cordset, M12, 8-pin, shielded, PUR cable

V19-G-5M-PUR-ABG

Female cordset, M12, 8-pin, shielded, PUR cable

V15-G-2M-PUR-CAN

DeviceNet/CANOpen bus cable, M12, PUR cable, 5-pin

V15-G-2M-PUR-CAN-V15-G

DeviceNet/CANOpen bus cable, M12 to M12, PUR cable 5-pin

V15-G-5M-PUR-CAN-V15-G

DeviceNet/CANOpen bus cable, M12 to M12, PUR cable 5-pin

Vision Configurator

Operating software for camera-based sensors

PCV-KBL-V19-STR-USB

USB cable unit with power supply

code band (see Technical Data). The stability of the mounting and the guidance of the vehicle must be provided such that the depth of field of the reading head is not closed during operation. All reading heads can be optimally customized by parameterization for specific requirements.

Displays and Controls

The PCV... reading head allows visual function check and fast diagnosis with 7 indicator LEDs. The reading head has 2 buttons on the reverse of the device to activate the alignment aid and parameterization mode.

LEDs

LED	Color	Label	Meaning
1	Yellow	BUS STATE	CANopen communication active
2	Red	BUS ERR	CANopen communication Error
3	Green/red	PWR/ADJ ERR/NO CODE	Code recognized/not recognized, Error
4	Yellow	OUT1	Output 1, configuration
5	Yellow	OUT2/ADJ Y	Output 2, Alignment aid Y
6	Yellow	OUT3/ADJ Z	Output 3, Alignment aid Z
7	red/green/yellow	INTERNAL DIAGNOSTICS	Internal diagnostics

External parameterization

For external parameterization you require the parameterization code as Data Matrix with the desired reading head parameters. Data Matrix code cards for step-by-step external parameterization are printed in the reading heads operating instructions.

Parameterization is only possible within 10 minutes of switching on the reading head. If a button is pressed after 10 minutes subsequent to switching on, there is visual signaling via the LEDs (LED1, yellow/LED2, red/LED3, green/LED4, yellow/LED5, yellow/LED6, yellow flash for 2 seconds)

- The switchover from normal operation to parameterization mode is via button 2 on the reverse of the reading head. Button 2 must be pressed for more than 2 seconds. LED4 now flashes.
- Note:**Parameterization mode automatically ends after 1 minute of inactivity. The reading head returns to normal operation and works with unchanged settings.
- Place the parameterization code in the view of the camera module. After recognition of the parameterization code, the green LED3 lights up for 1s. In the event of an invalid parameterization code, the red LED3 lights up for 2 s.
- A short press on button 2 ends the parameterization mode and the changed parameters are not stored volatile in the reading head.

Alignment aid for the Y and Z coordinates

The activation of the alignment aid is only possible within 10 minutes of switching on the reading head. The switchover from normal operation to "alignment aid operating mode is via button 1 on the reverse of the reading head.

- Press the button 1 for longer than 2 s. LED3 flashes green for a recognized code band. LED3 flashes red for an unrecognized code band.
- Z coordinate:** If the distance of the camera to the code band too small, the yellow LED6 lights up. If the distance of the camera to the code band too large, the yellow LED6 lights up. Within the target range, the yellow LED6 flashes at the same time as the green LED3.
- Y coordinate:** If the optical axis of the camera is too deep in relation to the middle of the code band, the yellow LED5 lights up. If the optical axis is too high, the yellow LED5 extinguishes. Within the target range, the yellow LED5 flashes at the same time as the green LED3.
- A short press on button 1 ends the alignment aid and the reading head changes to normal operation.