

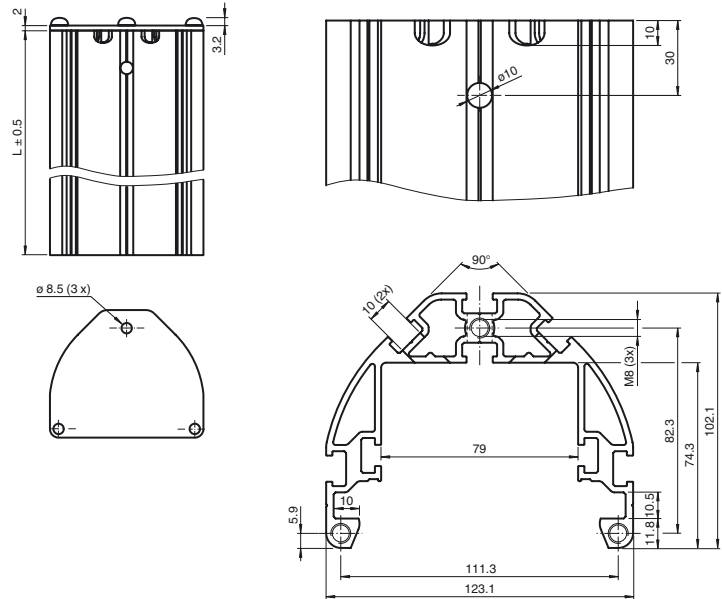

**Dimensions**



**Model Number**

**OMH-SLCT-100-2100**

Mounting base for floor mounting and cover plate

**Features**

- Eight grooves for mounting photoelectric sensors or accessories, three on the inside and five on the outside
- Corner mounting of photoelectric sensors with a directional difference of 90°
- Cover prepared for indicator light mounting

**Accessories**

**OMH-SLCT-200**

Floor mount

**OMH-SLCT-120-2100**

Side protection for mounting base

**OMH-SLCT-10**

Clamp mounting suitable for 6 mm ... 11.5 mm groove

**OMH-SLCT-11**

Reverse clamp mounting suitable for 8.5 mm ... 10.5 mm groove

**OMH-SLCT-12-500**

Mounting bracket, muting arm with round rod d=12 mm

**Technical data**

**General specifications**

Setting angle	± 5 ° with product OMH-SLCT-200
Tilting angle	± 2.5 ° with product OMH-SLCT-200

**Ambient conditions**

Ambient temperature	-40 ... 80 °C (-40 ... 176 °F)
Storage temperature	-40 ... 80 °C (-40 ... 176 °F)
Relative humidity	80 % , noncondensing

**Mechanical specifications**

Housing length L	2080 mm
Material	
Housing	anodized aluminum
Mass	approx. 9.9 kg

**General information**

Scope of delivery	Mounting base, cover plate The three fillister head screws for the cover plate are supplied with the floor mount
-------------------	---

Release date: 2017-10-04 09:53 Date of issue: 2017-10-04 251611\_eng.xml

Refer to "General Notes Relating to Pepperl+Fuchs Product Information".

Pepperl+Fuchs Group  
www.pepperl-fuchs.com

USA: +1 330 486 0001  
fa-info@us.pepperl-fuchs.com

Germany: +49 621 776 4411  
fa-info@de.pepperl-fuchs.com

Singapore: +65 6779 9091  
fa-info@sg.pepperl-fuchs.com

Mechanical arrangement

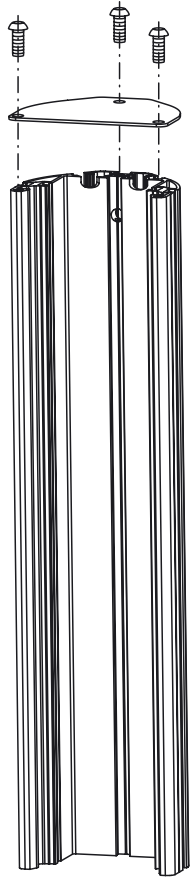

Release date: 2017-10-04 09:53 Date of issue: 2017-10-04 251611\_eng.xml