

Features

- 4-channel
- Inputs Ex ia
- Mounting in Zone 2, Class I/Div.2 or in the safe area
- Power supply for 2-wire transmitters with 4 mA ... 20 mA
- Supply circuit 15 V (20 mA)
- Input from active signals of 4-wire transmitters
- HART communication via field bus or service bus
- Simulation mode for service operations (forcing)
- Line fault detection (LFD): one LED per channel
- Permanently self-monitoring
- Module can be exchanged under voltage

Function

The transmitter power supply feeds 2-wire transmitters. Active signals from separately powered field devices and 4-wire transmitters can be connected. Open and short-circuit line faults are detected. The intrinsically safe inputs are galvanically isolated from the bus and the power supply.

Assembly

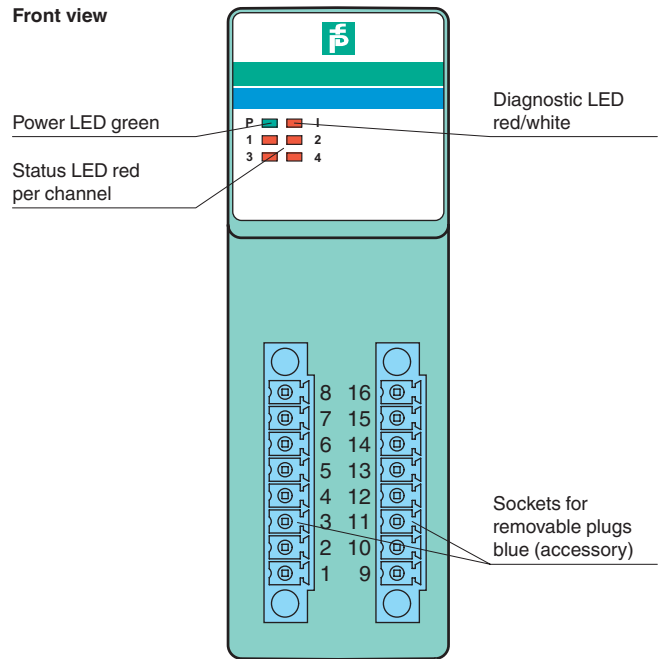

Connection

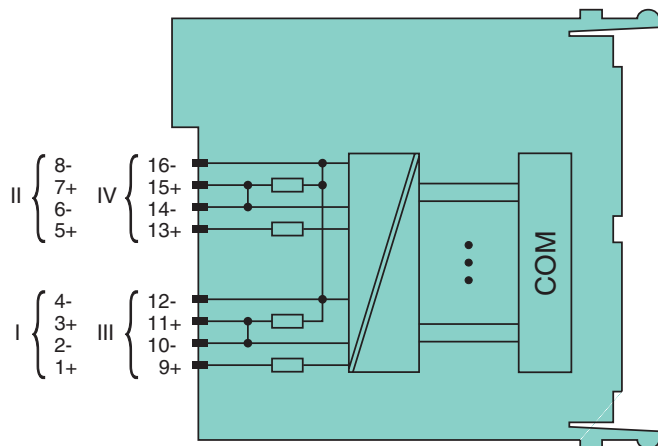
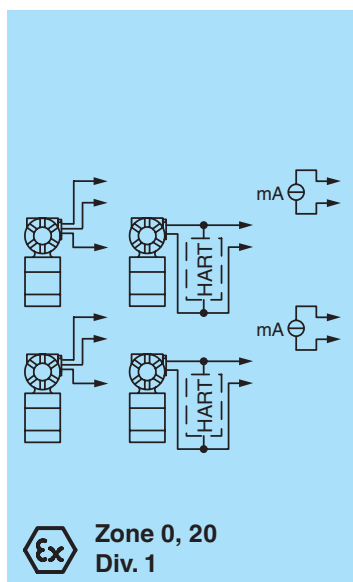

Zone 2
Div. 2

Release date 2018-09-14 09:48 Date of issue 2018-09-14 254710_eng.xml

Refer to "General Notes Relating to Pepperl+Fuchs Product Information".

Pepperl+Fuchs Group
www.pepperl-fuchs.com

USA: +1 330 486 0002
pa-info@us.pepperl-fuchs.com

Germany: +49 621 776 2222
pa-info@de.pepperl-fuchs.com

Singapore: +65 6779 9091
pa-info@sg.pepperl-fuchs.com

Slots	
Occupied slots	2
Supply	
Connection	backplane bus
Rated voltage	U_r 12 V DC , only in connection with the power supplies LB9***
Power dissipation	1.5 W
Power consumption	2.7 W
Internal bus	
Connection	backplane bus
Interface	manufacturer-specific bus to standard com unit
Analog input	
Number of channels	4
Suitable field devices	
Field device	pressure converter
Field device [2]	flow converter
Field device [3]	level converter
Field device [4]	Temperature Converter
Field device interface	
Connection	2-wire transmitter
Connection [2]	3-wire transmitter
Connection [3]	4-wire transmitter
Connection	2-wire transmitter (HART): Supply circuit: channel I 1+, 2-, channel II 5+, 6-, channel III 9+, 10-, channel IV 13+, 14- 3-wire transmitter: Supply circuit: channel I 1+, 4-, channel II 5+, 8-, channel III 9+, 12-, channel IV 13+, 16- Measurement loop: channel I 3+, 4-, channel II 7+, 8-, channel III 11+, 12-, channel IV 15+, 16- 4-wire transmitter (powered externally): Measurement loop: channel I 3+, 4-, channel II 7+, 8-, channel III 11+, 12-, channel IV 15+, 16-
Transmitter supply voltage	≥ 15 V at 20 mA ; 21.5 V at 4 mA
Input resistance	15 Ω
Conversion time	≤ 100 ms
Line fault detection	can be switched on/off for each channel via configuration tool , configurable via configuration tool
Short-circuit	factory setting: > 22 mA configurable between 0 ... 26 mA
Open-circuit	factory setting: < 1 mA configurable between 0 ... 26 mA
HART communication	yes
HART secondary variable	no
Transfer characteristics	
Deviation	
After calibration	0.1 % of the signal range at 20 °C (68 °F)
Influence of ambient temperature	0.1 %/10 K of the signal range
Resolution	12 Bit (0 ... 26 mA)
Refresh time	100 ms
Indicators/settings	
LED indication	Power LED (P) green: supply Diagnostic LED (I) red: module fault , red flashing: communication error , white: fixed parameter set (parameters from com unit are ignored) , white flashing: requests parameters from com unit Status LED (1-4) red: line fault (lead breakage or short circuit)
Coding	optional mechanical coding via front socket
Directive conformity	
Electromagnetic compatibility	
Directive 2014/30/EU	EN 61326-1:2006
Conformity	
Electromagnetic compatibility	
Degree of protection	IEC 60529:2000
Environmental test	EN 60068-2-14:2009
Shock resistance	EN 60068-2-27:2009
Vibration resistance	EN 60068-2-6:2008
Damaging gas	EN 60068-2-42:2003
Relative humidity	EN 60068-2-78:2001
Ambient conditions	
Ambient temperature	-20 ... 60 °C (-4 ... 140 °F)
Storage temperature	-25 ... 85 °C (-13 ... 185 °F)
Relative humidity	95 % non-condensing
Shock resistance	shock type I, shock duration 11 ms, shock amplitude 15 g, number of shocks 18

Release date 2018-09-14 09:48 Date of issue 2018-09-14 254710_eng.xml

Refer to "General Notes Relating to Pepperl+Fuchs Product Information".

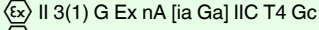
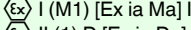
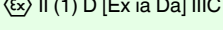
Vibration resistance	frequency range 10 ... 150 Hz; transition frequency: 57.56 Hz, amplitude/acceleration ± 0.075 mm/1 g; 10 cycles frequency range 5 ... 100 Hz; transition frequency: 13.2 Hz amplitude/acceleration ± 1 mm/0.7 g; 90 minutes at each resonance
Damaging gas	designed for operation in environmental conditions acc. to ISA-S71.04-1985, severity level G3
Mechanical specifications	
Degree of protection	IP20 when mounted on backplane
Connection	removable front connector with screw flange (accessory) wiring connection via spring terminals (0.14 ... 1.5 mm ²) or screw terminals (0.08 ... 1.5 mm ²)
Mass	approx. 150 g
Dimensions	32.5 x 100 x 102 mm (1.28 x 3.9 x 4 inch)
Data for application in connection with hazardous areas	
EU-Type Examination Certificate	BVS 12 ATEX E 024 X
Marking	  
Supply	
Voltage	U _o 27 V
Current	I _o 90 mA
Power	P _o 588 mW (linear characteristic)
Input	
Voltage	U _o 0.7 V
Current	I _o 2.78 mA
Power	P _o 2 mW (trapezoid characteristic curve)
Internal capacitance	C _i 242 nF
Internal inductance	L _i 0 mH
Galvanic isolation	
Input/power supply, internal bus	safe electrical isolation acc. to EN 60079-11, voltage peak value 375 V
Directive conformity	
Directive 2014/34/EU	EN 60079-0:2009 EN 60079-11:2012 EN 60079-15:2010 EN 60079-26:2007 EN 50303:2000
International approvals	
ATEX approval	BVS 12 ATEX E 024 X
UL approval	E106378
IECEx approval	BVS 12.0055X
Approved for	Ex nA [ia Ga] IIC T4 Gc [Ex ia Da] IIIC [Ex ia Ma] I
Marine approval	
Lloyd Register	15/20021
Bureau Veritas Marine	22449/B0 BV
General information	
System information	The module has to be mounted in appropriate backplanes (LB9***) in Zone 2 or outside hazardous areas. Here, observe the corresponding declaration of conformity. For use in hazardous areas (e. g. Zone 2, Zone 22 or Div. 2) the module must be installed in an appropriate enclosure.
Supplementary information	EC-Type Examination Certificate, Statement of Conformity, Declaration of Conformity, Attestation of Conformity and instructions have to be observed where applicable. For information see www.pepperl-fuchs.com .

Release date 2018-09-14 09:48 Date of issue 2018-09-14 254710_eng.xml