

Features

- 4-channel
- Analog output module for 0/4 mA ... 20 mA
- Installation in Zone 2 or safe area
- Module can be exchanged under voltage
- HART communication via field bus or service bus
- Simulation mode for service operations (forcing)
- Line fault detection (LFD): one LED per channel
- Permanently self-monitoring
- Output with bus-independent safety shutdown

Function

The device drives positioners, proportional valves, I/P converters, or local indicators.

Open and short circuit line faults are detected.

The outputs can be switched off via a contact. This can be used for bus-independent safety applications.

The outputs are galvanically isolated from the bus and the power supply.

Assembly

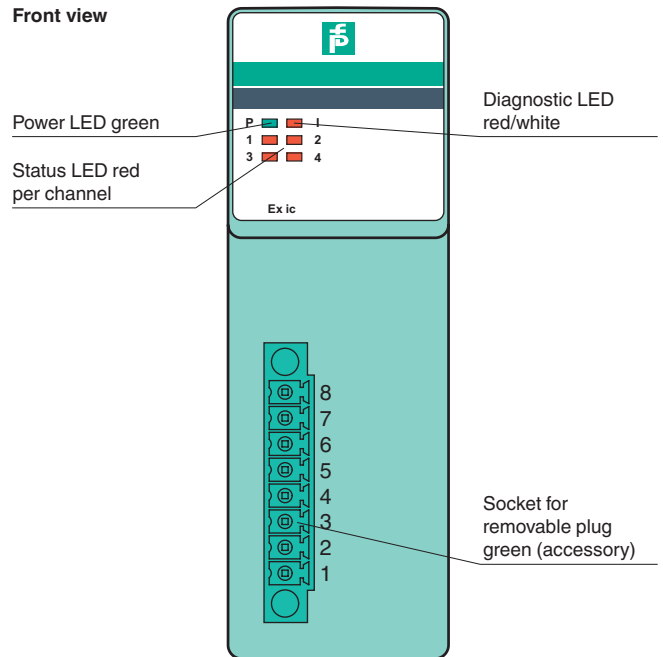

SIL2

Connection

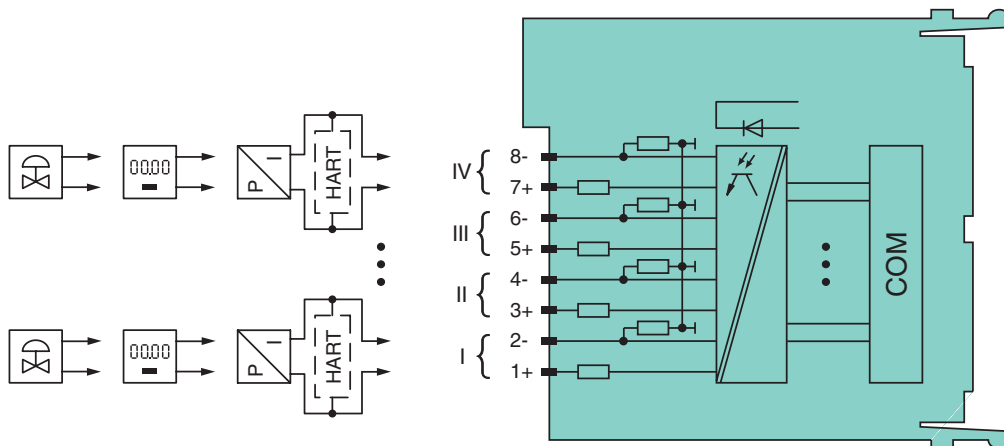

Zone 2

Release date 2018-09-14 09:53 Date of issue 2018-09-14 254720_eng.xml

Refer to "General Notes Relating to Pepperl+Fuchs Product Information".

Pepperl+Fuchs Group
www.pepperl-fuchs.com

USA: +1 330 486 0002
pa-info@us.pepperl-fuchs.com

Germany: +49 621 776 2222
pa-info@de.pepperl-fuchs.com

Singapore: +65 6779 9091
pa-info@sg.pepperl-fuchs.com

Slots	
Occupied slots	2
Supply	
Connection	backplane bus
Rated voltage	U_r 12 V DC , only in connection with the power supplies LB9***
Power dissipation	2.15 W
Power consumption	3.3 W
Internal bus	
Connection	backplane bus
Interface	manufacturer-specific bus to standard com unit
Analog input	
HART communication	yes
HART secondary variable	no
Analog output	
Number of channels	4
Suitable field devices	
Field device	Proportional Valve
Field device [2]	I/P converters
Field device [3]	on-site display
Connection	terminals 1+, 2-; 3+, 4-; 5+, 6-; 7+, 8-
Current	0 ... 25 mA short-circuit protected
Line fault detection	can be switched on/off for each channel via configuration tool , configurable via configuration tool
Short-circuit	factory setting: < 50 Ω configurable between 0 ... 26 mA
Open-circuit	deviation of preset output value > 0.5 mA
Load	750 Ω max.
HART communication	yes
HART secondary variable	yes
Watchdog	within 0.5 s the device goes in safe state, e.g. after loss of communication
Transfer characteristics	
Deviation	
After calibration	0.1 % of the signal range at 20 °C (68 °F)
Influence of ambient temperature	0.1 %/10 K of the signal range
Refresh time	100 ms
Indicators/settings	
LED indication	Power LED (P) green: supply Diagnostic LED (I) red: module fault , red flashing: communication error , white: fixed parameter set (parameters from com unit are ignored) , white flashing: requests parameters from com unit Status LED (1-4) red: line fault (lead breakage or short circuit)
Coding	optional mechanical coding via front socket
Directive conformity	
Electromagnetic compatibility	
Directive 2014/30/EU	EN 61326-1:2006
Conformity	
Electromagnetic compatibility	NE 21:2007
Degree of protection	IEC 60529:2000
Environmental test	EN 60068-2-14:2009
Shock resistance	EN 60068-2-27:2009
Vibration resistance	EN 60068-2-6:2008
Damaging gas	EN 60068-2-42:2003
Relative humidity	EN 60068-2-78:2001
Ambient conditions	
Ambient temperature	-20 ... 60 °C (-4 ... 140 °F) , 70 °C (non-Ex)
Storage temperature	-25 ... 85 °C (-13 ... 185 °F)
Relative humidity	95 % non-condensing
Shock resistance	shock type I, shock duration 11 ms, shock amplitude 15 g, number of shocks 18
Vibration resistance	frequency range 10 ... 150 Hz; transition frequency: 57.56 Hz, amplitude/acceleration \pm 0.075 mm/1 g; 10 cycles frequency range 5 ... 100 Hz; transition frequency: 13.2 Hz amplitude/acceleration \pm 1 mm/0.7 g; 90 minutes at each resonance
Damaging gas	designed for operation in environmental conditions acc. to ISA-S71.04-1985, severity level G3
Mechanical specifications	
Degree of protection	IP20 when mounted on backplane
Connection	removable front connector with screw flange (accessory) wiring connection via spring terminals (0.14 ... 1.5 mm ²) or screw terminals (0.08 ... 1.5 mm ²)
Mass	approx. 150 g
Dimensions	32.5 x 100 x 102 mm (1.28 x 3.9 x 4 inch)

Release date 2018-09-14 09:53 Date of issue 2018-09-14 254720_eng.xml

Refer to "General Notes Relating to Pepperl+Fuchs Product Information".

Pepperl+Fuchs Group
www.pepperl-fuchs.com

USA: +1 330 486 0002
pa-info@us.pepperl-fuchs.com

Germany: +49 621 776 2222
pa-info@de.pepperl-fuchs.com

Singapore: +65 6779 9091
pa-info@sg.pepperl-fuchs.com

Data for application in connection with hazardous areas	
Certificate	BVS 12 ATEX E 115 X
Marking	⊕ II 3 G Ex nA [ic] IIC T4 Gc
Galvanic isolation	
Output/power supply, internal bus	safe electrical isolation acc. to EN 60079-11, voltage peak value 375 V
Directive conformity	
Directive 2014/34/EU	EN 60079-0:2009 EN 60079-11:2007 EN 60079-15:2010
International approvals	
ATEX approval	BVS 12 ATEX E 115 X
IECEx approval	BVS 11.0068X
Approved for	Ex nAc [ic] IIC T4
Marine approval	
Lloyd Register	15/20021
Bureau Veritas Marine	22449/B0 BV
General information	
System information	The module has to be mounted in appropriate backplanes (LB9***) in Zone 2 or outside hazardous areas. Here, observe the corresponding declaration of conformity. For use in hazardous areas (e. g. Zone 2 or Zone 22) the module must be installed in an appropriate enclosure.
Supplementary information	EC-Type Examination Certificate, Statement of Conformity, Declaration of Conformity, Attestation of Conformity and instructions have to be observed where applicable. For information see www.pepperl-fuchs.com .

Release date 2018-09-14 09:53 Date of issue 2018-09-14 254720_eng.xml

Refer to "General Notes Relating to Pepperl+Fuchs Product Information".

Pepperl+Fuchs Group
www.pepperl-fuchs.com

USA: +1 330 486 0002
pa-info@us.pepperl-fuchs.com

Germany: +49 621 776 2222
pa-info@de.pepperl-fuchs.com

Singapore: +65 6779 9091
pa-info@sg.pepperl-fuchs.com