

Dimensions

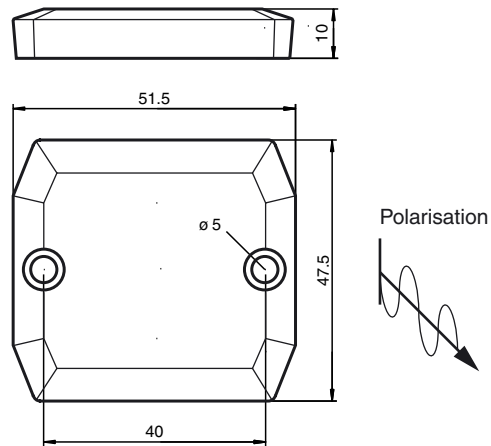

Model Number

IUC77-F151-M-GBL

Data carrier

Features

- Operating frequency 865 ... 928 MHz
- Complies with EPC Gen2 (ISO/IEC 18000-63)
- Sturdy housing, suitable for rough industrial use

Technical data

General specifications

Operating frequency	865 ... 928 MHz
Polarization	linear

Memory

Chip Type	Monza 4QT (Impinj)
Memory Bank 00 (Reserved)	64 Bit
Memory Bank 01 (EPC/UJI)	128 Bit
Memory Bank 10 (TID)	96 Bit
Memory Bank 11 (User memory)	512 Bit
Read cycles	unlimited
Write cycles	> 100000
Data retention period	10 years

Directive conformity

Electromagnetic compatibility	
R&TTE Directive 1995/5/EC	EN 302208-2:2011 V1.4.1

Standard conformity

Electromagnetic compatibility	EN 302208-2:2011 V1.4.1
Degree of protection	EN 60529:2000
RFID	ISO/IEC 18000-63:2013

Ambient conditions

Ambient temperature	-40 ... 85 °C (-40 ... 185 °F)
Storage temperature	-40 ... 85 °C (-40 ... 185 °F)

Mechanical specifications

Degree of protection	IP68
Material	
Housing	Impact-resistant plastic material
Installation	
On metal	yes
Mass	22 g
Construction type	Rectangular type