

**Features**

- 1-channel isolated barrier
- 24 V DC supply (Power Rail)
- Resistance and RTD input (Pt100, Pt500, Pt1000)
- Resistance output
- Accuracy 0.1 %
- Housing width 12.5 mm
- Up to SIL 2 acc. to IEC 61508

**Function**

This isolated barrier is used for intrinsic safety applications. It transfers resistance values of RTDs or potentiometers from hazardous areas to safe areas. A 2-, 3-, or 4-wire technique is available depending on the required accuracy. The input card of the control system measures the same load as if it were connected directly to the resistance in a hazardous area.

**Assembly**

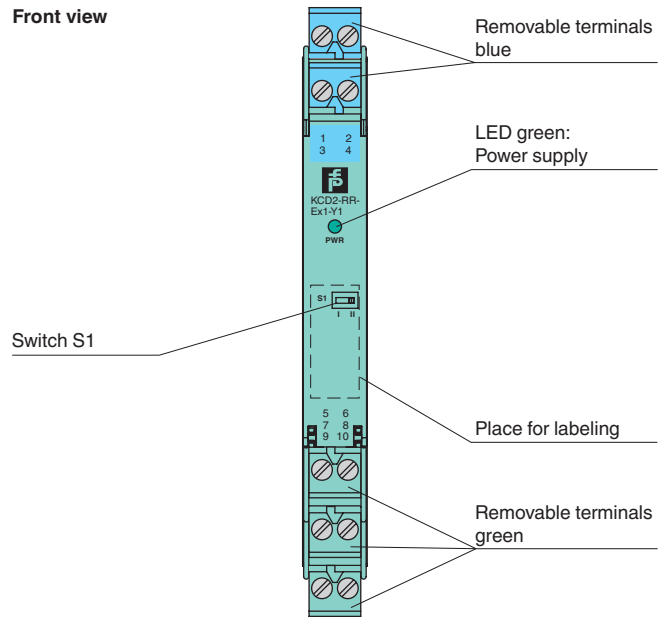

**Connection**

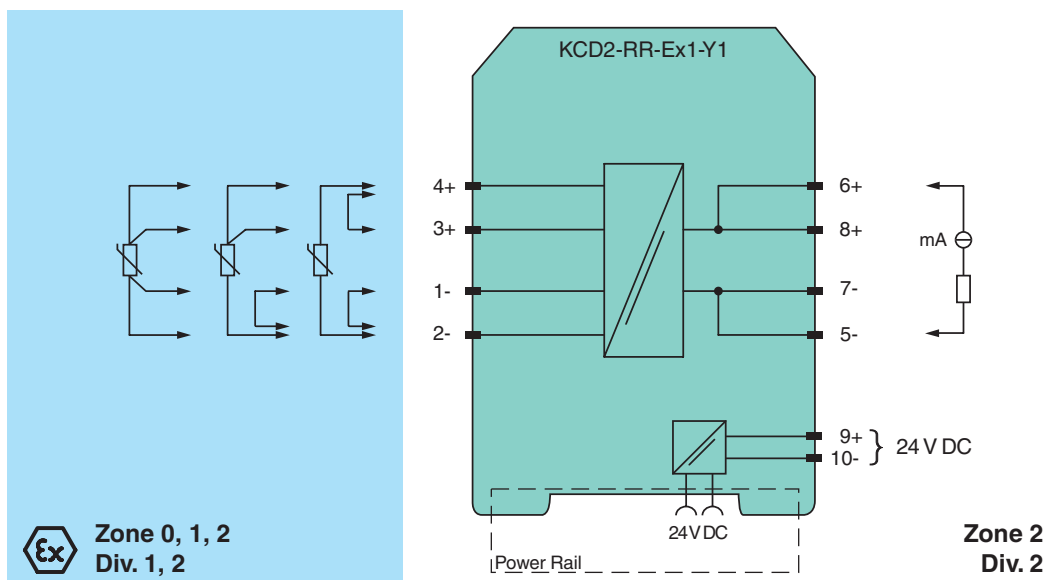

Release date 2019-01-24 13:56 Date of issue 2019-01-24 258828\_eng.xml

Refer to "General Notes Relating to Pepperl+Fuchs Product Information".

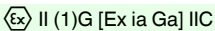
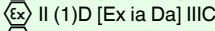
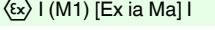
<b>General specifications</b>		
Signal type		Analog input
<b>Functional safety related parameters</b>		
Safety Integrity Level (SIL)		SIL 2
<b>Supply</b>		
Connection		Power Rail or terminals 9+, 10-
Rated voltage	$U_r$	19 ... 30 V DC
Ripple		within the supply tolerance
Rated current	$I_r$	< 20 mA
Power consumption		0.35 W (24 V and 1 mA sense current)
<b>Input</b>		
Connection side		field side
Connection		terminals 1, 2, 3, 4
Lead resistance		≤ 10 % of resistance value
Transmission range		0 ... 10 mA
Available voltage		9 V
<b>Output</b>		
Connection side		control side
Connection		terminals 5-, 7-, 6+, 8+
Current		0 ... 10 mA
Available voltage		0 ... 7 V
<b>Transfer characteristics</b>		
Accuracy		0.1 %
Deviation		$I_m \geq 1 \text{ mA}$ : $\pm 0.1 \%$ of $R_m$ or $\pm 0.1 \Omega$ (the larger value is applicable) $I_m < 1 \text{ mA}$ : accuracy reduces in proportion to $I_m$ . e. g. $I_m = 0.1 \text{ mA}$ : $\pm 1 \%$ of $R_m$ or $1 \Omega$ (the larger value is applicable).
Influence of ambient temperature		$I_m \geq 1 \text{ mA}$ , $R_m \geq 100 \Omega$ : 0.01 %/K in the range -20 ... +60 °C (253 ... 333 K) $I_m < 1 \text{ mA}$ or $R_m < 100 \Omega$ : temperature stability reduces in proportion to $I_m$ or $R_m$
Rise time		signal response time ≤ 2 ms (10 ... 90 %) response to application of $I_m$ : $R_m > 50 \Omega$ and $I_m < 5 \text{ mA}$ : < 5ms response to application of $I_m$ : $R_m > 30 \Omega$ and $I_m < 5 \text{ mA}$ : < 10ms response to application of $I_m$ : $R_m > 18 \Omega$ and $I_m < 5 \text{ mA}$ : < 20ms
<b>Galvanic isolation</b>		
Input/Output		reinforced insulation acc. to EN 50178, rated insulation voltage 300 V <sub>eff</sub>
Input/power supply		reinforced insulation acc. to EN 50178, rated insulation voltage 300 V <sub>eff</sub>
Output/power supply		functional insulation, rated insulation voltage 50 V AC
<b>Indicators/settings</b>		
Display elements		LED
Control elements		DIP-switch
Configuration		via DIP switches
Labeling		space for labeling at the front
<b>Directive conformity</b>		
Electromagnetic compatibility Directive 2014/30/EU		EN 61326-1:2013 (industrial locations)
<b>Conformity</b>		
Electromagnetic compatibility		NE 21:2011
Degree of protection		IEC 60529:2001
Protection against electrical shock		UL 61010-1
<b>Ambient conditions</b>		
Ambient temperature		-20 ... 60 °C (-4 ... 140 °F)
<b>Mechanical specifications</b>		
Degree of protection		IP20
Connection		screw terminals
Mass		approx. 100 g
Dimensions		12.5 x 114 x 124 mm (0.5 x 4.5 x 4.9 inch) , housing type A2
Mounting		on 35 mm DIN mounting rail acc. to EN 60715:2001
<b>Data for application in connection with hazardous areas</b>		
EU-Type Examination Certificate		BASEEFA 10 ATEX 0061
Marking		  
Input		[Ex ia Ga] IIC, [Ex ia Da] IIIC, [Ex ia Ma] I
Voltage	$U_o$	12.4 V
Current	$I_o$	17.4 mA
Power	$P_o$	54 mW

Release date 2019-01-24 13:56 Date of issue 2019-01-24 258828\_eng.xml

Refer to "General Notes Relating to Pepperl+Fuchs Product Information".

<b>Supply</b>		
Maximum safe voltage	U <sub>m</sub>	253 V (Attention! The rated voltage can be lower.)
Type of protection [EEx ia]		
<b>Output</b>		
Maximum safe voltage	U <sub>m</sub>	253 V (Attention! The rated voltage can be lower.)
Certificate		
BASEEFA 10 ATEX 0062X		
Marking		
⊕ II 3G Ex ec IIC T4 Gc		
<b>Galvanic isolation</b>		
Input/Output		
safe electrical isolation acc. to IEC/EN 60079-11:2012, voltage peak value 375 V		
Input/power supply		
safe electrical isolation acc. to IEC/EN 60079-11:2012, voltage peak value 375 V		
Directive conformity		
Directive 2014/34/EU		
EN 60079-0:2012+A11:2013 , EN 60079-11:2012 , EN 60079-7:2015		
<b>International approvals</b>		
<b>FM approval</b>		
Control drawing		
116-0129 (cFMus)		
<b>UL approval</b>		
Control drawing		
116-0332 (cULus)		
<b>IECEx approval</b>		
IECEx BAS 10.0024		
IECEx BAS 10.0025X		
Approved for		
[Ex ia Ga] IIC , [Ex ia Da] IIIC , [Ex ia Ma] I , Ex ec IIC T4 Gc		
<b>General information</b>		
Supplementary information		
Observe the certificates, declarations of conformity, instruction manuals, and manuals where applicable. For information see <a href="http://www.pepperl-fuchs.com">www.pepperl-fuchs.com</a> .		
<b>Accessories</b>		
Optional accessories		
<ul style="list-style-type: none"> <li>- power feed module KFD2-EB2(.R4A.B)(.SP)</li> <li>- universal power rail UPR-03(-M)(-S)</li> <li>- profile rail K-DUCT-BU(-UPR-03)</li> <li>- insertion bridge EBP 2- 5</li> </ul>		

Release date 2019-01-24 13:56 Date of issue 2019-01-24 258828\_eng.xml

Refer to "General Notes Relating to Pepperl+Fuchs Product Information".

Pepperl+Fuchs Group  
www.pepperl-fuchs.com

USA: +1 330 486 0002  
pa-info@us.pepperl-fuchs.com

Germany: +49 621 776 2222  
pa-info@de.pepperl-fuchs.com

Singapore: +65 6779 9091  
pa-info@sg.pepperl-fuchs.com

**Additional information**

**Function**

When a signal converter, a DCS or PLC is connected to terminals 5, 6, 7, and 8 (control side), the measuring current is transferred to terminals 2 and 4 (field side). The resulting voltage at terminals 1, and 3 is transferred to terminals 5, 6, 7, and 8. In the case of fast multiplex input cards, transmission problems might be experienced in connection with low resistance values and/or high sensor currents. For data see rise time.

The quoted accuracy is for a 4-wire technique connection. The accuracy in 3-wire technique will depend on the matching of the line resistance.

**Connection types control side (safe area)**

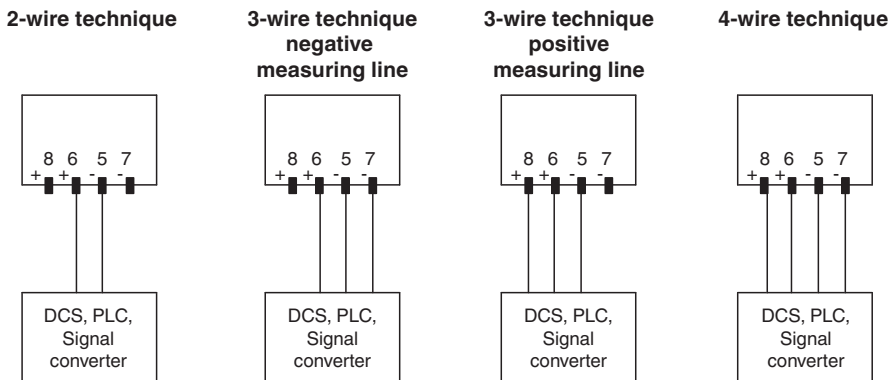

**Connection types field side (hazardous area)**

The resistance in the hazardous area can be measured with a 2-, 3- or 4-wire technique.

- 2-wire technique: Link terminals 1 and 2 and terminals 3 and 4. Connect the resistance to terminal 4 and terminal 2. Switch S1 in the position II.
- 3-wire technique: Link terminals 1 and 2. Connect the resistance to terminals 3 and 4 and terminal 2. Switch S1 in the position I.
- 4-wire technique: Connect the resistance to terminals 3 and 4 and terminals 1 and 2. Switch S1 in the position II.

**Measurement range**

The resistance repeater can convey a maximum of 10 mA and a maximum of 7 V. The maximum connectable resistance value can be calculated with the following equations

- Resistance value = 7 V / measuring current
- Resistance value = 9 V / measuring current - 758 Ω

Use the smaller of these two resistance values as maximum allowed load.

The measuring current is determined by control.

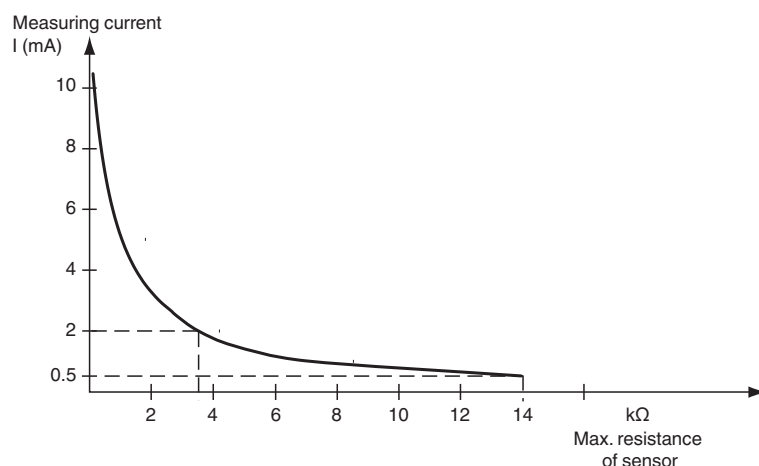

An example of the maximum transferable resistance value:

- 14 kΩ at 0.5 mA measuring current
- 3.5 kΩ at 2 mA measuring current

Release date 2019-01-24 13:56 Date of issue 2019-01-24 258828\_eng.xml