

**Features**

- 2-channel signal conditioner
- 24 V DC supply (Power Rail)
- Dry contact or NAMUR inputs
- Usable as signal splitter (1 input and 2 outputs)
- 2 x 2 relay contact outputs with AND logic
- Line fault detection (LFD)
- Reversible mode of operation
- Up to SIL 2 acc. to IEC 61508/IEC 61511

**Function**

This signal conditioner provides the galvanic isolation between field circuits and control circuits.

The device transfers digital signals (NAMUR sensors or dry contacts) from the field to the control system.

Each input controls a relay contact output.

Via switches the mode of operation can be reversed and the line fault detection can be switched off.

A fault is signaled by LEDs acc. to NAMUR NE44 and a separate collective error message output.

**Assembly**

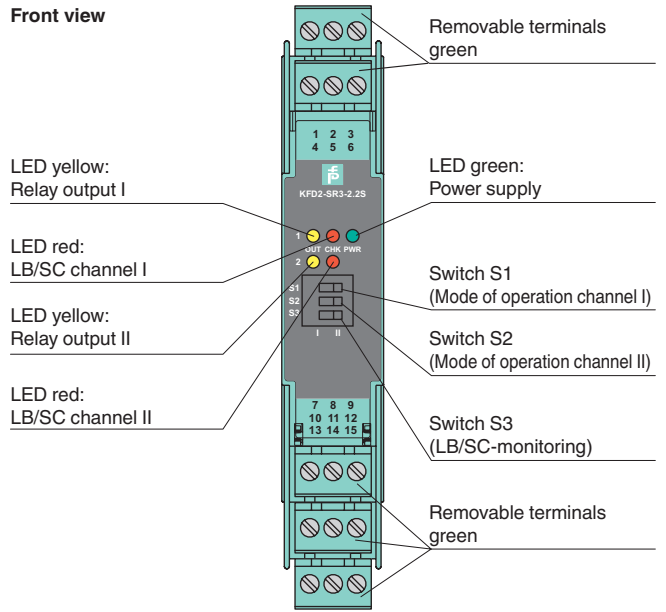

CE

SIL 2

**Connection**

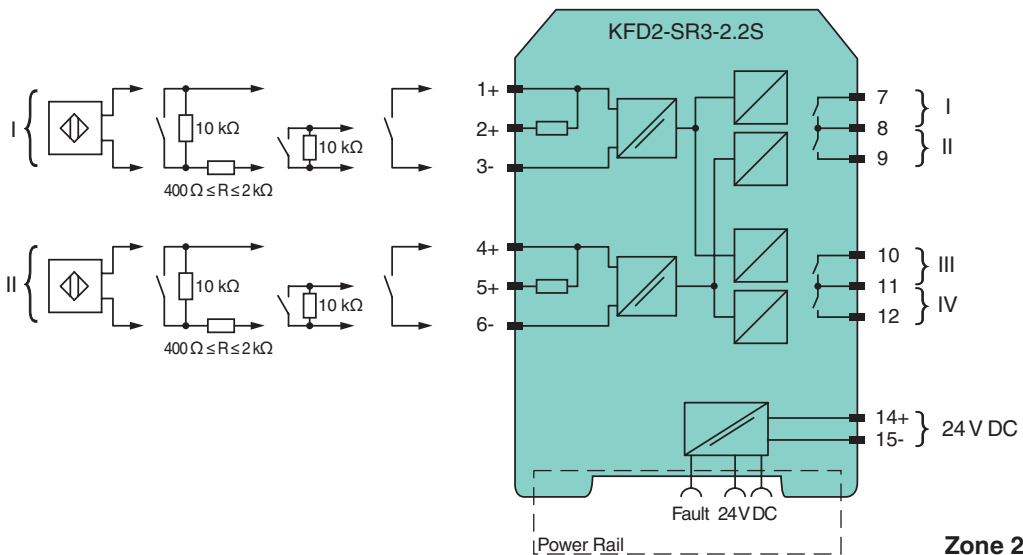

Release date 2018-05-08 08:09 Date of issue 2018-05-08 262113\_eng.xml

Refer to "General Notes Relating to Pepperl+Fuchs Product Information".

<b>General specifications</b>		
Signal type		Digital Input
<b>Functional safety related parameters</b>		
Safety Integrity Level (SIL)		SIL 2
<b>Supply</b>		
Connection		Power Rail or terminals 14+, 15-
Rated voltage	$U_r$	19 ... 30 V DC
Ripple		≤ 10 %
Rated current	$I_r$	30 ... 20 mA
Power consumption		< 600 mW
<b>Input</b>		
Connection side		field side
Connection		terminals 1+, 2+, 3-; 4+, 5+, 6-
Rated values		acc. to EN 60947-5-6 (NAMUR)
Open circuit voltage/short-circuit current		approx. 10 V DC / approx. 8 mA
Switching point/switching hysteresis		1.2 ... 2.1 mA / approx. 0.2 mA
Line fault detection		breakage $I \leq 0.1$ mA , short-circuit $I \geq 6.5$ mA
Pulse/Pause ratio		≥ 20 ms / ≥ 20 ms
<b>Output</b>		
Connection side		control side
Connection		output I: terminals 7, 8 ; output II: terminals 8, 9 ; output III: terminals 10, 11 ; output IV: terminals 11, 12
Output I, II, III, IV		channel 1, 2; relay
Contact loading		48 V AC/1 A/cos $\phi > 0.7$ ; 40 V DC/1 A resistive load
Minimum switch current		1 mA / 24 V DC
Energized/De-energized delay		approx. 20 ms / approx. 20 ms
Mechanical life		10 <sup>8</sup> switching cycles
Collective error message		Power Rail
<b>Transfer characteristics</b>		
Switching frequency		≤ 10 Hz
<b>Galvanic isolation</b>		
Input/Output		reinforced insulation according to IEC/EN 61010-1, rated insulation voltage 300 V <sub>eff</sub>
Input/power supply		reinforced insulation according to IEC/EN 61010-1, rated insulation voltage 300 V <sub>eff</sub>
Output/power supply		basic insulation according to IEC/EN 61010-1, rated insulation voltage 32 V <sub>eff</sub> , functional insulation, rated insulation voltage 50 V <sub>eff</sub>
Output/Output		basic insulation according to IEC/EN 61010-1, rated insulation voltage 32 V <sub>eff</sub> , functional insulation, rated insulation voltage 50 V <sub>eff</sub>
<b>Indicators/settings</b>		
Display elements		LEDs
Control elements		DIP-switch
Configuration		via DIP switches
Labeling		space for labeling at the front
<b>Directive conformity</b>		
Electromagnetic compatibility		
Directive 2014/30/EU		EN 61326-1:2013 (industrial locations)
<b>Conformity</b>		
Electromagnetic compatibility		NE 21:2012 , EN 61326-3-2:2008
Degree of protection		IEC 60529:2001
Input		EN 60947-5-6:2000
<b>Ambient conditions</b>		
Ambient temperature		-20 ... 60 °C (-4 ... 140 °F)
<b>Mechanical specifications</b>		
Degree of protection		IP20
Connection		screw terminals
Mass		approx. 150 g
Dimensions		20 x 119 x 115 mm (0.8 x 4.7 x 4.5 inch) , housing type B2
Mounting		on 35 mm DIN mounting rail acc. to EN 60715:2001
<b>Data for application in connection with hazardous areas</b>		
Certificate		PF 16 CERT 3903 X
Marking		 II 3G Ex nA nC IIC T4 Gc
Directive conformity		
Directive 2014/34/EU		EN 60079-0:2012+A11:2013 , EN 60079-15:2010
<b>International approvals</b>		
IECEX approval		IECEX EXA 16.0001X
Approved for		Ex nA nC IIC T4 Gc

Release date 2018-05-08 08:09 Date of issue 2018-05-08 262113\_eng.xml

Refer to "General Notes Relating to Pepperl+Fuchs Product Information".

Pepperl+Fuchs Group  
www.pepperl-fuchs.com

USA: +1 330 486 0002  
pa-info@us.pepperl-fuchs.com

Germany: +49 621 776 2222  
pa-info@de.pepperl-fuchs.com

Singapore: +65 6779 9091  
pa-info@sg.pepperl-fuchs.com

<b>General information</b>	
Supplementary information	Observe the certificates, declarations of conformity, instruction manuals, and manuals where applicable. For information see <a href="http://www.pepperl-fuchs.com">www.pepperl-fuchs.com</a> .
<b>Accessories</b>	
Optional accessories	power feed module KFD2-EB2 Universal Power Rail UPR-03 Universal Power Rail UPR-03-S profile rail K-DUCT-BU profile rail K-DUCT-UPR-03

Release date 2018-05-08 08:09 Date of issue 2018-05-08 262113\_eng.xml

Refer to "General Notes Relating to Pepperl+Fuchs Product Information".

Pepperl+Fuchs Group  
www.pepperl-fuchs.com

USA: +1 330 486 0002  
pa-info@us.pepperl-fuchs.com

Germany: +49 621 776 2222  
pa-info@de.pepperl-fuchs.com

Singapore: +65 6779 9091  
pa-info@sg.pepperl-fuchs.com

**Configuration**

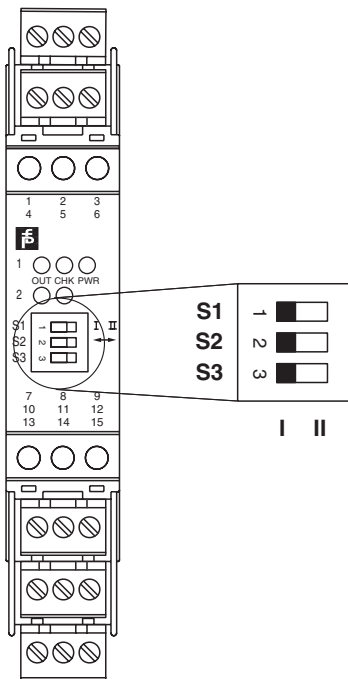

**Switch position**

S	Function		Position
1	Mode of operation Channel I (relay) energized	with high input current	I
		with low input current	II
2	Mode of operation Channel II (relay) energized	with high input current	I
		with low input current	II
3	Line fault detection	ON	I
		OFF	II

**Operating status**

Control circuit	Input signal
Initiator high impedance/ contact opened	low input current
Initiator low impedance/ contact closed	high input current
Lead breakage, lead short-circuit	Line fault

Factory settings: switch 1, 2 and 3 in position I

**Maximal Switching Power of Output Contacts**

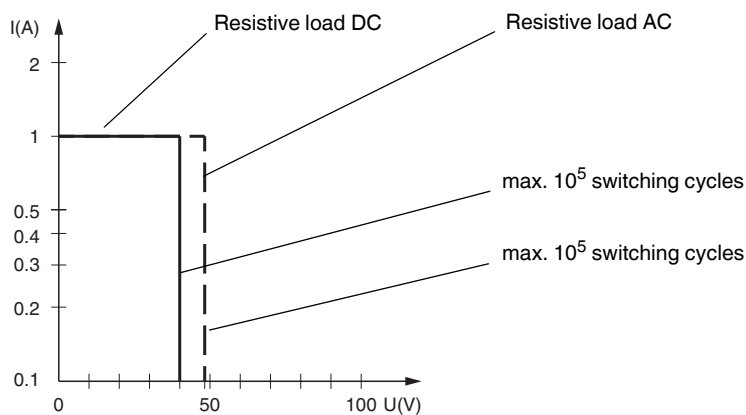

Release date 2018-05-08 08:09 Date of issue 2018-05-08 262113\_eng.xml

Refer to "General Notes Relating to Pepperl+Fuchs Product Information".