

Features

- 1-channel isolated barrier
- 24 V DC supply (bus powered)
- Input for 2-wire SMART transmitters and current sources
- Signal splitter (1 input and 2 outputs)
- Dual output 0/4 mA ... 20 mA or 0/1 V ... 5 V
- Up to SIL 2 acc. to IEC 61508

Function

This isolated barrier is used for intrinsic safety applications. The device supplies 2-wire transmitters in the hazardous area, and can also be used with current sources.

It transfers the analog input signal to the safe area as two isolated output signals.

Bi-directional communication is supported for SMART transmitters that use current modulation to transmit data and voltage modulation to receive data.

The output is selected as a current source, current sink, or voltage source via switches.

This device mounts on a HiC Termination Board.

Application

The device supports the following SMART protocols:

- HART
- BRAIN
- Honeywell DE

Assembly

Front view

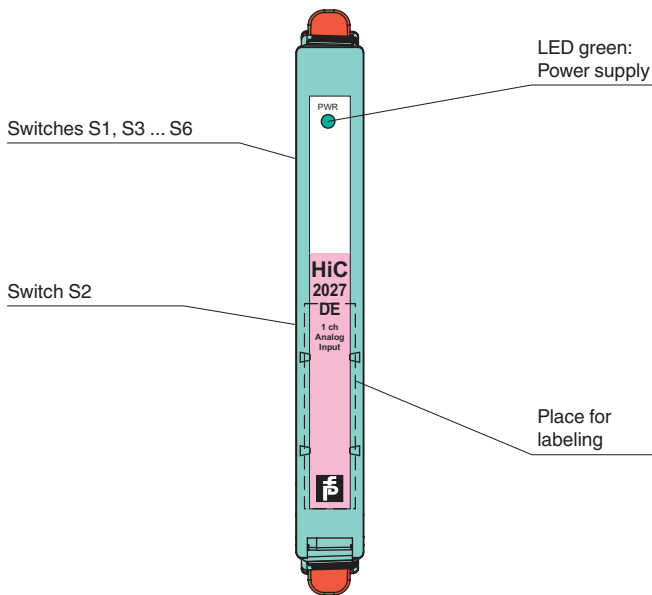

Connection

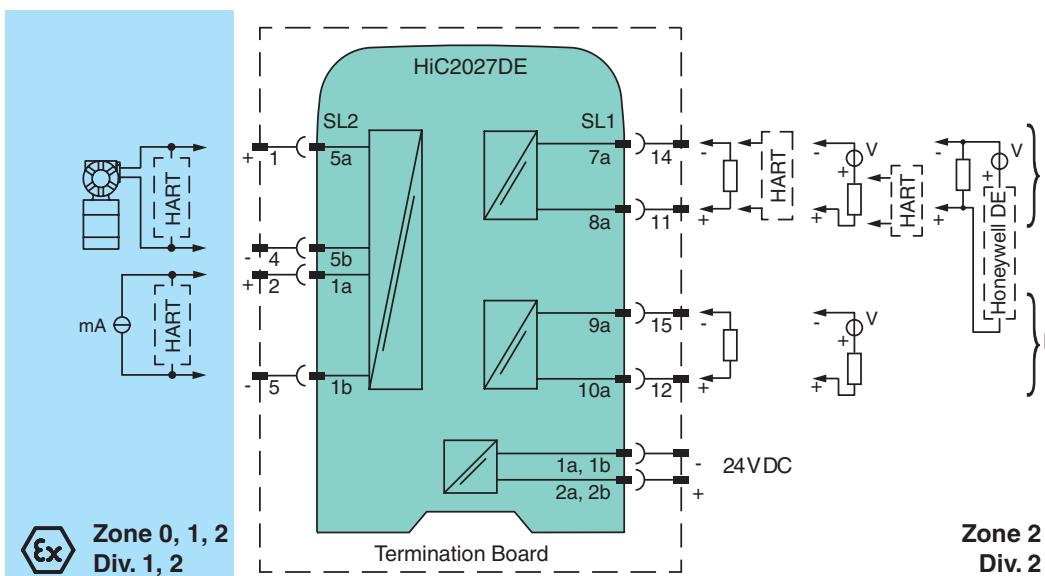

Release date 2018-03-14 16:41 Date of issue 2018-03-14 272953_eng.xml

Refer to "General Notes Relating to Pepperl+Fuchs Product Information".

Pepperl+Fuchs Group
www.pepperl-fuchs.com

USA: +1 330 486 0002
pa-info@us.pepperl-fuchs.com

Germany: +49 621 776 2222
pa-info@de.pepperl-fuchs.com

Singapore: +65 6779 9091
pa-info@sg.pepperl-fuchs.com

General specifications	
Signal type	Analog input
Functional safety related parameters	
Safety Integrity Level (SIL)	SIL 2
Supply	
Connection	SL1: 1a, 1b(-); 2a, 2b(+)
Rated voltage U_r	18 ... 30 V DC bus powered via Termination Board
Ripple	within the supply tolerance
Power dissipation	approx. 1.4 W at 20 mA transfer current, 250 Ω in both outputs
Power consumption	2 W
Input	
Connection side	field side
Connection	SL2: 5a(+), 5b(-): sink SL2: 1a(+), 1b(-), 7a(-): source
Input signal	0/4 ... 20 mA
Voltage drop	SL2: 1a(+), 1b(-), 7a(-): ≤ 6.1 V at 20 mA
Short-circuit current	SL2: 5a(+), 5b(-): 25 mA , wake up pulse: 36 mA, 20 ms (Honeywell DE)
Input resistance	SL2: 5a(+), 5b(-): ≤ 500 Ω (250 Ω load)
Available voltage	SL2: 5a(+), 5b(-): ≥ 16 V at 20 mA , ≥ 18.5 V at 4 mA
Output	
Connection side	control side
Connection	SL1: 8a(+), 7a(-), channel 1: source and sink SL1: 10a(+), 9a(-), channel 2: source and sink
Load	channel 1: 0 ... 500 Ω (20 mA)/ > 1 M Ω (5 V) channel 2: 0 ... 500 Ω (20 mA)/ > 1 M Ω (5 V)
Output signal	0/4 ... 20 mA or 0/1 ... 5 V
Ripple	≤ 50 μ A _{rms}
Transfer characteristics	
Deviation	$I_{out} < 20$ μ A (0.1 %); $V_{out} < 10$ mV (0.2 %) incl. calibration, linearity, hysteresis and fluctuation of supply voltage, at 20 °C (68 °F), 0/4 ... 20 mA, 0/1 ... 5 V
Influence of ambient temperature	current output: 0.25 μ A/K voltage output: 80 μ V/K
Frequency range	field side into the control side: bandwidth with 0.5 V _{pp} signal 0 ... 6 kHz (-3 dB) control side into the field side: bandwidth with 0.5 V _{pp} signal 0.3 ... 6 kHz (-3 dB) [DE 1 kHz (-3 dB)]
Settling time	6 ms
Rise time/fall time	2 ms
Galvanic isolation	
Output/power supply	functional insulation, rated insulation voltage 50 V AC
Output/Output	functional insulation, rated insulation voltage 50 V AC
Indicators/settings	
Display elements	LED
Control elements	DIP-switch
Configuration	via DIP switches
Labeling	space for labeling at the front
Directive conformity	
Electromagnetic compatibility	
Directive 2014/30/EU	EN 61326-1:2013 (industrial locations)
Conformity	
Electromagnetic compatibility	NE 21:2012 EN 61326-3-2:2008
Degree of protection	IEC 60529:2001
Protection against electrical shock	UL 61010-1:2012
Ambient conditions	
Ambient temperature	-20 ... 60 °C (-4 ... 140 °F)
Mechanical specifications	
Degree of protection	IP20
Mass	approx. 100 g
Dimensions	12.5 x 128 x 106 mm (0.5 x 5.1 x 4.2 inch)
Mounting	on Termination Board
Coding	pin 2 and 3 trimmed For further information see system description.
Data for application in connection with hazardous areas	
EU-Type Examination Certificate	BASEEFA 13 ATEX 0075 X

Release date 2018-03-14 16:41 Date of issue 2018-03-14 272953_eng.xml

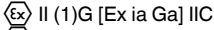
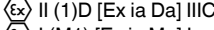
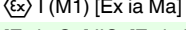
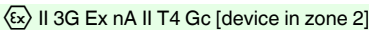
Marking		  
Input		[Ex ia Ga] IIC, [Ex ia Da] IIIC, [Ex ia Ma] I
Supply		
Maximum safe voltage	U_m	250 V (Attention! The rated voltage can be lower.)
Equipment		terminals 5a, 5b
Voltage	U_o	25.2 V
Voltage	U_q	28.2 V
Current	I_o	93 mA
Power	P_o	656 mW
Equipment		terminals 1a, 1b, 7a
Voltage	U_i	30 V
Current	I_i	115 mA
Power	P_i	700 mW
Voltage	U_o	5 V
Current	I_o	6.8 mA
Power	P_o	1.6 mW
Output		
Maximum safe voltage	U_m	250 V (Attention! The rated voltage can be lower.)
Certificate		BASEEFA 13 ATEX 0076 X
Marking		
Galvanic isolation		
Input/Output		safe electrical isolation acc. to IEC/EN 60079-11, voltage peak value 375 V
Input/power supply		safe electrical isolation acc. to IEC/EN 60079-11, voltage peak value 375 V
Directive conformity		
Directive 2014/34/EU		EN 60079-0:2012+A11:2013 , EN 60079-11:2012 , EN 60079-15:2010
International approvals		
UL approval		
Control drawing		116-0349 (cULus)
IECEX approval		IECEX BAS 13.0042X
Approved for		[Ex ia Ga] IIC, [Ex ia Da] IIIC, [Ex ia Ma] I
General information		
Note		Both output loads must be connected to ensure complete and correct operation within the technical specification.
Supplementary information		Observe the certificates, declarations of conformity, instruction manuals, and manuals where applicable. For information see www.pepperl-fuchs.com .

Release date 2018-03-14 16:41 Date of issue 2018-03-14 272953_eng.xml

Refer to "General Notes Relating to Pepperl+Fuchs Product Information".

Pepperl+Fuchs Group
www.pepperl-fuchs.com

USA: +1 330 486 0002
pa-info@us.pepperl-fuchs.com

Germany: +49 621 776 2222
pa-info@de.pepperl-fuchs.com

Singapore: +65 6779 9091
pa-info@sg.pepperl-fuchs.com

Configuration

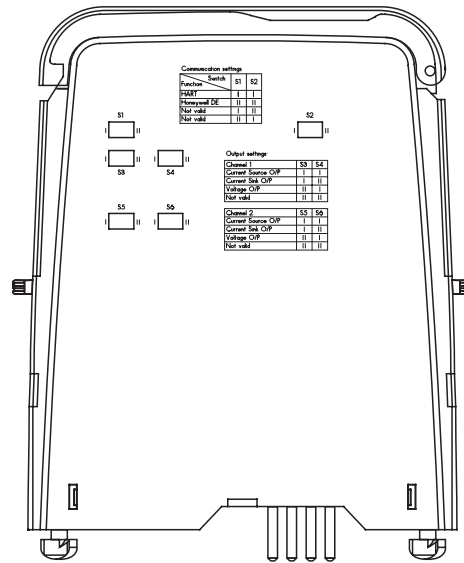

Communication switch settings

Function	S1	S2
HART transparency	I	I
Honeywell DE transparency	II	II
Not valid	I	II
Not valid	II	I

Output switch settings

Channel 1	S3	S4
Current source output	I	I
Current sink output	I	II
Voltage output	II	I
Not valid	II	II

Channel 2	S5	S6
Current source output	I	I
Current sink output	I	II
Voltage output	II	I
Not valid	II	II

Factory settings: current source output, for both channels with HART transparency.

Release date 2018-03-14 16:41 Date of issue 2018-03-14 272953_eng.xml

The device has a predecessor which has other position and function of the switches. The differences between the switches and their function can be seen in the following table.

Previous device					New device		
HiC2027DE, part number 230687					HiC2027DE, part number 272953		
Communication switch settings					Communication switch settings		
Function	S1.1	S1.2	S2.4	S2.8	Function	S1	S2
HART transparency	OFF	OFF	ON	OFF	HART transparency	I	I
Honeywell DE transparency	ON	ON	OFF	ON	Honeywell DE transparency	II	II
-					Not valid	I	II
-					Not valid	II	I
Output switch settings					Output switch settings		
Channel 1	S2.5	S2.6	S2.7	Channel 1	S3	S4	
Current source output	ON	OFF	OFF	Current source output	I	I	
Current sink output	OFF	ON	OFF	Current sink output	I	II	
Voltage output	ON	OFF	ON	Voltage output	II	I	
-				Not valid	II	II	
Channel 2	S2.1	S2.2	S2.3	Channel 2	S5	S6	
Current source output	ON	OFF	OFF	Current source output	I	I	
Current sink output	OFF	ON	OFF	Current sink output	I	II	
Voltage output	ON	OFF	ON	Voltage output	II	I	
-				Not valid	II	II	

Factory settings: current source output, for both channels with HART transparency.

Configure the device in the following way:

- Push the red Quick Lok Bars on each side of the device in the upper position.
- Remove the device from Termination Board.
- Set the DIP switches according to the figure.



The pins for this device are trimmed to polarize it according to its safety parameter. Do not change!
For further information see system description.