



### Model Number

**IPT-HH27**

Handheld (125 kHz)

### Features

- Suitable for IPC data carrier
- Robust design, suitable for indoor and outdoor use
- Simple handling via large touch display and keyboard
- Keypad for entry of alphanumeric characters
- Wide variety of helpful functions already available in the standard software
- Can be directly connected to the control panel or computer
- Option to create application-specific software

### Matching system components

#### **IQZ-HH27-CHARGER1**

Docking station for IQT1-HH27 and IPT-HH27

#### **IQZ-HH27-BAT**

Lithium-polymer battery for IQT1-HH27 and IPT-HH27

### Dimensions

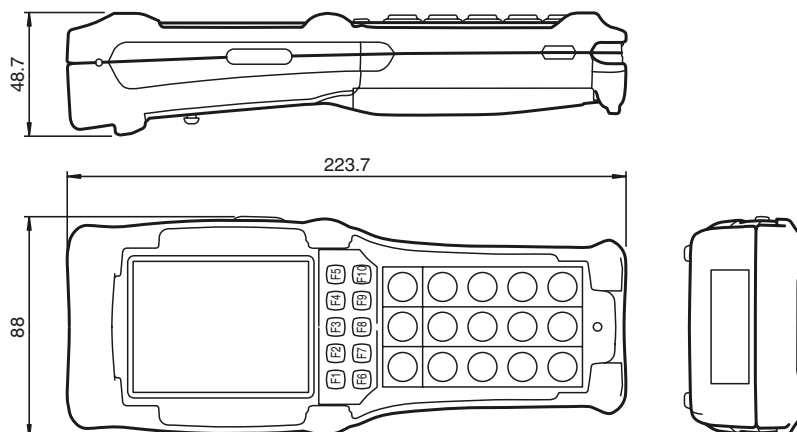

### Technical data

#### General specifications

Description	Handheld with integrated LF read/write device, touch screen, WLAN, Bluetooth, Windows Embedded CE 6.0
Operating frequency	125 kHz

#### Nominal ratings

Processor	Marvell PXA 166 XScale Processor
Clock pulse frequency	800 MHz
Memory	512 MB Flash ROM 256 MB RAM Micro SD card, 1 GB

#### Indicators/operating means

Display	TFT color display with LED backlight, 3.5" Resolution 240 x 320 pixels
Keyboard	Keypad for entering alphanumeric characters
LED green	Device on
Key	Programmable function keys

#### Electrical specifications

Battery type	Lithium polymer battery: 7.4 V; 2200 mAh
Supply	Via docking station or from inserted Li polymer battery

#### Interface

Interface type	Physical: USB connection and Ethernet connection via charger (accessories) Radio connection: WLAN IEEE 802.11 a/b/g, Bluetooth 2.0 + EDR
----------------	---

#### Directive conformity

Radio and telecommunication terminal equipment	
Directive 2014/53/EU	EN 301489-1:2011 V1.9.2, EN 301489-3:2013 V1.6.1, EN 300330-2:2015 V1.6.1, EN 60950-1:2006

#### Standard conformity

Electromagnetic compatibility	EN 61000-6-2:2005, EN 61000-6-4:2006
Degree of protection	EN 60529
RFID	ISO/IEC 15693-2:2006 , ISO/IEC 15693-3:2009 , ISO/IEC 18000-3:2010

#### Ambient conditions

Ambient temperature	0 ... 45 °C (32 ... 113 °F)
Storage temperature	-20 ... 70 °C (-4 ... 158 °F)

#### Mechanical specifications

Degree of protection	IP43
Material	
Housing	Plastic ABS
Mass	approx. 520 g
Dimensions	224 mm x 88 mm x 49 mm
Note	Li polymer battery included in scope of delivery Docking station and charger not included in scope of delivery

#### Approvals and certificates

CE conformity	CE
---------------	----