

Model number

VBA-4E3A-G20-ZEL/E2L-P5

G20 module

4 inputs/3 outputs

Features

- A/B slave with extended addressing possibility for up to 62 slaves
- Inputs for 3-wire sensors
- Power supply of the inputs and outputs from the external auxiliary voltage
- Communication monitoring
- Function display for bus, external auxiliary voltage, in- and outputs
- Cable piercing method with gold plated contact pins
- M12 connection, e.g., suitable for Lenze Smart Motor drives and SEW MOVI-SWITCH

Dimensions

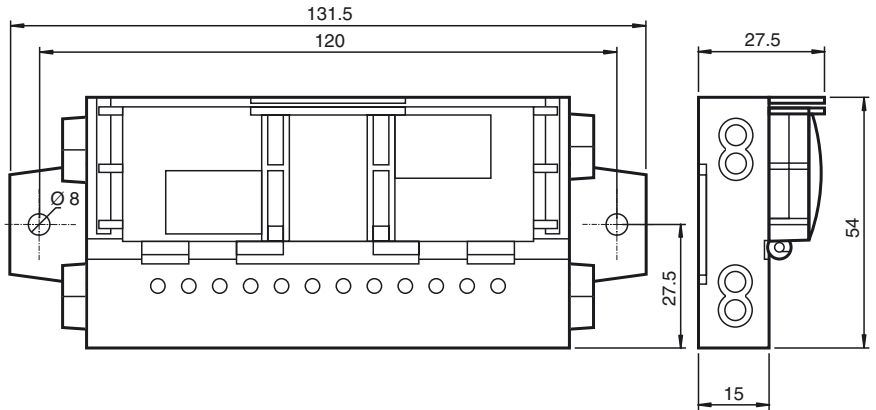

Electrical connection

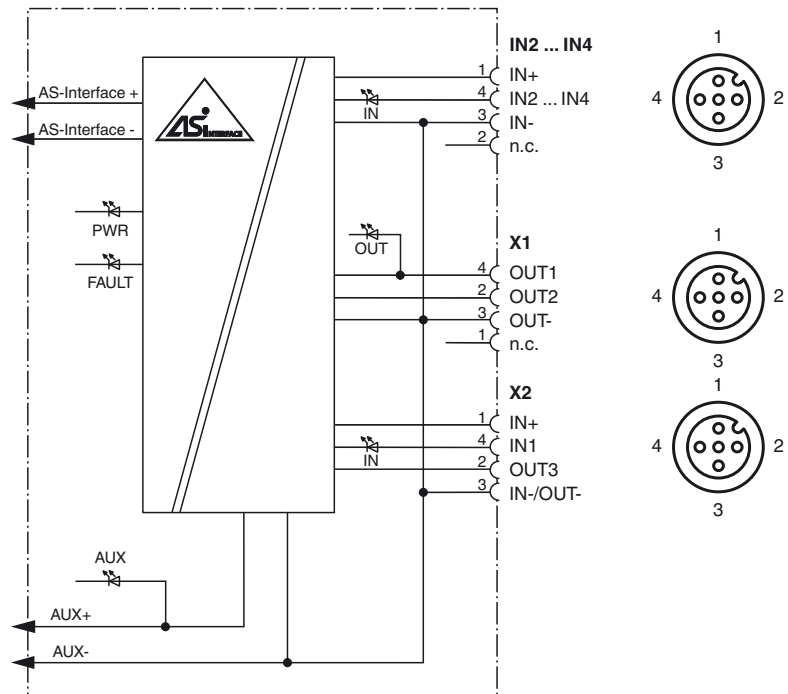

Indicating / Operating means

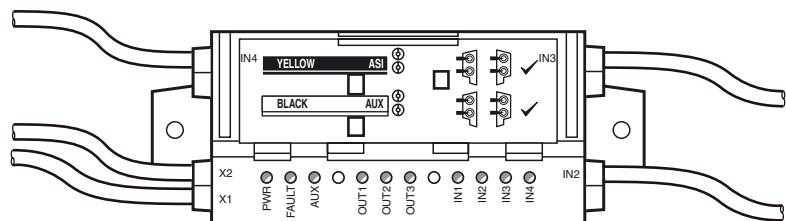

Release date: 2019-01-11 08:21 Date of issue: 2019-01-22 289502_eng.xml

Technical data**General specifications**

Slave type	A/B slave
AS-Interface specification	V3.0
Required master specification	≥ V2.1
UL File Number	E223772 "For use in NFPA 79 Applications only"
MTBF	110 a

Indicators/operating means

LED FAULT	error display; LED red red: communication error or address is 0 red flashing: overload of sensor power supply or overload of outputs or external auxiliary voltage U_{AUX} missing
LED PWR	AS-Interface voltage; green LED green: voltage OK flashing green: address 0 or overload of sensor power supply or overload of outputs or external auxiliary voltage U_{AUX} missing
LED AUX	ext. auxiliary voltage U_{AUX} ; dual LED green/red green: voltage OK red: reverse voltage
LED IN	switching state (input); 4 LED yellow
LED OUT	Switching state (output); 3 LED yellow

Electrical specifications

Auxiliary voltage (output)	U_{AUX}	20 ... 30 V DC PELV
Rated operating voltage	U_e	26.5 ... 31.6 V from AS-Interface
Rated operating current	I_e	≤ 35 mA

Input

Number/Type	4 Inputs for 3-wire sensors (PNP), DC
Supply	from external auxiliary voltage U_{AUX}
Current loading capacity	500 mA, overload and short-circuit protected
Input current	≤ 8 mA (limited internally)
Switching point	according to DIN EN 61131-2 0 (undamped) ≤ 0.5 mA 1 (damped) ≥ 2.0 mA
Signal delay	< 1 ms (input/AS-Interface)

Output

Number/Type	3 electronic outputs, PNP, overload and short-circuit proof
Supply	from external auxiliary voltage U_{AUX}
Current	2 A per output TB ≤ 40 °C: 6 A total TB ≤ 60 °C: OUT1+OUT2 max. 3 A, OUT3 max. 2 A
Voltage	≥ (U_{AUX} - 0.5 V)

Directive conformity

Electromagnetic compatibility	
Directive 2014/30/EU	EN 62026-2:2013

Standard conformity

Degree of protection	EN 60529:2000
Fieldbus standard	EN 62026-2:2013
Input	EN 61131-2:2007
Emitted interference	EN 61000-6-4:2007
AS-Interface	EN 62026-2:2013
Noise immunity	EN 61000-6-2:2005, EN 61326-1:2006, EN 62026-2:2013

Programming instructions

Profile	S-7.A.E
IO code	7
ID code	A
ID1 code	7
ID2 code	E

Data bits (function via AS-Interface)	input	output
D0	IN1	OUT1
D1	IN2	OUT2
D2	IN3	OUT3
D3	IN4	-

Parameter bits (programmable via AS-i) function

P0	Communication monitoring P0 = 0 monitoring = off, the outputs maintain the status if communication fails P0 = 1 monitoring = on, i.e. if communication fails, the outputs are deenergised (default settings)
P1	Input filter P1 = 0 input filter on, pulse suppression ≤ 2 ms P1 = 1 input filter off (default settings)
P2	Synchronous mode P2 = 0 synchronous mode on P2 = 1 synchronous mode off (default settings)

Ambient conditions

Ambient temperature	-25 ... 60 °C (-13 ... 140 °F)
Storage temperature	-25 ... 85 °C (-13 ... 185 °F)

Mechanical specifications**Function**

The AS-Interface I/O module VBA-4E3A-G20-ZEL/E2L-P* is a field module with 4 inputs for 3-wire sensors and 3 electronic outputs. The outputs are overload and short-circuit protected.

The compact housing can be installed directly in support profiles or conduits. The connection to the AS-Interface network and power supply is made using the AS-Interface flat cable and insulation piercing technology. The pivoted flat cable guide is secured using a snap-fit. No tools are required. The inputs and outputs are connected via cable outputs with M12 round plug connectors. Power for the inputs and outputs is provided by the external auxiliary voltage U_{AUX} .

The current switching state of the inputs and outputs is indicated by the IN and OUT LEDs. The PWR and FAULT LEDs indicate the status of the AS-Interface (normal operation, communication error, peripheral fault, address 0). The AUX LED indicates the external power supply.

Notes:

The communication monitor of the module deactivates the outputs if the AS-Interface does not communicate with the module for more than 40 ms.

A signal indicating an overload of the outputs or the input supply or the absence of the external auxiliary voltage is also transmitted to the AS-Interface master via the 'peripheral fault' function. Communication via the AS-Interface continues.

Accessories**VBP-HH1-V3.0-KIT**

AS-Interface Handheld with accessory

VAZ-PK/G20-1M-V1-G

Adapter cable G20 module/hand-held programming device

VAZ-G20-MH

Mounting aid

Degree of protection	IP54 according to EN 60529
Connection	AS-Interface, AUX: Insulation piercing technology Yellow flat cable/black flat cable Inputs/outputs: M12 round plug connector in accordance with EN 61076-2-101 Inputs: LF type (4-pin, bushing contacts, screw lock, A-coded) Matching connector: LM type or similar Outputs: LF type (4-pin, bushing contacts, screw lock, A-coded) Matching connector: LM type or similar
Mass	260 g
Mounting	2 clips with Ø 8 mm drill hole
Cable length	2 m
Note	The flat cable routing is designed for 100 actuation cycles

Release date: 2019-01-11 08:21 Date of issue: 2019-01-22 289502_eng.xml

Refer to "General Notes Relating to Pepperl+Fuchs Product Information".

Pepperl+Fuchs Group
www.pepperl-fuchs.com

USA: +1 330 486 0001
fa-info@us.pepperl-fuchs.com

Germany: +49 621 776 4411
fa-info@de.pepperl-fuchs.com

Singapore: +65 6779 9091
fa-info@sg.pepperl-fuchs.com