



Model number

PXV100A-F200-B28-V1D

Read head for incident light positioning system

Features

- SIL 3 (EN 61508)
- Category 4 PL e (EN ISO 13849)
- PROFINET interface
- PROFIsafe interface
- Safe, non-contact positioning on Data Matrix code tape
- Traverse distance up to 100 km
- Mechanically rugged: no wearing parts, long operating life, maintenance-free

Diagramms

Position Data

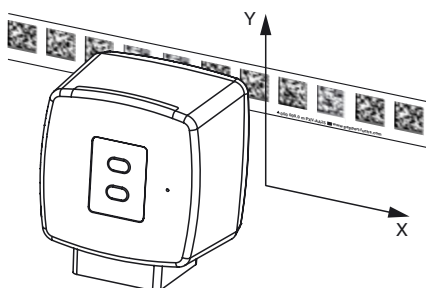

System components

PXV*-AA25-*

Data Matrix code tape

Technical data

General specifications

Passage speed v	≤ 8 m/s
Measuring range	max. 100000 m
Light type	Integrated LED lightning (red/blue)
Read distance	100 mm
Depth of focus	± 30 mm
Observation window	typ. 120 mm x 80 mm
Ambient light limit	30000 Lux
Accuracy	
Non safety-related X	± 0.2 mm
Safety-related X	See the original instructions

Nominal ratings

Camera	
Type	CMOS , Global shutter
Processor	
Clock pulse frequency	600 MHz
Speed of computation	4800 MIPS

Functional safety related parameters

Safety Integrity Level (SIL)	SIL 3
Performance level (PL)	PL e
Category	Cat. 4
Reaction time	165 ms
MTTF	41.66 a
MTTF _d	104.74 a
Mission Time (T _M)	20 a
PFH	1.09 E-8 typ.

Indicators/operating means

LED indication	7 LEDs (communication, status messages)
----------------	---

Electrical specifications

Operating voltage U _B	20 ... 30 V DC , PELV
No-load supply current I ₀	max. 300 mA
Power consumption P ₀	6 W

Interface

Interface type	100 BASE-TX
Protocol	PROFINET IO Real-Time (RT) Conformance class B
Transfer rate	100 MBit/s

Conformity

Fieldbus standard	PROFIsafe in accordance with IEC 61784-3-3; profile 2.4
Functional safety	EN ISO 13849-1:2015 ; EN 61508:2010 part 1-7 ; EN 62061:2005 + AC:2010 + A1:2013 + A2:2015
Shock resistance	EN 60068-2-27:2009
Vibration resistance	EN 60068-2-6:2008
Emitted interference	EN 61000-6-4:2007+A1:2011
Noise immunity	EN 61000-6-7:2015
Photobiological safety	risk group 2 according IEC 62471

Ambient conditions

Operating temperature	0 ... 45 °C (32 ... 113 °F) , -20 ... 45 °C (-4 ... 113 °F) (noncondensing; prevent icing on the lens!)
Storage temperature	-40 ... 85 °C (-40 ... 185 °F)
Relative humidity	90 % , noncondensing
Altitude	≤ 2000 m above MSL

Mechanical specifications

Connection type	8-pin, M12x1 connector, standard 4-pin, M12x1 socket, D-coded (LAN) 4-pin, M12x1 socket, D-coded (LAN)
Housing width	70 mm
Housing height	70 mm
Housing depth	50 mm
Degree of protection	IP67
Material	
Housing	PC/ABS
Mass	approx. 200 g

Approvals and certificates

CE conformity	CE
CCC approval	CCC approval / marking not required for products rated ≤36 V
TÜV approval	TÜV Rheinland 01/205/5669.00/18

Dimensions

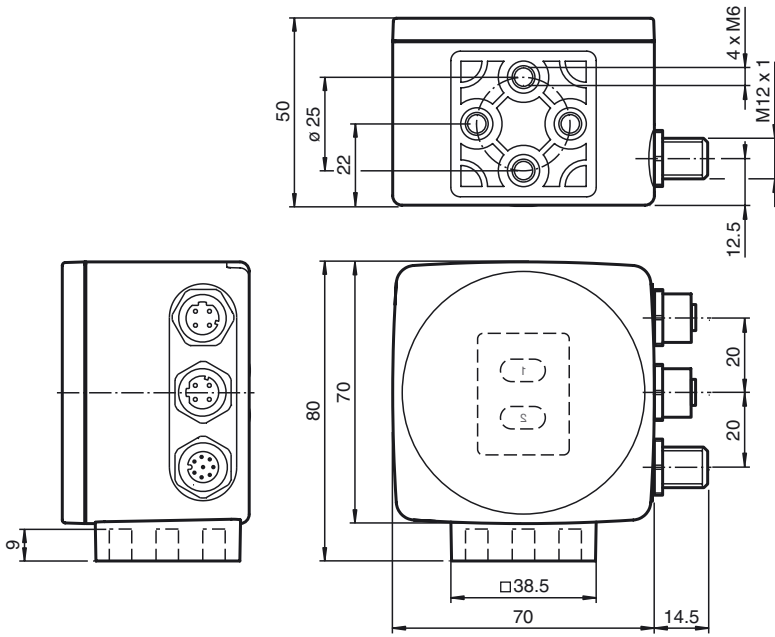

Additional information

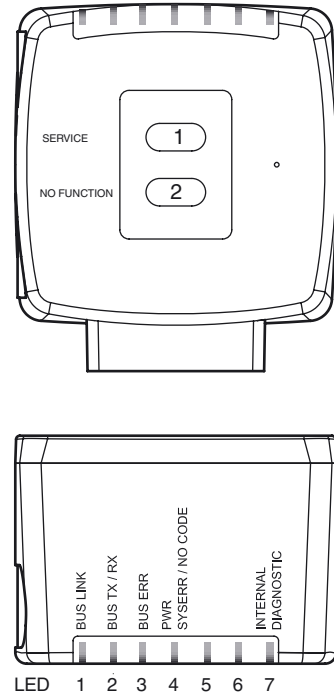

Electrical connection

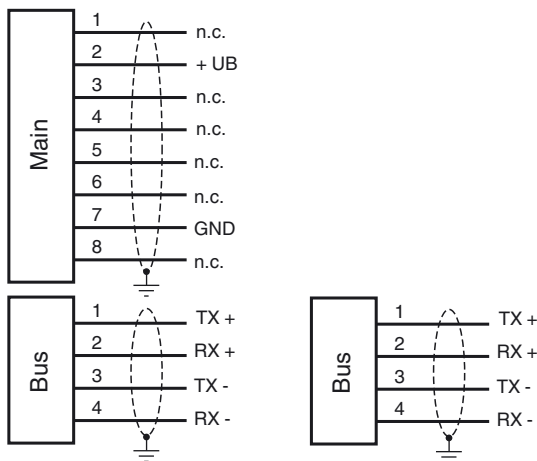

Pinout

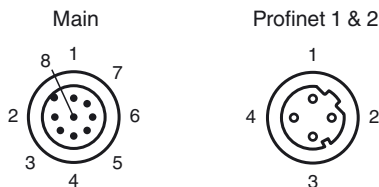

Accessories

PGV25M-CD100-CLEAR

Protective laminate for PGV code tape

PCV-AG100

Alignment guide for PCV100-* read head

PCV-SC12

Grounding clip for PCV system

PCV-SC12A

Grounding clip for PCV system

PCV-LM25

Marker head for 25 mm code tape

PCV-MB1

Mounting bracket for PCV* read head

V1SD-G-2M-PUR-ABG-V1SD-G

Ethernet bus cable, M12 to M12, PUR cable 4-pin, CAT5e

V1SD-G-5M-PUR-ABG-V1SD-G

Ethernet bus cable, M12 to M12, PUR cable 4-pin, CAT5e

V1SD-G-10M-PUR-ABG-V1SD-G

Ethernet bus cable, M12 to M12, PUR cable 4-pin, CAT5e

V1SD-G-5M-PUR-ABG-V45-G

Connection cable, M12 to RJ-45, PUR cable 4-pin, CAT5e

V1SD-G-10M-PUR-ABG-V45-G

Connection cable, M12 to RJ-45, PUR cable 4-pin, CAT5e

V1SD-G-30M-PUR-ABG-V45-G

Connection cable, M12 to RJ-45, PUR cable 4-pin, CAT5e

V19-G-ABG-PG9

Release date: 2018-12-19 16:01 Date of issue: 2018-12-19 296169_eng.xml

Accessories

Female connector, M12, 8-pin, shielded, field attachable

V19-G-ABG-PG9-FE

Female connector, M12, 8-pin, shielded, field attachable

V19-G-2M-PUR-ABG

Female cordset, M12, 8-pin, shielded, PUR cable

V19-G-5M-PUR-ABG

Female cordset, M12, 8-pin, shielded, PUR cable

V19-G-10M-PUR-ABG

Female cordset, M12, 8-pin, shielded, PUR cable

Additional Information

Function

The reader forms part of the positioning system in the Pepperl+Fuchs incident light process. The reader's features include a camera module and internal illumination unit, enabling it to detect position markers printed onto an adhesive, colored code tape in the form of Data Matrix codes. The code tape is generally mounted stationary on a fixed part of the plant, e.g., elevator shaft, monorail conveyor mounting rails, etc., and the reader is mounted parallel on the moving "vehicle," e.g., elevator car, monorail conveyor chassis, etc.

The positioning system issues position values that achieve the reliability required by SIL 3 and PL e, provided that the device is properly integrated into the plant according to the specifications given in the original instructions.

Mounting and Commissioning

Mount the reader such that the optical surface of the device captures the optimal reading distance to the Data Matrix code tape (see "Technical Data"). The stability of the mounting and the manner in which the vehicle is guided ensure that the reader is not operated outside of its depth of focus range. The code tape must not leave the maximum reading window for the reader during this process.

Displays and Operating Elements

The reader is equipped with the following indicator LEDs for carrying out visual function checks and quick diagnostics:

LEDs

LED	Color	Label	Meaning
1	Green	BUS LINK	PROFINET connection activated
2	Yellow	BUS TX/RX	Data transfer
3	Red	BUS ERR	PROFINET communication error
4	Red/green	PWR SYSERR/NO CODE	Code detected/not detected, error
5	-	-	No function
6	-	-	No function
7	Red/green/ yellow	INTERNAL DIAGNOSTIC	Internal diagnostics

The SERVICE button on the back of the device is used for internal service purposes.