

Features

- 1 digital output, 2 digital inputs
- Inputs and output Ex ia
- Installation in suitable enclosures in Zone 1
- Module can be exchanged under voltage (hot swap)
- Positive or negative logic selectable
- Simulation mode for service operations (forcing)
- Line fault detection (LFD)
- Permanently self-monitoring
- Output with watchdog

Function

The digital output features 1 output with 2 feedback inputs. The device can be used to switch solenoids, sounders, or indicators (without line fault detection) in the field. Furthermore, the device accepts digital input signals of NAMUR sensors or mechanical contacts from the field. Open and short-circuit line faults are detected. The intrinsically safe inputs and the output are galvanically isolated from the bus and the power supply.

Assembly

Front view

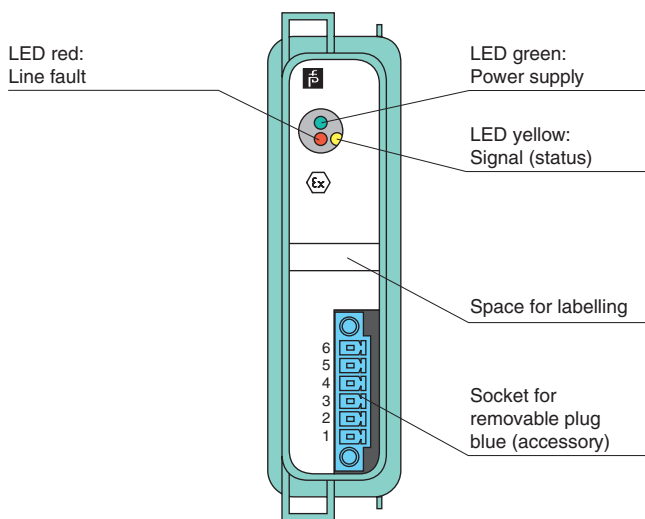

Connection

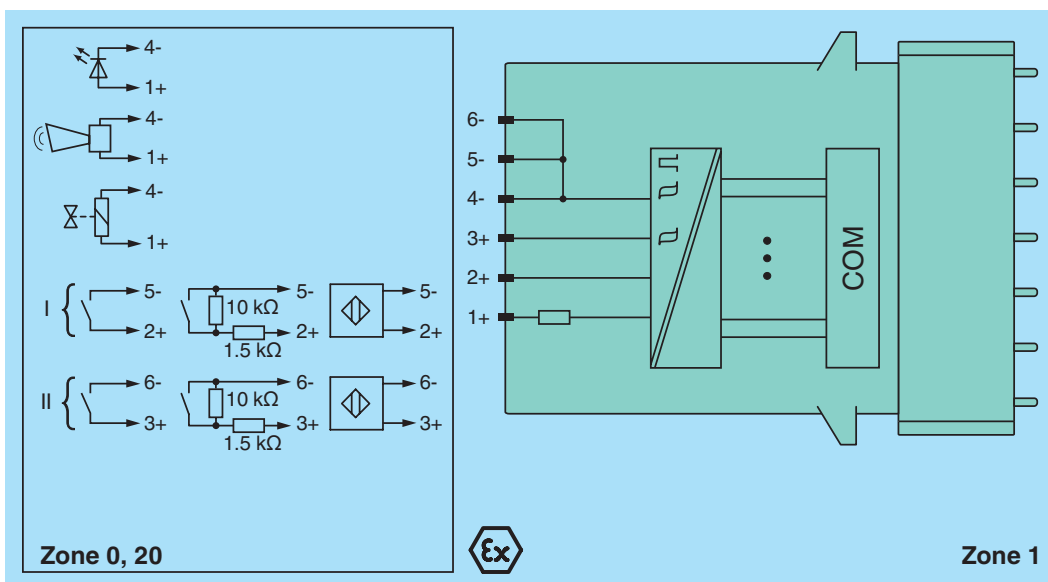

Release date 2018-09-13 15:53 Date of issue 2018-09-13 302469_eng.xml

Refer to "General Notes Relating to Pepperl+Fuchs Product Information".

Slots		
Occupied slots		1
Supply		
Connection		backplane bus
Rated voltage	U_r	12 V DC , only in connection with the power supplies FB92**
Power dissipation		1.4 W
Power consumption		1.7 W
Internal bus		
Connection		backplane bus
Interface		manufacturer-specific bus to standard com unit
Digital input		
Number of channels		2
Sensor interface		
Connection		NAMUR sensor
Connection [2]		volt-free contact
Connection [3]		active binary signal 24 V DC
Connection		channel I: 2+, 5-; channel II: 3+, 6-
Rated values		acc. to EN 60947-5-6 (NAMUR)
Switching point/switching hysteresis		1.2 ... 2.1 mA / ± 0.2 mA
Internal resistor	R_i	1 k Ω
Line fault detection		
Connection		can be switched on/off for each channel via configuration tool mechanical switch with additional resistors (see connection diagram) proximity switches without additional wiring
Short-circuit		< 360 Ω
Open-circuit		< 0.35 mA
Minimum pulse duration		1 ms
Digital output		
Number of channels		1
Suitable field devices		
Field device		Solenoid Valve
Field device [2]		audible alarm
Field device [3]		visual alarm
Connection		channel I: 1+, 4-
Open loop voltage	U_s	24 V
Current limit	I_{max}	50 mA
Internal resistor	R_i	360 Ω
Line fault detection		
		can be switched on/off for each channel via configuration tool , also when turned off (every 2.5 s the valve is turned on for 2 ms)
Short-circuit		< 145 Ω
Open-circuit		> 2 k Ω
Response time		20 ms (depending on bus cycle time)
Watchdog		within 0.5 s the device goes in safe state, e.g. after loss of communication
Indicators/settings		
LED indication		LED green: supply LED red: output line fault LED yellow: status output
Coding		optional mechanical coding via front socket
Directive conformity		
Electromagnetic compatibility		
Directive 2014/30/EU		EN 61326-1
Conformity		
Electromagnetic compatibility		
Degree of protection		NE 21
Environmental test		IEC 60529
Shock resistance		EN 60068-2-14
Vibration resistance		EN 60068-2-27
Damaging gas		EN 60068-2-6
Relative humidity		EN 60068-2-42
Relative humidity		EN 60068-2-56
Ambient conditions		
Ambient temperature		-20 ... 60 °C (-4 ... 140 °F)
Storage temperature		-25 ... 85 °C (-13 ... 185 °F)
Relative humidity		95 % non-condensing
Shock resistance		shock type I, shock duration 11 ms, shock amplitude 15 g, number of shocks 18

Release date 2018-09-13 15:53 Date of issue 2018-09-13 302469_eng.xml

Refer to "General Notes Relating to Pepperl+Fuchs Product Information".

Vibration resistance	frequency range 10 ... 150 Hz; transition frequency: 57.56 Hz, amplitude/acceleration ± 0.075 mm/1 g; 10 cycles frequency range 5 ... 100 Hz; transition frequency: 13.2 Hz amplitude/acceleration ± 1 mm/0.7 g; 90 minutes at each resonance
Damaging gas	designed for operation in environmental conditions acc. to ISA-S71.04-1985, severity level G3
Mechanical specifications	
Degree of protection	IP20 (module) , a separate housing is required acc. to the system description
Connection	removable front connector with screw flange (accessory) wiring connection via spring terminals (0.14 ... 1.5 mm ²) or screw terminals (0.08 ... 1.5 mm ²)
Mass	approx. 350 g
Dimensions	28 x 107 x 132 mm (1.1 x 4.2 x 5.2 inch)
Data for application in connection with hazardous areas	
EU-Type Examination Certificate	PTB 97 ATEX 1074 U
Marking	 II 2(1) G Ex d [ia Ga] IIC Gb
Input	
Voltage	U _o 14.1 V
Current	I _o 16 mA
Power	P _o 55 mW (linear characteristic)
Internal capacitance	C _i 1.65 nF
Output	
Voltage	U _o 27.83 V
Current	I _o 91.7 mA
Power	P _o 636 mW
Internal capacitance	C _i 1.65 nF
Galvanic isolation	
Input/power supply, internal bus	safe electrical isolation acc. to EN 60079-11, voltage peak value 375 V
Output/power supply, internal bus	safe electrical isolation acc. to EN 60079-11, voltage peak value 375 V
Directive conformity	
Directive 2014/34/EU	EN 60079-0:2009 EN 60079-1:2007 EN 60079-11:2007 EN 60079-26:2007 EN 61241-11:2006
International approvals	
ATEX approval	PTB 97 ATEX 1075 ; PTB 97 ATEX 1074 U
EAC approval	Russia: RU C-IT.MIII06.B.00129
Marine approval	
Lloyd Register	15/20021
DNV GL Marine	TAA0000034
American Bureau of Shipping	T1450280/UN
Bureau Veritas Marine	22449/B0 BV
General information	
System information	The module has to be mounted in appropriate backplanes and housings (FB92**) in Zone 1, 2, 21, 22 or outside hazardous areas (gas or dust). Here, observe the corresponding EC-type examination certificate.
Supplementary information	EC-Type Examination Certificate, Statement of Conformity, Declaration of Conformity, Attestation of Conformity and instructions have to be observed where applicable. For information see www.pepperl-fuchs.com .

Release date 2018-09-13 15:53 Date of issue 2018-09-13 302469_eng.xml

Output data

Load calculation

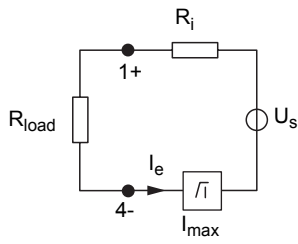

R_{load} = Field loop resistance
 $U_e = U_s - R_i \times I_e$
 $I_e = U_s / (R_i + R_{load})$

Output characteristics

