

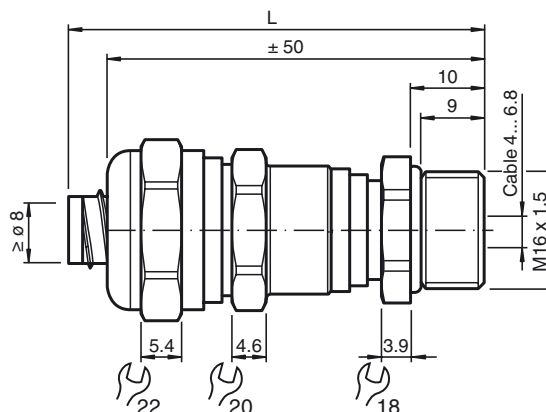

Dimensions



Model Number

CP-CGL-MS-5/16-M16 5pcs

Cable gland M16 for cable diameter 4 ... 6.8 mm and 5/16" flexible metal conduit

Features

- Suitable for 5/16" flexible metal conduit

Function

The cable gland is used in conjunction with a suitable flexible conduit and a suitable sensor adapter to form a cable protection system for sensors. The purpose of this system is to protect the sensor wiring in harsh environments.

Matching system components

CP-CDT-MS-5/16-10M

5/6" flexible metal conduit 10 m

CP-ADP-MS-5/16-M18 5pcs

Sensor adapter for M18 sensors and 5/6" flexible metal conduit

CP-ADP-MS-5/16-M30 5pcs

Sensor adapter for M39 sensors and 5/6" flexible metal conduit

Technical data

Mechanical specifications

Clamping range (D)	
Seal insert	outer seal: for cable diameter 6 ... 6.8 mm outer seal + inner seal: for cable diameter 4 ... 6 mm
Thread type	metric
Thread size	M16 x 1.5
Degree of protection	IP65
Material	
Cable gland	brass, nickel-plated
Seal	Seal two-piece , synthetic rubber EDPM V0
Clamping ring	brass, nickel-plated
O-Ring	NBR
Mass	58 g

General information

Supplementary information	observe mounting instructions
---------------------------	-------------------------------