

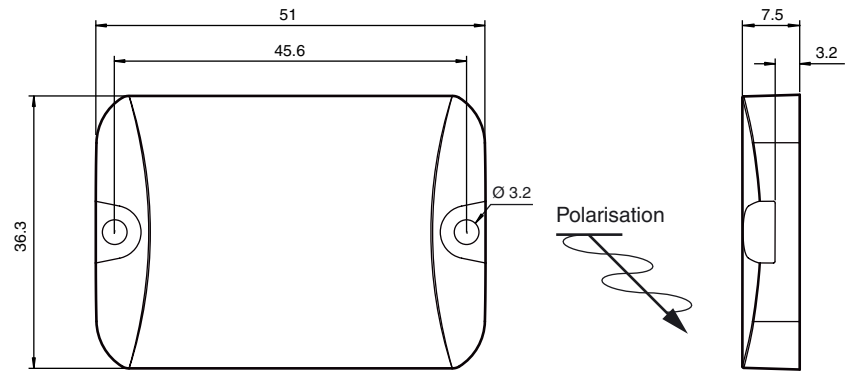

Dimensions



Model Number

IUC76-F157-T17-M-FR2

Data carrier for standard applications

Features

- Operating frequency 902 ... 928 MHz
- Complies with EPC Gen2 (ISO/IEC 18000-63)
- Sturdy housing, suitable for rough industrial use
- Optimized for mounting on metal
- For general purpose applications

Technical data

General specifications

Operating frequency	902 ... 928 MHz
Polarization	linear

Memory

Chip Type	Higgs-3 (Alien)
Memory Bank 00 (Reserved)	64 Bit
Memory Bank 01 (EPC/Ull)	96 ... 480 Bit
Memory Bank 10 (TID)	64 Bit
Memory Bank 11 (User memory)	512 Bit
Read cycles	unlimited
Write cycles	100000
Data retention period	50 years @ 77 °C (170.6 °F)

Directive conformity

Electromagnetic compatibility	
R&TTE Directive 1995/5/EC	EN 302208-2:2011 V1.4.1

Standard conformity

Electromagnetic compatibility	EN 302208-2:2011 V1.4.1
Degree of protection	EN 60529:2000
RFID	ISO/IEC 18000-63:2013

Ambient conditions

Ambient temperature	-40 ... 85 °C (-40 ... 185 °F)
Storage temperature	-40 ... 150 °C (-40 ... 302 °F) 10 minutes at 250 °C (dry heat) for 250 test cycles, 1 hour cooling
Shock and impact resistance	3 ft (1m) to concrete up to 200 cycles

Mechanical specifications

Degree of protection	IP68
Material	
Housing	PA 6
Installation	
On metal	yes
Mass	26 g
Construction type	Rectangular type

Notes

High temperatures will cause the housing to expand.
If the housing is assembled under mechanical stress, the resulting pressure may damage the tag.
Install the tag loosely to allow for expansion due to high temperatures.