



**Model Number**

**Montageplatte LT**

Mounting plate for sensors in the LT and FLT series

**Features**

- Mounting plate for the installation of sensors from LT or LTK series in suspended ceilings
- Front panel specially toughened and crack resistant
- Carrying frame for sensor with adjustable 4-point fixture
- Precise sensor orientation using additional adjustment screws

**Dimensions**

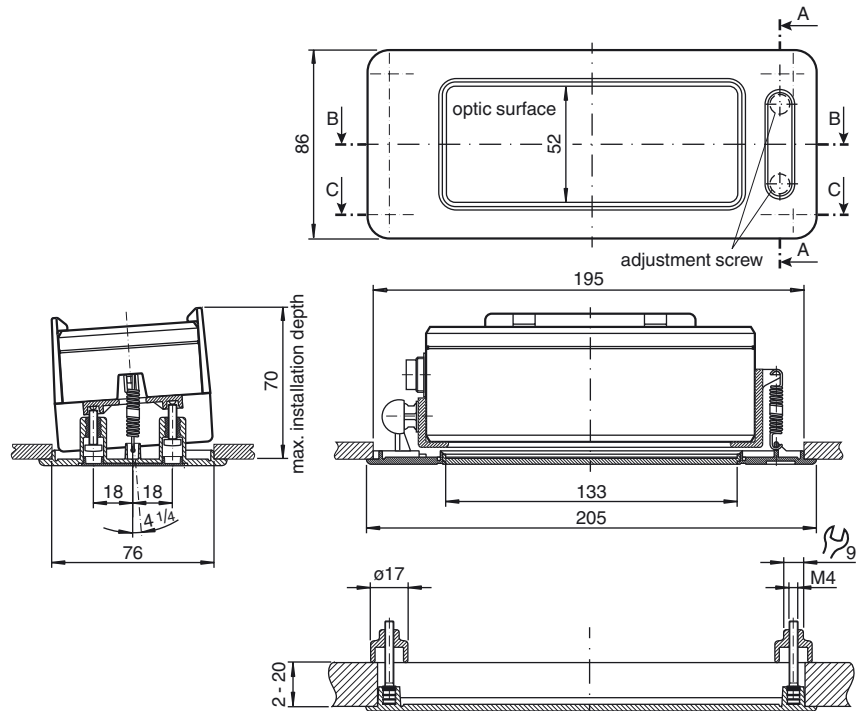

**Technical data**

**Mechanical specifications**

Material	Plastic ABS
Optical face	Blue Plexiglas
Mass	approx. 155 g
<b>Suitable series</b>	
Series	LT , LTK

Used to install sensors in suspended ceilings. The sensor can be rotated after it is installed by two screws accessible from the front. This makes it possible to adjust the recording range accurately. After the setting has been made, the adjustment screws can be hidden behind the accompanying cover flap.

Release date: 2015-02-27 08:53 Date of issue: 2015-02-27 414076\_eng.xml