



Model Number

MPZB06

Ball and Swivel Mounting Bracket

Features

- Mounting bracket
- Adjustable Bracket

Function

The basic ball and swivel mounting bracket (360° swivel, 10° tilt) consists of two plastic brackets and the spherical plastic swivel nut. The swivel nut has M30 threading for direct installation on the sensor's base, including on quick disconnect versions. The bracket can be directly mounted to a surface, or the MPZB07 mounting plate may be used.

Dimensions

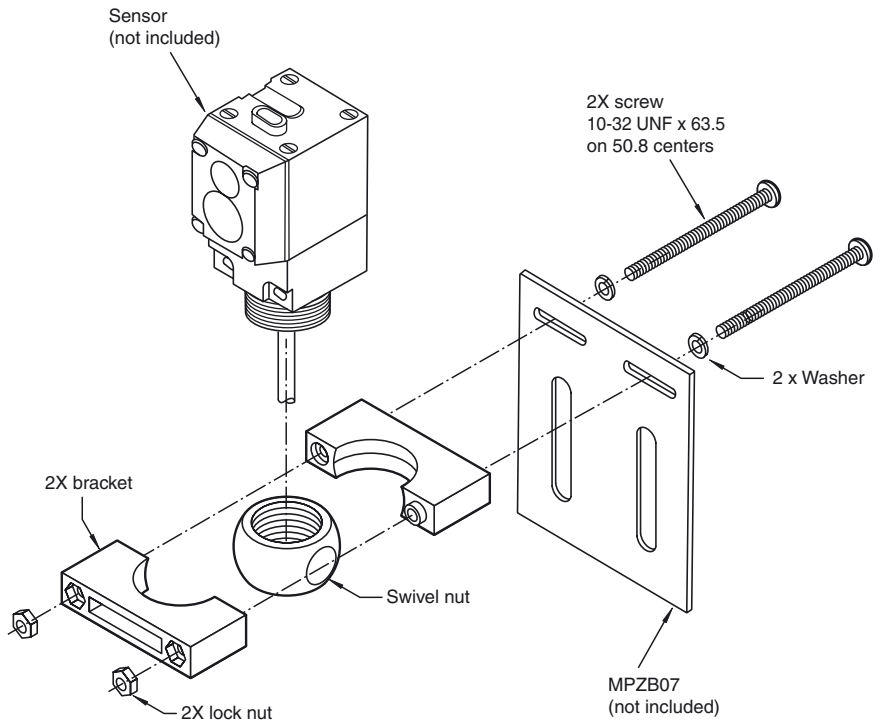

Technical data

Mechanical specifications

Material	plastic
Mass	approx. 830 g
Suitable series	
Series	Series 61 , MP Series

Release date: 2011-08-31 22:28 Date of issue: 2011-08-31 454518_eng.xml

Subject to modifications without notice

Pepperl+Fuchs Group
www.pepperl-fuchs.com

USA: +1 330 486 0001
fa-info@us.pepperl-fuchs.com

Germany: +49 621 776-4411
fa-info@pepperl-fuchs.com

Copyright Pepperl+Fuchs
Singapore: +65 6779 9091
fa-info@sg.pepperl-fuchs.com