



Model Number

ENA36HD-S***-CANopen

Features

- Very small housing
- Up to 31 bit overall resolution
- CANopen interface
- Free of wear magnetic sampling
- High resolution and accuracy
- High climatic resistance

Description

This absolute rotary encoder provides a position value corresponding to the shaft position on its integrated CAN bus interface. The integrated CAN-bus interface supports all CANopen functions.

Thus the following modes can be programmed to either enabled or disabled:

- Polled Mode
- Cyclic Mode
- Sync Mode

Technical Data

General specifications

Detection type	magnetic sampling
Device type	Absolute encoders
Linearity error	$\leq \pm 0.1^\circ$
UL File Number	E223176 "For use in NFPA 79 Applications only", if UL marking is marked on the product.

Functional safety related parameters

MTTF _d	480 a at 40 °C
Mission Time (T _M)	20 a
L ₁₀	10 E+8 revolutions
Diagnostic Coverage (DC)	0 %

Electrical specifications

Operating voltage U _B	9 ... 30 V DC (with galvanic isolation)
Power consumption P ₀	≤ 1.2 W
Time delay before availability t _v	< 250 ms
Output code	binary code
Code course (counting direction)	adjustable

Interface

Interface type	CANopen
Resolution	
Single turn	up to 16 Bit
Multiturn	up to 15 Bit
Overall resolution	up to 31 Bit
Transfer rate	min. 20 kBit/s , max. 1 MBit/s
Cycle time	≥ 1 ms
Standard conformity	DSP 406

Connection

Connector	M12 connector, 5 pin
Cable	$\varnothing 6$ mm, 4 x 2 x 0.14 mm ²

Standard conformity

Degree of protection	DIN EN 60529 , IP68 / IP69K
Climatic testing	DIN EN 60068-2-3, no moisture condensation
Emitted interference	EN 61000-6-4:2007
Noise immunity	EN 61000-6-2:2005
Shock resistance	DIN EN 60068-2-27, 200 g, 11 ms
Vibration resistance	DIN EN 60068-2-6, 30 g, 10 ... 1000 Hz

Ambient conditions

Operating temperature	-40 ... 85 °C (-40 ... 185 °F)
Storage temperature	-40 ... 85 °C (-40 ... 185 °F)
Relative humidity	98 % , no moisture condensation

Mechanical specifications

Material	
Housing	powder coated steel
Flange	Aluminum
Shaft	Stainless steel
Mass	approx. 150 g
Rotational speed	max. 6000 min ⁻¹
Moment of inertia	30 gcm ²
Starting torque	< 5 Ncm
Shaft load	
Axial	180 N
Radial	180 N

Approvals and certificates

UL approval	cULus Listed, General Purpose, Class 2 Power Source , if UL marking is marked on the product.
-------------	---

Dimensions

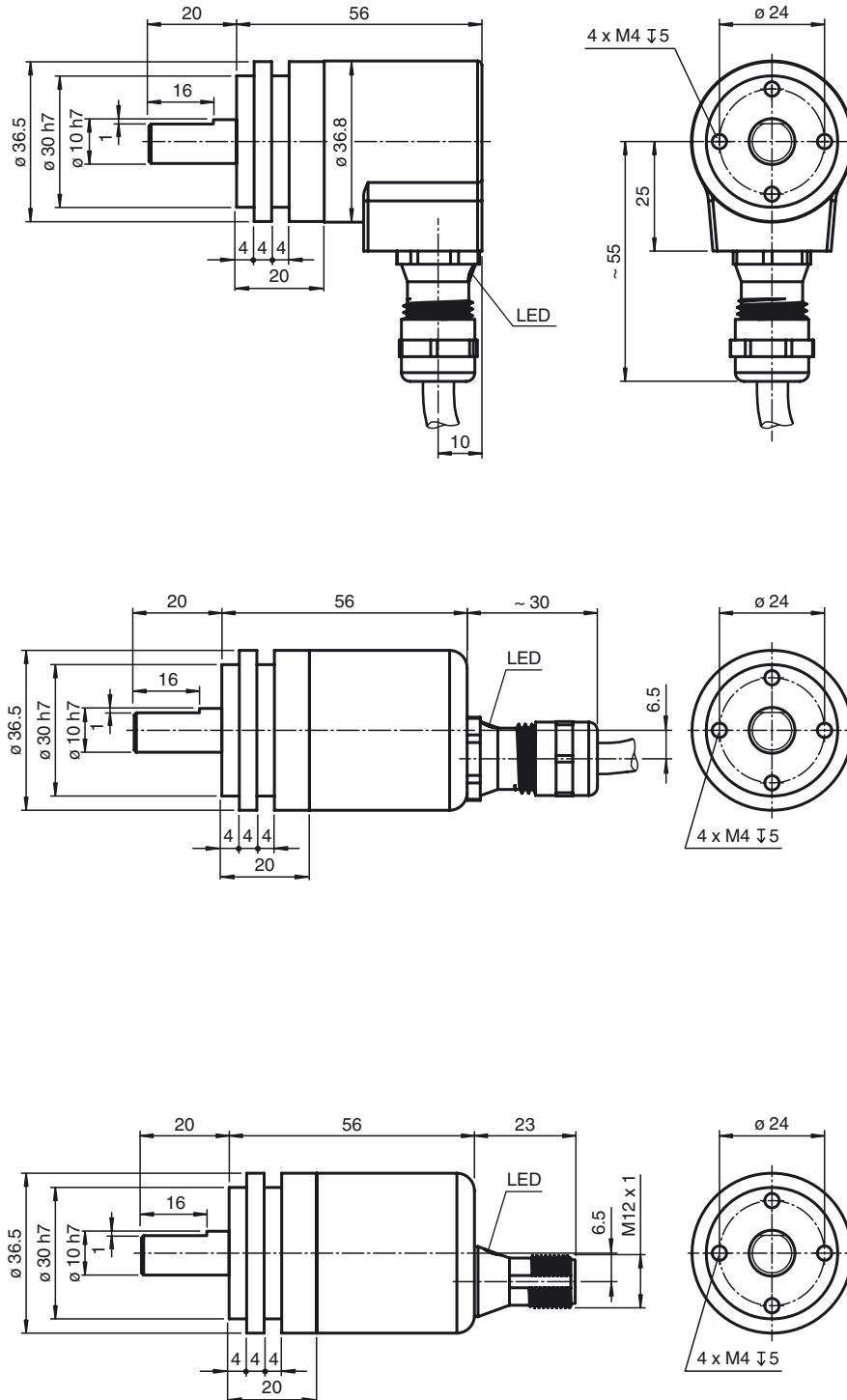

Release date: 2019-01-31 14:20 Date of issue: 2019-01-31 1182422_eng.xml

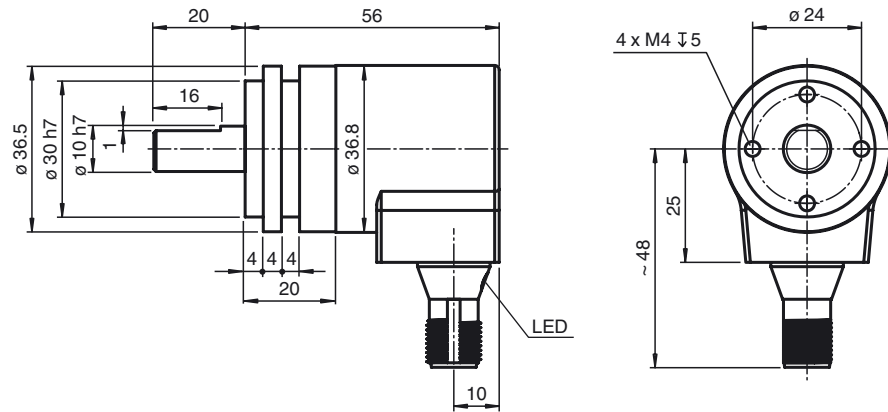

Electrical connection

Signal	Wire end	5-pin, M12 x 1 connector
CAN GND	green	1
+V _S	red	2
GND	yellow	3
CAN-High	white	4
CAN-Low	brown	5
Shielding	Shielding	Housing
Pinout		

Release date: 2019-01-31 14:20 Date of issue: 2019-01-31 1182422_eng.xml

Refer to "General Notes Relating to Pepperl+Fuchs Product Information".

Pepperl+Fuchs Group
www.pepperl-fuchs.com

USA: +1 330 486 0001
fa-info@us.pepperl-fuchs.com

Germany: +49 621 776 1111
fa-info@de.pepperl-fuchs.com

Singapore: +65 6779 9091
fa-info@sg.pepperl-fuchs.com

Indicating elements

LED-indicator with dual color LED

CAN Run (green)	State	Description
Blinking	Pre-Operational	Boot up message is sent, device configuration is possible, device is in CAN state „Pre-Operational“
Single flash	Stopped	The Encoder is in CAN state „Stopped“
On	Operational	The encoder is in CAN state „Operational“
Off		No power supply
Err (red)	State	Description
Off	No error	The Encoder is in operating mode
Flickering	AutoBitrate	Auto baud mode is active and the encoder tries to find within the time out period a valid CAN message for baud rate measurement
Single flash	Warning limit reached	At least one of the error counters of the CAN controller has reached or exceeded the warning level (too many error frames)
Double flash	Error control event	A guard event (NTM slave or NTM master) or a heartbeat event has occurred
On	Bus off	The CAN controller is in stae bus off. No communication possible anymore. Too many error frames in the network.

Programmable CAN operating modes

Mode	Explanation
Polled mode	The connected host requests the current actual position value via a remote transmission request telegram. The absolute encoder reads in the current position, calculates all parameters that have been set and sends back the process actual value through the same CAN identifier.
Cyclic mode	The absolute encoder sends the current actual process value cyclically, without being prompted by the host. The cycle time can be programmed in milliseconds for values between 1 ms and 65536 ms.
Sync mode	After the sync telegram has been received by the host, the absolute encoder sends the current actual process value. If multiple nodes should respond to the sync telegram, the individual nodes report one after the other according to their CAN identifier. There is no programming of an offset time. The sync counter can be programmed so that the rotary encoder does not transmit until after a defined number of sync telegrams.

Programmable rotary encoder parameters

Parameter	Explanation
Operating parameter	The direction of rotation (complement) can be specified by parameter as the operating parameter. This parameter determines the direction of rotation in which the output code will ascend or descend.
Resolution per revolution	The "Resolution" parameter is used to program the rotary encoder so that a desired number of steps can be implemented in reference to one revolution.
Preset value	The preset value is the desired position value that must be achieved for a specific physical setting of the axis. The preset value parameter is used to set the actual position value to the desired actual process value.
Min. and max. limit switch	A total of two positions can be programmed. The absolute encoder sets one bit to high state in the 32 Bit actual process value if a value falls outside the range between these two positions.
Cam	8 freely programmable cams can be set within the overall resolution. This produces the functionality of a mechanical cam shifting mechanism.

Model number

E N A 3 6 H D - S 1 0 S A 9 - - - - B 1 6 - - -

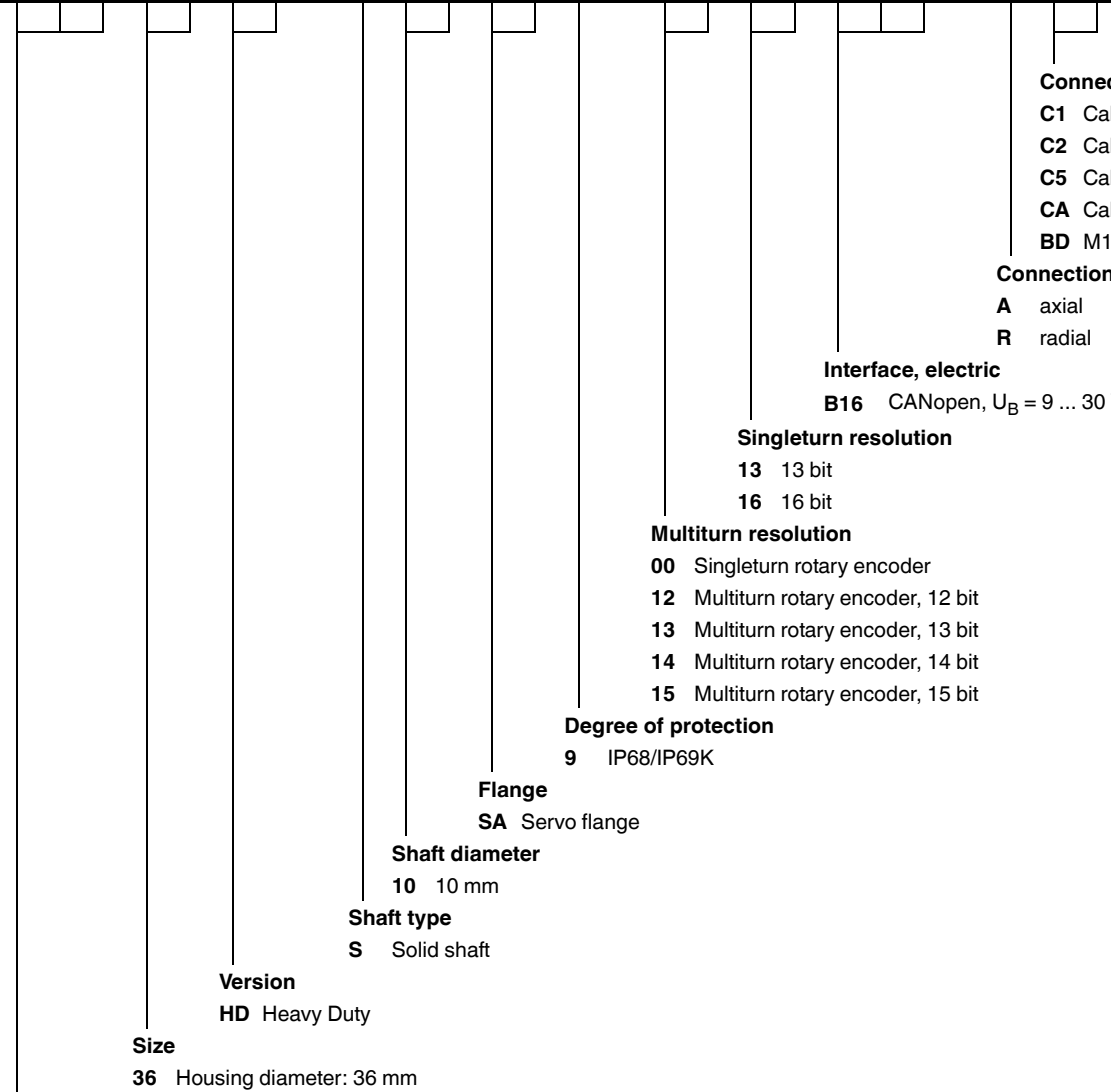

- Connection type**
C1 Cable, 1 m
C2 Cable, 2 m
C5 Cable, 5 m
CA Cable, 10 m
BD M12 device plug, 5-pin
- Connection alignment**
A axial
R radial

- Interface, electric**
B16 CANopen, $U_B = 9 \dots 30 \text{ V}$

- Singleturn resolution**
13 13 bit
16 16 bit

- Multiturn resolution**
00 Singleturn rotary encoder
12 Multiturn rotary encoder, 12 bit
13 Multiturn rotary encoder, 13 bit
14 Multiturn rotary encoder, 14 bit
15 Multiturn rotary encoder, 15 bit

- Degree of protection**
9 IP68/IP69K

- Flange**
SA Servo flange

- Shaft diameter**
10 10 mm

- Shaft type**
S Solid shaft

- Version**
HD Heavy Duty

- Size**
36 Housing diameter: 36 mm

Device type
ENA Absolute rotary encoder

Release date: 2019-01-31 14:20 Date of issue: 2019-01-31 1182422_eng.xml