



### Model Number

ENA58IL-R\*\*\*-J1939

### Features

- Recessed hollow shaft
- Up to 31 bit overall resolution
- CAN bus with SAE J1939 protocol
- Free of wear magnetic sampling
- High resolution and accuracy

### Description

This absolute rotary encoder provides a position value corresponding to the shaft position on its integrated J1939 interface. The rugged miniature encoders are based on magnetic sampling.

## Technical data

### General specifications

Detection type	magnetic sampling
Device type	Absolute encoders
Linearity error	$\leq \pm 0.1^\circ$
UL File Number	E223176 "For use in NFPA 79 Applications only", if UL marking is marked on the product.

### Functional safety related parameters

MTTF <sub>d</sub>	480 a at 40 °C
Mission Time (T <sub>M</sub> )	20 a
L <sub>10</sub>	5 E+8 revolutions at 24/198 N axial/radial shaft load
Diagnostic Coverage (DC)	0 %

### Indicators/operating means

LED green	Operating mode
LED red	wrong baud rate

### Electrical specifications

Operating voltage U <sub>B</sub>	9 ... 30 V DC (with galvanic isolation)
Power consumption P <sub>0</sub>	$\leq 1.2$ W
Time delay before availability t <sub>v</sub>	< 250 ms
Output code	binary code
Code course (counting direction)	adjustable

### Interface

Interface type	J1939
Resolution	
Single turn	up to 16 Bit
Multiturn	up to 15 Bit
Overall resolution	up to 31 Bit
Transfer rate	min. 20 kBit/s , max. 1 MBit/s
Cycle time	$\geq 1$ ms
Standard conformity	ISO 11898

### Connection

Connector	M12 connector, 5 pin
Cable	Ø6 mm, 4 x 2 x 0.14 mm <sup>2</sup>

### Standard conformity

Degree of protection	DIN EN 60529, IP65 or IP67
Climatic testing	DIN EN 60068-2-3, no moisture condensation
Emitted interference	EN 61000-6-4:2007
Noise immunity	EN 61000-6-2:2005
Shock resistance	DIN EN 60068-2-27, 200 g, 6 ms
Vibration resistance	DIN EN 60068-2-6, 20 g, 10 ... 1000 Hz

### Ambient conditions

Operating temperature	cable, flexing: -5 ... 70 °C (23 ... 158 °F), cable, fixed: -30 ... 70 °C (-22 ... 158 °F) connector models: -40 ... 85 °C (-40 ... 185 °F)
Storage temperature	-40 ... 85 °C (-40 ... 185 °F)
Relative humidity	98 % , no moisture condensation

### Mechanical specifications

Material	
Housing	nickel-plated steel , painted
Flange	Aluminum
Shaft	Stainless steel
Mass	approx. 300 g
Rotational speed	max. 12000 min <sup>-1</sup>
Moment of inertia	50 gcm <sup>2</sup>
Starting torque	< 5 Ncm
Shaft load	
Axial	24 N
Radial	198 N
Angle offset	$\pm 0.9^\circ$
Axial offset	$\pm 0.3$ mm static
Radial offset	$\pm 0.5$ mm static

### Approvals and certificates

UL approval	cULus Listed, General Purpose, Class 2 Power Source , if UL marking is marked on the product.
-------------	---

**Dimensions**

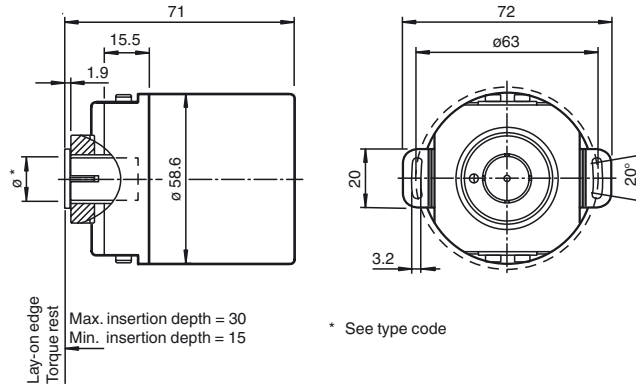

Recessed hollow shaft

**Connections**

Dimensions in mm

**Cable**

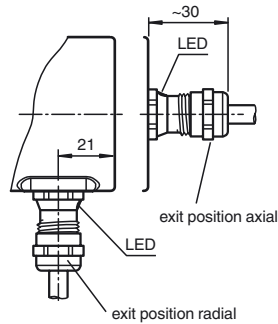

**Connector M12**

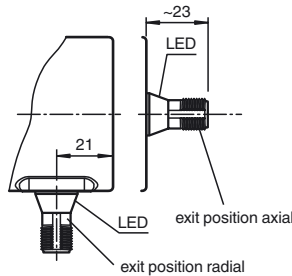

**Electrical connection**

Signal	Wire end	5-pin, M12 x 1 connector
CAN GND	green	1
+V <sub>S</sub>	red	2
GND	yellow	3
CAN-High	white	4
CAN-Low	brown	5
Shielding	Shielding	Housing
Pinout		

**Example of the transmit commands**

Command	Identifier	Data	Comments
Read request Direction	18EA2000	01 EF 00 00 00 00 00 00	
Read request Node	18EA2000	08 EF 00 00 00 00 00 00	
Write Direction	00EF2000	01 01 00 00 00 FF FF FF (CCW increase position)	When you change direction it will give you a different positional value. You will then need to set your preset value.
Write PRESET	00EF2000	04 A8 61 00 00 FF FF FF (value 25.000)	The preset value should be received at positional value 18FFAA20.
Write Save	00EF2000	FA 73 61 76 65 FF FF FF	The settings saved in non-volatile memory

Refer to "General Notes Relating to Pepperl+Fuchs Product Information".

If you change the node number, you will need to cycle power (after you save your settings) for the node number to change. Once you cycle power, you will need to enter the new node number in your identifier. You can confirm everything is saved in non-volatile memory by cycling power.

**Receive:**

- 18FFAA20: Positional and speed data
- 18EA2000: Read response

**Model number**



**Connection type**

- C1** Cable, 1 m
- C2** Cable, 2 m
- C5** Cable, 5 m
- CA** Cable, 10 m
- BD** M12 device plug, 5-pin

**Connection alignment**

- A** axial
- R** radial

**Interface, electric**

- B20** J1939, U<sub>B</sub> = 9 ... 30 V

**Singleturn resolution**

- 13** 13 bit
- 16** 16 bit

**Multiturn resolution**

- 00** Singleturn rotary encoder
- 12** Multiturn rotary encoder, 12 bit
- 13** Multiturn rotary encoder, 13 bit
- 14** Multiturn rotary encoder, 14 bit
- 15** Multiturn rotary encoder, 15 bit

**Degree of protection**

- 5** IP65
- 7** IP67

**Flange**

- DA** Dual spring plate

**Shaft diameter**

- 06** 6 mm (d = 6F7)
- 10** 10 mm (d = 10F7)
- 12** 12 mm (d = 12F7)
- 14** 14 mm (d = 14F7)
- 15** 15 mm (d = 15F7)

**Shaft type**

- R** Recessed hollow shaft

**Version**

- IL** Industrial Line

**Size**

- 58** Housing diameter 58 mm

**Device type**

- ENA** Absolute rotary encoder

Release date: 2019-01-30 13:22 Date of issue: 2019-01-30 1185557\_eng.xml