



Model Number

ENA58IL-S***-J1939

Features

- Solid shaft
- Up to 31 bit overall resolution
- CAN bus with SAE J1939 protocol
- Free of wear magnetic sampling
- High resolution and accuracy

Description

This absolute rotary encoder provides a position value corresponding to the shaft position on its integrated J1939 interface. The rugged miniature encoders are based on magnetic sampling.

Technical data

General specifications

Detection type	magnetic sampling
Device type	Absolute encoders
Linearity error	$\leq \pm 0.1^\circ$
UL File Number	E223176 "For use in NFPA 79 Applications only" , if UL marking is marked on the product.

Functional safety related parameters

MTTF _d	480 a at 40 °C
Mission Time (T _M)	20 a
L ₁₀	55 E+8 revolutions at 40/110 N axial/radial shaft load
Diagnostic Coverage (DC)	0 %

Indicators/operating means

LED green	Operating mode
LED red	wrong baud rate

Electrical specifications

Operating voltage U _B	9 ... 30 V DC (with galvanic isolation)
Power consumption P ₀	≤ 1.2 W
Time delay before availability t _v	< 250 ms
Output code	binary code
Code course (counting direction)	adjustable

Interface

Interface type	J1939
Resolution	
Single turn	up to 16 Bit
Multiturn	up to 15 Bit
Overall resolution	up to 31 Bit
Transfer rate	min. 20 kBit/s , max. 1 MBit/s
Cycle time	≥ 1 ms
Standard conformity	ISO 11898

Connection

Connector	M12 connector, 5 pin
Cable	Ø6 mm, 4 x 2 x 0.14 mm ²

Standard conformity

Degree of protection	DIN EN 60529, IP65 or IP67
Climatic testing	DIN EN 60068-2-3, no moisture condensation
Emitted interference	EN 61000-6-4:2007
Noise immunity	EN 61000-6-2:2005
Shock resistance	DIN EN 60068-2-27, 200 g, 6 ms
Vibration resistance	DIN EN 60068-2-6, 20 g, 10 ... 1000 Hz

Ambient conditions

Operating temperature	cable, flexing: -5 ... 70 °C (23 ... 158 °F), cable, fixed: -30 ... 70 °C (-22 ... 158 °F) connector models: -40 ... 85 °C (-40 ... 185 °F)
Storage temperature	-40 ... 85 °C (-40 ... 185 °F)
Relative humidity	98 % , no moisture condensation

Mechanical specifications

Material	
Housing	nickel-plated steel , painted
Flange	Aluminum
Shaft	Stainless steel
Mass	approx. 300 g
Rotational speed	max. 12000 min ⁻¹
Moment of inertia	50 gcm ²
Starting torque	< 5 Ncm
Shaft load	
Axial	40 N
Radial	110 N

Approvals and certificates

UL approval	cULus Listed, General Purpose, Class 2 Power Source , if UL marking is marked on the product.
-------------	---

Dimensions

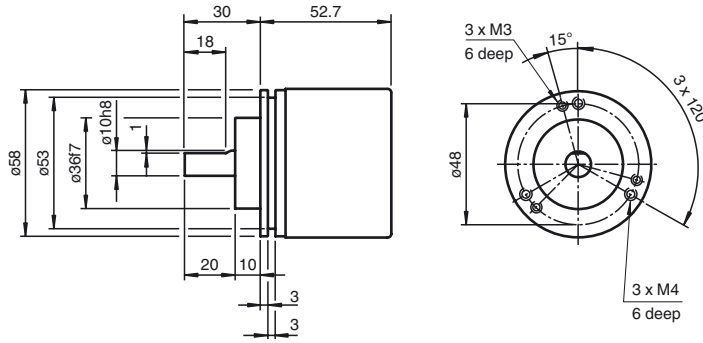

Clamping flange

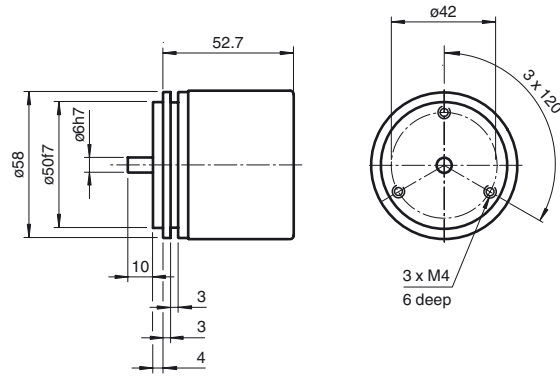

Servo flange

Connections

Dimensions in mm

Cable

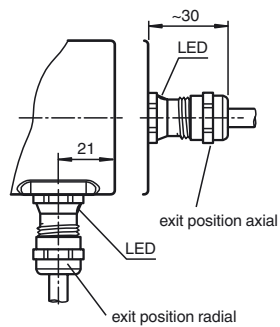

Connector M12

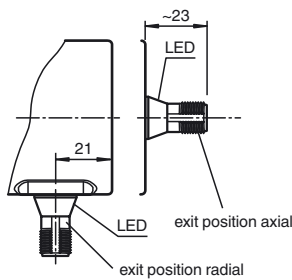

Release date: 2019-01-30 13:22 Date of issue: 2019-01-30 t185582_eng.xml

Electrical connection

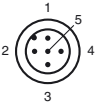
Signal	Wire end	5-pin, M12 x 1 connector
CAN GND	green	1
+V _S	red	2
GND	yellow	3
CAN-High	white	4
CAN-Low	brown	5
Shielding	Shielding	Housing
Pinout		

Example of the transmit commands

Command	Identifier	Data	Comments
Read request Direction	18EA2000	01 EF 00 00 00 00 00 00	
Read request Node	18EA2000	08 EF 00 00 00 00 00 00	
Write Direction	00EF2000	01 01 00 00 00 FF FF FF (CCW increase position)	When you change direction it will give you a different positional value. You will then need to set your preset value.
Write PRESET	00EF2000	04 A8 61 00 00 FF FF FF (value 25.000)	The preset value should be received at positional value 18FFAA20.
Write Save	00EF2000	FA 73 61 76 65 FF FF FF	The settings saved in non-volatile memory

If you change the node number, you will need to cycle power (after you save your settings) for the node number to change. Once you cycle power, you will need to enter the new node number in your identifier. You can confirm everything is saved in non-volatile memory by cycling power.

Receive:

18FFAA20: Positional and speed data

18EA2000: Read response

Model number

E N A 5 8 I L - S - - - - - B 2 0 - - - -

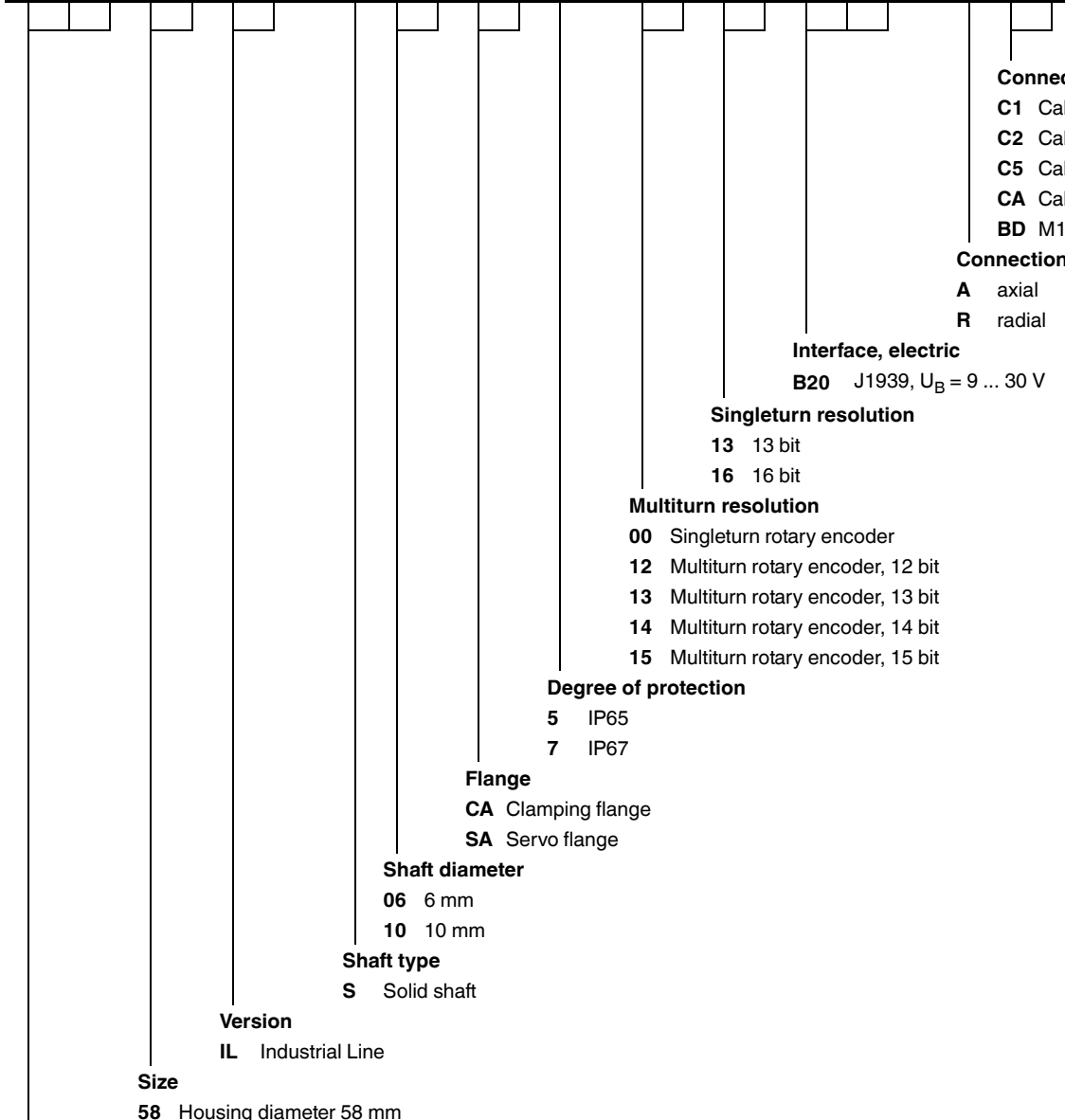

Connection type

- C1** Cable, 1 m
- C2** Cable, 2 m
- C5** Cable, 5 m
- CA** Cable, 10 m
- BD** M12 device plug, 5-pin

Connection alignment

- A** axial
- R** radial

Interface, electric

B20 J1939, U_B = 9 ... 30 V

Singleturn resolution

- 13** 13 bit
- 16** 16 bit

Multiturn resolution

- 00** Singleturn rotary encoder
- 12** Multiturn rotary encoder, 12 bit
- 13** Multiturn rotary encoder, 13 bit
- 14** Multiturn rotary encoder, 14 bit
- 15** Multiturn rotary encoder, 15 bit

Degree of protection

- 5** IP65
- 7** IP67

Flange

- CA** Clamping flange
- SA** Servo flange

Shaft diameter

- 06** 6 mm
- 10** 10 mm

Shaft type

- S** Solid shaft

Version

- IL** Industrial Line

Size

- 58** Housing diameter 58 mm

Device type

- ENA** Absolute rotary encoder