



Model Number

RVI58X-*****1

Features

- Industrial standard housing Ø58 mm
- ATEX approval
- Up to 5000 ppr
- Servo or clamping flange
- 10 V ... 30 V with short-circuit proof push-pull output

Description

Compatibility says it all for this incremental rotary encoder.

All six output channels are fitted for this incremental rotary encoder. It can thus be used universally in many different applications.

Focussing on the designs that are most often required has allowed us to offer rapid availability at an attractive price.

The pulse disk is designed in plastic up to 1500 pulses. Beyond that, glass is used.

This incremental rotary encoder is available either in clamping flange design with a shaft 10 mm in diameter x 20 mm or in servo flange design with a shaft 6 mm in diameter x 10 mm.

The electrical connection is made by a cable.

This incremental encoder is designed for operation in zone 2 and zone 22.

Technical data

General specifications

Detection type	photoelectric sampling
Pulse count	max. 5000

Functional safety related parameters

MTTF _d	140 a
Mission Time (T _M)	20 a
L ₁₀	70 E+9 at 6000 rpm
Diagnostic Coverage (DC)	0 %

Electrical specifications

Operating voltage U _B	10 ... 30 V DC
No-load supply current I ₀	max. 60 mA

Output

Output type	push-pull, incremental
Voltage drop U _d	< 3 V
Load current	max. per channel 40 mA, short-circuit protected (not with U _b), reverse polarity protected
Output frequency	max. 200 kHz
Rise time	400 ns

Connection

Cable	Ø7.8 mm, 6 x 2 x 0.14 mm ² , 1 m
-------	---

Standard conformity

Degree of protection	DIN EN 60529, IP64
Climatic testing	DIN EN 60068-2-3, no moisture condensation
Emitted interference	EN 61000-6-4:2007/A1:2011
Noise immunity	EN 61000-6-2:2005
Shock resistance	DIN EN 60068-2-27, 100 g, 3 ms
Vibration resistance	DIN EN 60068-2-6, 10 g, 10 ... 2000 Hz

Ambient conditions

Operating temperature	
Glass disk	-30 ... 70 °C (-22 ... 158 °F), fixed cable
Plastic disk	-30 ... 60 °C (-22 ... 140 °F), fixed cable
Storage temperature	
Glass disk	-30 ... 70 °C (-22 ... 158 °F)
Plastic disk	-30 ... 70 °C (-22 ... 158 °F)

Mechanical specifications

Material	
Housing	powder coated aluminum
Flange	Aluminum
Shaft	Stainless steel
Mass	approx. 350 g
Rotational speed	max. 6000 min ⁻¹
Moment of inertia	≤ 25 gcm ²
Starting torque	≤ 1.5 Ncm
Shaft load	
Axial	40 N
Radial	60 N

Data for application in connection with hazardous areas

ATEX marking	II 3G Ex nA IIB T4 Gc X II 3D Ex tc IIIC T105°C Dc X
Certificate	PF 18 CERT 4775 X
Directive conformity	EN 60079-0:2012+A11:2013, EN 60079-15:2010, EN 60079-14:2014

Approvals and certificates

UL approval	cULus Listed, General Purpose, Class 2 Power Source
-------------	---

Dimensions

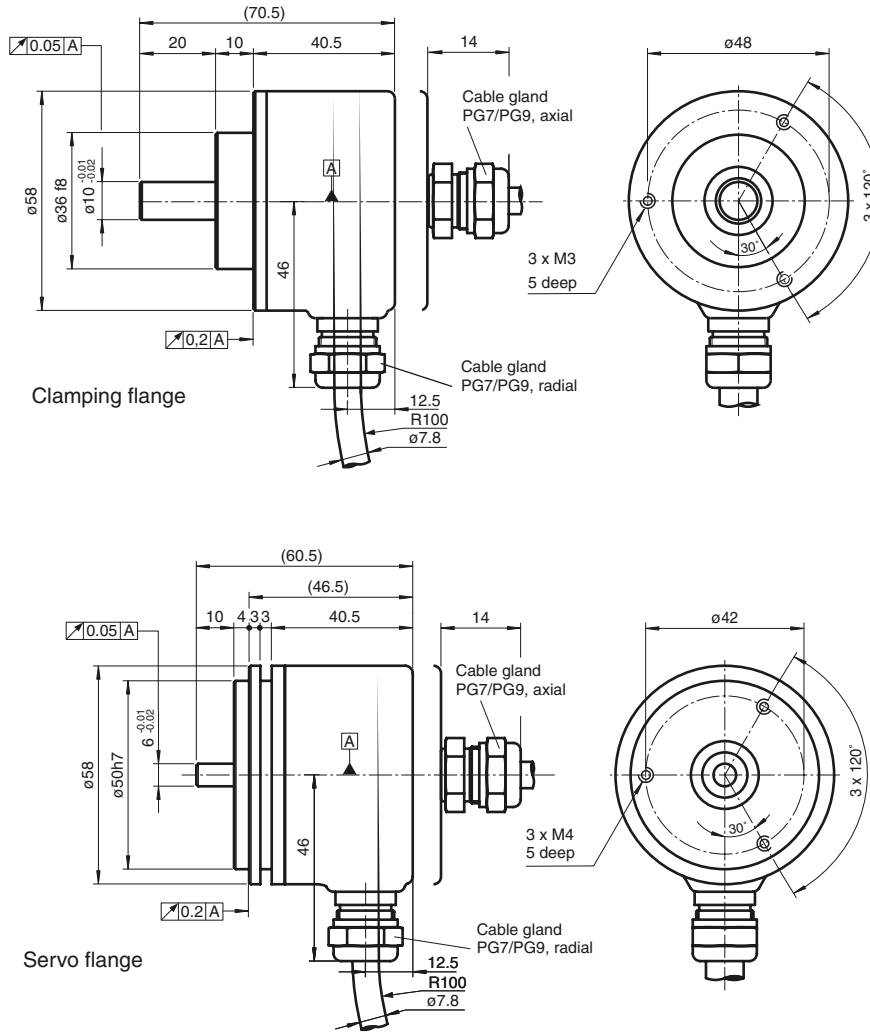

Release date: 2018-07-31 13:41 Date of issue: 2018-11-26 t31551_eng.xml

Electrical connection

Signal	Cable Ø7.8 mm, 12-core
GND	White
U_b	Brown
A	Green
B	Grey
\bar{A}	Yellow
\bar{B}	Pink
0	Blue
$\bar{0}$	Red
NC	Grey/Pink
U_b Sens *)	Violet
GND Sens *)	Black
Screen	-

*) only for devices with 5 V supply and RS 422 interface

Signal outputs

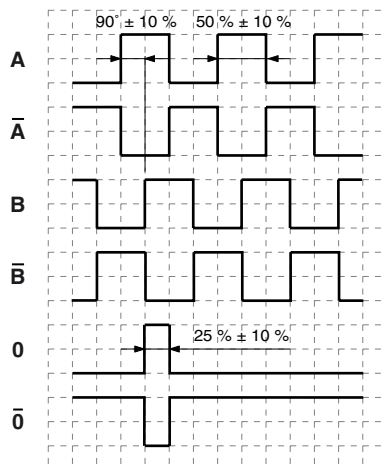

↻ cw - with view onto the shaft

Order code

R	V	I	5	8	X	-				K	1		6		N	-				
---	---	---	---	---	---	---	--	--	--	---	---	--	---	--	---	---	--	--	--	--

Pulse count 100, 360, 500, 512, 1000, 1024, 1250, 2048, 2500, 3600, 4096, 5000

Option

N Normal

Output switching

1 10 V ... 30 V, push-pull

6 5 V, RS 422

X 10 V ... 30 V, RS 422

Signal output

6 A + B + 0 and \bar{A} + \bar{B} + $\bar{0}$

Exit position

A Axial

R Radial

Connection type

K1 Cable Ø7.8 mm, 6 x 2 x 0.14 mm², 1 m

Shaft dimension/flange version

011 Shaft Ø10 mm x 20 mm with clamping flange

032 Shaft Ø6 mm x 10 mm with servo flange

Housing material

X design for hazzardous areas

Shaft version

V Solid shaft