

**Features**

- Interface between the I/O modules and the PCS/PLC
- Com unit for 80 analog or 184 digital channels
- Communication via PROFIBUS DP
- Mounting in Zone 2, Class I/Div.2 or in the safe area
- HART communication via PROFIBUS DP V1 or service bus
- Configuration via FDT 1.2 DTM
- Non-volatile memory for configuration and parameter settings
- Self configuration in redundant systems
- Permanently self-monitoring
- Outputs drive to safe state in case of failures
- Module can be exchanged under voltage

**Function**

The PROFIBUS com unit forms the interface between the I/O modules on the backplane and the process control system. It supports all single width and dual width I/O modules. Thereby signals from NAMUR sensors, mechanical contacts, high-power solenoid drivers, power relays, sounders, and alarm LEDs are transported to the higher-level bus system. The com unit can be easily configured via DTM and supports redundancy as well as HART.

**Assembly**

Front view

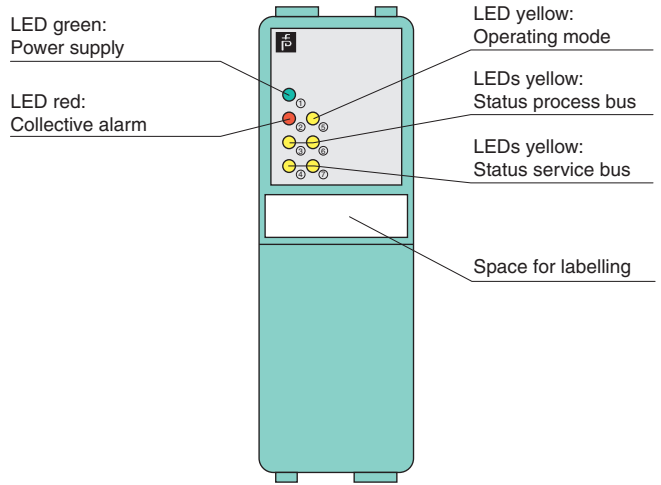

**Connection**

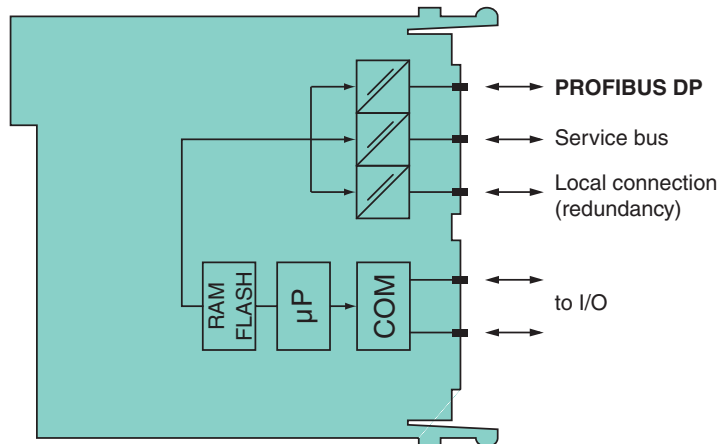

Zone 2  
Div. 2

Release date 2017-10-05 17:32 Date of issue 2017-10-05 t35025\_eng.xml

Refer to "General Notes Relating to Pepperl+Fuchs Product Information".

<b>Supply</b>	
Connection	backplane bus
Rated voltage $U_r$	5 V DC , only in connection with the power supplies LB9***
Power consumption	2 W
<b>Fieldbus interface</b>	
Fieldbus type	PROFIBUS DP/DP-V1
<b>PROFIBUS DP</b>	
Connection	9-pin Sub-D socket via backplane
Baud rate	up to 1.5 MBit/s
Protocol	PROFIBUS DP/DP V1 read/write services
Number of stations per bus line	≤ 125 (PROFIBUS), ≤ 119 (service bus)
Cyclic process data	240 bytes in total, either input or output data
Number of stations per bus segment	≤ 31 (RS-485 standard)
Number of repeaters between Master and Slave	max. 3
Supported I/O modules	all LB remote I/O modules
Bus length	≤ 1000 m (FOL, 1.5 MBaud), ≤ 1000 m (copper cable, 187.5 kBd), ≤ 200 m (copper cable, 1.5 MBd)
Addressing	via configuration software
PROFIBUS address	0 ... 126 (factory standard setting: 126)
GSE file	CGV61710.gsd/gse
HART communication	via PROFIBUS or service bus
<b>Internal bus</b>	
Connection	backplane bus
Redundancy	via backplane
<b>Indicators/settings</b>	
LED indicator	LED 1 (power supply): On = operating, fast flash = cold start, slow flash = HCIR loading active LED 2 (collective alarm): On = internal fault, flashing = no PROFIBUS connection LED 3 (status process bus): flashing = PROFIBUS receive channel active LED 4 (status service bus): flashing = service bus receive channel active LED 5 (operating mode): flashing 1 (1:1 ratio) = active, normal operation; flashing 2 (7:1 ratio) = active, simulation LED 6 (status process bus): flashing = PROFIBUS response channel active LED 7 (status servicebus): flashing = service bus response channel active
<b>Directive conformity</b>	
Electromagnetic compatibility	
Directive 2014/30/EU	EN 61326-1
<b>Conformity</b>	
Electromagnetic compatibility	NE 21
Degree of protection	IEC 60529
Fieldbus standard	IEC 61158-2
Environmental test	EN 60068-2-14
Shock resistance	EN 60068-2-27
Vibration resistance	EN 60068-2-6
Damaging gas	EN 60068-2-42
Relative humidity	EN 60068-2-56
<b>Ambient conditions</b>	
Ambient temperature	-20 ... 60 °C (-4 ... 140 °F)
Storage temperature	-25 ... 85 °C (-13 ... 185 °F)
Relative humidity	95 % non-condensing
Shock resistance	shock type I, shock duration 11 ms, shock amplitude 15 g, number of shocks 18
Vibration resistance	frequency range 10 ... 150 Hz; transition frequency: 57.56 Hz, amplitude/acceleration ± 0.075 mm/1 g; 10 cycles frequency range 5 ... 100 Hz; transition frequency: 13.2 Hz amplitude/acceleration ± 1 mm/0.7 g; 90 minutes at each resonance
Damaging gas	designed for operation in environmental conditions acc. to ISA-S71.04-1985, severity level G3
<b>Mechanical specifications</b>	
Degree of protection	IP20 (module) , mounted on backplane
Connection	via backplane
Mass	approx. 120 g
Dimensions	32.5 x 100 x 102 mm (1.28 x 3.9 x 4 inch)
<b>Data for application in connection with hazardous areas</b>	
Certificate	PF 08 CERT 1234 X
Marking	 II 3 G Ex nA IIC T4 Gc

Release date 2017-10-05 17:32 Date of issue 2017-10-05 t35025\_eng.xml

Refer to "General Notes Relating to Pepperl+Fuchs Product Information".

<b>Directive conformity</b>	
Directive 2014/34/EU	EN 60079-0:2009 EN 60079-11:2007 EN 60079-15:2010
<b>International approvals</b>	
ATEX approval	PF 08 CERT 1234 X
UL approval	E106378
Control drawing	116-0321
Approved for	cUL (Canada): CL I Zn. 2 IIC; IS circuits for CL I Zn. 0 IIC ULus (USA): CL I Div. 2 Grp. A, B, C, D; IS circuits for CL I, II, III Div. 1 Grp. A, B, C, D, E, F, G
IECEX approval	BVS 09.0037X
Approved for	Ex nA IIC T4 Gc
EAC approval	Russia: RU C-IT.MIII06.B.00129
<b>Marine approval</b>	
Lloyd Register	15/20021
DNV GL Marine	TAA0000034
American Bureau of Shipping	T1450280/UN
Bureau Veritas Marine	22449/B0 BV
<b>General information</b>	
System information	The module has to be mounted in appropriate backplanes (LB9***) in Zone 2 or outside hazardous areas. Here, observe the corresponding declaration of conformity. For use in hazardous areas (e. g. Zone 2, Zone 22 or Div. 2) the module must be installed in an appropriate enclosure.
Supplementary information	EC-Type Examination Certificate, Statement of Conformity, Declaration of Conformity, Attestation of Conformity and instructions have to be observed where applicable. For information see <a href="http://www.pepperl-fuchs.com">www.pepperl-fuchs.com</a> .

**Versions**

Bus couplers are available with different firmware versions. The type code extension \* designates the firmware version.

Release date 2017-10-05 17:32 Date of issue 2017-10-05 t35025\_eng.xml