

## Ultrasonic level sensor

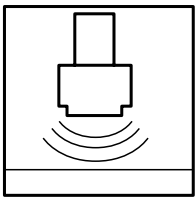

### LUC-M\*\*



### Features

- Quick and simple commissioning via menu-guided onsite operation with four-line display
- Envelope curves on the on-site display for simple diagnosis
- Linearization function (up to 32 points) for conversion of the measured value into any unit of length, volume or flow rate
- Non-contact measurement method minimises service requirements
- Optional remote display and operation (up to 20 m from transmitter)
- Integrated temperature sensor for automatic correction of the temperature dependent sound velocity

## Dimensions

LUC-M20 with F12 housing and process connection 2"

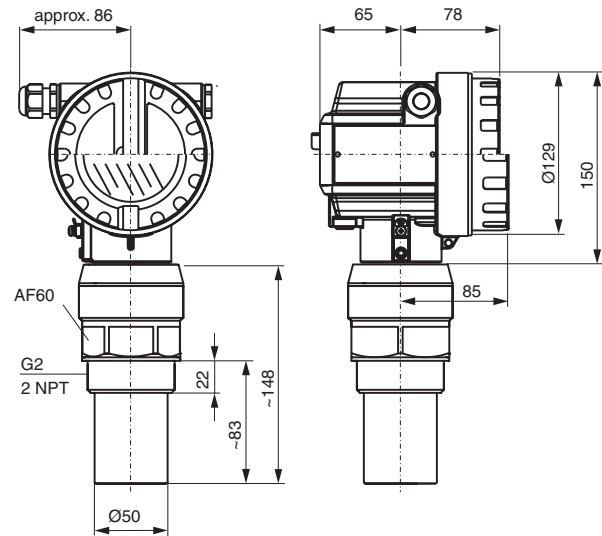

Additional dimensions see section dimensions.

### Function

The LUC-M\*\* is a compact measuring device for continuous, non-contact level measurement. Depending on the sensor, the measuring range is up to 15 m in fluids and up to 7 m in bulk solids. By using the linearisation function, the LUC-M\*\* can also be used for flow measurements in open channels and measuring weirs.

The system integration is ensured via

- HART (standard), 4 mA ... 20mA and
- PROFIBUS PA.

The maximum measuring range with

- LUC-M10: 5 m (16.4 ft) in fluids and 2 m (6.6 ft) in bulk materials,
- LUC-M20: 8 m (26.2 ft) in fluids and 3,5 m (11.5 ft) in bulk materials,
- LUC-M30: 15 m (49.2 ft) in fluids and 7 m (23 ft) in bulk materials,
- LUC-M40: 10 m (32.8 ft) in fluids and 5 m (16.4 ft) in bulk materials.

### Electrical connection

Connection IH, 4 mA ... 20 mA with HART, 2-wire (example)

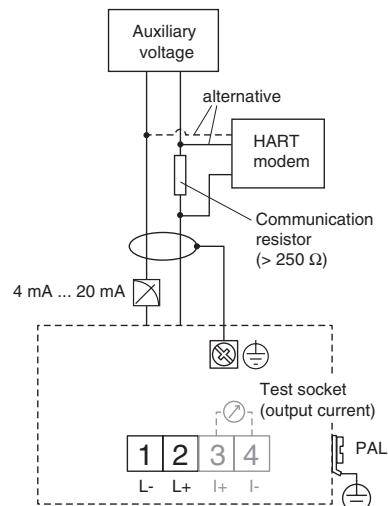

Other connection types see section electrical connection.

<b>Function and system design</b>	
Measuring principle	The sensor of the LUC-M** transmits ultrasonic pulses in the direction of the product surface. There, they are reflected back and received by the sensor. The LUC-M** measures the time between pulse transmission and reception. The instrument uses the time (and the velocity of sound) to calculate the distance between the sensor membrane and the product surface. As the device knows the empty distance from a user entry, it can calculate the level.
Equipment architecture	4 ... 20 mA output with HART protocol system integration via PROFIBUS PA
<b>Input characteristics</b>	
Measured variable	distance between the sensor membrane and the product surface using the linearization function, the device calculate - level in any units - volume in any units - flow across measuring weirs or open channels in any units
Measuring range	LUC-M10: max. 5 m (16.4 ft) in fluids and 2 m (6.6 ft) in bulk materials LUC-M20: max. 8 m (26.2 ft) in fluids and 3,5 m (11.5 ft) in bulk materials LUC-M30: max. 15 m (49.2 ft) in fluids and 7 m (23 ft) in bulk materials LUC-M40: max. 10 m (32.8 ft) in fluids and 5 m (16.4 ft) in bulk materials
Blocking distance	LUC-M10: 0.25 m (0.8 ft) LUC-M20: 0.35 m (1 ft) LUC-M30: 0.6 m (2 ft) LUC-M40: 0.4 m (1.3 ft)
Operating frequency	LUC-M10: approx. 70 kHz LUC-M20: approx. 50 kHz LUC-M30: approx. 35 kHz LUC-M40: approx. 42 kHz
<b>Output characteristics</b>	
Output signal	according to the instrument version: - 4 ... 20 mA with HART protocol - PROFIBUS PA
Signal on alarm	error information can be accessed via the following interfaces: - on-site display (error symbol, error code and plain text description) - current output (configurable) - digital interface
Output damping	0 ... 255 s , freely selectable
Load	minimum load for HART communication: 250 Ω
Linearisation	The linearization function of the LUC-M** allows conversion of the measured value into any unit of length or volume. In open channels or measuring weirs, also a flow linearization is possible (calculation of the flow from the measured level).
<b>Auxiliary energy</b>	
Electrical connection	terminal compartment: In the F12 housing, the terminals are located underneath the housing cover, in the T12 housing, they are under the cover of the separate terminal compartment. cable gland: M20 x 1.5 (recommended cable diameter 6 ... 10 mm (0.24 ... 0.4 in)) cable entry G1/2 or 1/2 NPT PROFIBUS PA: M12 plug connector
Supply voltage	2-wire HART (standard): - current consumption 4 ... 20 mA - min. terminal voltage 14 V (at 4 mA), 8 V (at 20 mA) - max. terminal voltage 36 V 4-wire HART: - DC version: voltage 10.5 ... 32 V, max. load 600 Ω - AC version: 90 ... 253 V, max. load 600 Ω PROFIBUS PA: 9 ... 32 V DC for additional information see technical information
Power consumption	2-wire: 51 ... 800 mW 4-wire AC: max. 4 VA 4-wire DC, LUC-M10/LUC-M20: 330 ... 830 mW 4-wire DC, LUC-M30/LUC-M40: 0.6 ... 1 W
Current consumption	2-wire devices: - HART: 3.6 ... 22 mA - PROFIBUS PA: max. 13 mA
Ripple	HART: 47 ... 125 Hz , $U_{pp} = 200$ mV (measured at 500 Ω)
Noise	HART: 0.5 ... 10 kHz , $U_{rms} = 2.2$ mV (measured at 500 Ω)
Electrical isolation	With 4-wire devices, the evaluation electronics and mains voltage are galvanically isolated from each other.
Terminal assignment	see section electrical connection
<b>Performance characteristics</b>	
Response time	depends on the parameter settings: - min. 0.5 s for 4-wire devices - min. 2 s for 2-wire devices

Release date 2009-12-21 11:29 Date of issue 2009-12-21 T47783\_ENG.xml

Reference operating conditions	<p>temperature = 20 °C (293 K)                  pressure = 1013 mbar<sub>abs</sub>                  humidity = 50 %                  ideal reflective surface (e. g. calm, smooth fluid surface)                  no interference reflections within signal beam                  set application parameters:                  - tank shape = flat ceiling                  - medium property = liquid                  - process conditions = calm surface</p>
Measured value resolution	<p>LUC-M10, LUC-M20: 1 mm (0.04 in)                  LUC-M30, LUC-M40: 2 mm (0.08 mm)</p>
Measuring frequency	<p>2-wire devices: max. 0.5 Hz                  4-wire devices: max. 2 Hz                  dependent on the type of device and the parameter settings</p>
Maximum measured error	<p>typical specifications for reference operating conditions (include linearity, repeatability, and hysteresis):                  LUC-M10, LUC-M20: ± 2 mm (0.08 in) or 0.2% of set measuring range (empty calibration)<sup>1)</sup>                  LUC-M30, LUC-M40: ± 4 mm (0.16 in) or 0.2% of set measuring range (empty calibration)<sup>1)</sup>  <sup>1)</sup> whichever is greater</p>
<b>Operating conditions</b>	
Mounting conditions	see technical information
Ambient conditions	
Ambient temperature	-40 ... 80 °C (233 ... 353 K) , for additional information see technical information
Storage temperature	-40 ... 80 °C (233 ... 353 K)
Resistance to alternating temperature cycles	Nb test: +80 °C/- 40 °C (353 K/233 K), 1 K/min, 100 cycles
Vibration resistance	20 ... 2000 Hz, 1 (m/s <sup>2</sup> )/Hz; 3 x 100 min
Process conditions	
Process temperature	-40 ... 80 °C (233 ... 353 K) (233 ... 353 K), a temperature sensor is integrated in the sensor for correction of the temperature-dependent time-of-flight
Process pressure (static pressure)	LUC-M10, LUC-M20: 0.7 ... 3 bar <sub>abs</sub> LUC-M30, LUC-M40: 0.7 ... 2.5 bar <sub>abs</sub>
<b>Mechanical specifications</b>	
Protection degree	<p>with closed housing, tested according to                  - IP68, Nema 6p (24 h at 1.83 m under water surface)                  - IP66, Nema 4x                  with open housing: IP20, Nema 1 (also ingress protection of the display)</p>
<b>Mechanical construction</b>	
Construction type	<p>housing design:                  - F12 housing with sealed terminal compartment for standard or EEx ia applications                  - T12 housing with separate terminal compartment and explosion proof encapsulation cover:                  - version without on-site display                  - version with on-site display (transparent cover), this version cannot be supplied together with the ATEX II 1/2D certificate</p>
Dimensions	see section dimensions
Mass	<p>LUC-M10: approx. 2.5 kg                  LUC-M20: approx. 2.6 kg                  LUC-M30: approx. 3.5 kg                  LUC-M40: approx. 3 kg</p>
Material	<p>material in contact with process:                  - LUC-M10, LUC-M20: sensor PVDF, seal EPDM                  - LUC-M30: sensor UP and stainless steel 1.4571/316Ti, seal EPDM, flange PP or stainless steel 1.4571/316Ti                  - LUC-M40: sensor PVDF, seal Viton or EPDM, flange PP, PVDF or stainless steel 1.4535/316L                  housing:                  - aluminium, seawater resistant, chromed, powder-coated                  cover:                  - aluminium, for version without on-site display                  - inspection glass for version with on-site display</p>
Process connection	<p>- cylindrical thread G1½B, G2B to DIN ISO 228/1                  - conical thread 1½ NPT, 2 NPT to ANSI B 1.20.1                  - flanges to EN 1092-1 from DN80, to ANSI B 16.5 from 3", to JIS B 2238 (RF) from DN80                  - mounting bracket LUC-Z17</p>
Electrical connection	<p>cable gland M20 x 1.5                  cable gland ½ NPT                  cable gland G½                  PROFIBUS PA plug M12 x 1</p>
<b>Indication and operation</b>	
Display elements	LCD module LUC-Z15 at the device

Release date 2009-12-21 11:29 Date of issue 2009-12-21 T47789\_ENG.xml

Operating elements	<p>on-site operation:</p> <ul style="list-style-type: none"> <li>- via 3 keys of the LCD module LUC-Z15</li> <li>- via handheld terminal</li> </ul> <p>remote control:</p> <ul style="list-style-type: none"> <li>- operation with operating program (for communication variants HART or PROFIBUS-PA)</li> </ul>
<b>Certificates and approvals</b>	
Ex approval	KEMA 05 ATEX 1111, KEMA 05 ATEX 1112 , for additional certificates see <a href="http://www.pepperl-fuchs.com">www.pepperl-fuchs.com</a>
Type of protection	<p>⊕ II 1/2G or II 2G EEx ia IIC T6 (KEMA 05 ATEX 1111)</p> <p>⊕ II 1/2G or II 2G EEx d [ia] IIC T6 (KEMA 05 ATEX 1111)</p> <p>⊕ II 1/2G or II 2G EEx em [ia] IIC T6 (KEMA 05 ATEX 1111)</p> <p>⊕ II 1/2D or II 2D or II 1/3D or II 3D T115°C or T100°C or T95°C (KEMA 05 ATEX 1111)</p> <p>⊕ II 1/2D or II 2D or II 1/3D or II 3D T115°C or T83°C or T84°C or T86°C (KEMA 05 ATEX 1112)</p> <p>⊕ II 3G EEx nA II T6</p>
<b>General information</b>	
Directive conformity	
Directive 73/23/EEC (Low Voltage Directive)	EN 61010-1
Directive 89/336/EEC (EMC)	<p>emitted interference to EN 61326, class B equipment</p> <p>interference immunity to EN 61326, annex A (industrial sector)</p> <p>A standard installation cable is sufficient if only the analogue signal is used. Use a screened cable when working with a superimposed communication signal (HART).</p>
Directive 94/9/EC (ATEX)	EN 50014, EN 50018, EN 50019, EN 50020, EN 50028, EN 50281-1-1, EN 50284
Conformity	
Electromagnetic compatibility	NE 21
Protection degree	EN 60529
Climate class	EN 60068-2-38 (test Z/AD) DIN/IEC 68 T2-30Db
Vibration resistance	EN 60068-2-64
Resistance to alternating temperature cycles	EN 60068-2-14
Supplementary documentation	<p>technical information TI365O</p> <p>short instructions KA183O (can be found under the device housing cover)</p> <p>operating instructions KA191O (connection LUC-M**)</p> <p>operating instructions BA237O (4 ... 20 mA, HART devices)</p> <p>operating instructions BA238O (PROFIBUS PA devices)</p> <p>operating instructions BA240O (description of device functions)</p> <p>safety information SI174O (KEMA 05 ATEX 1111), HART devices</p> <p>safety information SI175O (KEMA 05 ATEX 1111), PROFIBUS PA devices</p> <p>safety information SI176O (KEMA 05 ATEX 1111)</p> <p>safety information SI177O (KEMA 05 ATEX 1112), HART devices</p> <p>safety information SI178O (KEMA 05 ATEX 1112), PROFIBUS PA devices</p> <p>safety information SI179O (⊕ II 3G EEx nA II T6)</p> <p>safety information SI180O (KEMA 05 ATEX 1111)</p> <p>safety information SI224O (KEMA 05 ATEX 1111), HART devices</p> <p>safety information SI225O (KEMA 05 ATEX 1111), PROFIBUS PA devices</p> <p>safety information SI259O (KEMA 05 ATEX 1111), HART devices</p> <p>FM control drawing ZD096O (HART devices, F12 housing)</p> <p>FM control drawing ZD097O (PROFIBUS PA devices)</p> <p>FM control drawing ZD098O (T12 housing)</p> <p>FM control drawing ZD139O (HART devices, T12-OVP housing)</p> <p>FM control drawing ZD140O (PROFIBUS PA devices, T12-OVP housing)</p> <p>CSA control drawing ZD088O (HART devices, F12 housing)</p> <p>CSA control drawing ZD099O (PROFIBUS PA devices)</p> <p>CSA control drawing ZD100O (T12 housing)</p> <p>CSA control drawing ZD101O (HART devices, T12 housing)</p> <p>CSA control drawing ZD102O (PROFIBUS PA devices)</p>
Supplementary information	EC-Type Examination Certificate, Statement of Conformity, Declaration of Conformity, Attestation of Conformity and instructions have to be observed where applicable. For information see <a href="http://www.pepperl-fuchs.com">www.pepperl-fuchs.com</a> .

Release date 2009-12-21 11:29 Date of issue 2009-12-21 T47789\_ENG.xml

Electrical connection

Connection IH  
4 mA ... 20 mA with HART, 2-wire

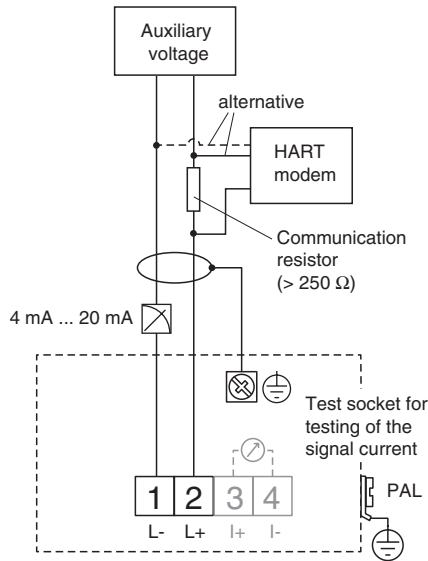

Connection AH, DH  
4 mA ... 20 mA with HART, active, 4-wire

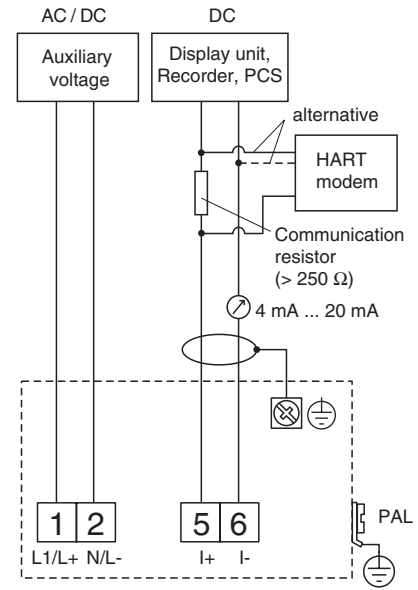

- Connect the connecting line to the screw terminals (line cross-sections of 0.5 mm... 2.5mm) in the terminal compartment.
- Use 2-wire twisted pair cable with screen for the connection.
- Protective circuitry against reverse polarity, RFI and over-voltage peaks is built into the device.

Connection PA  
PROFIBUS PA

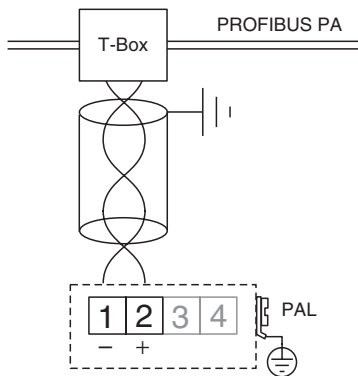

The digital communication signal is transmitted to the bus via a 2-wire connection. The bus also provides the auxiliary energy. Please use 2-wire twisted pair cable with screen.

Dimensions

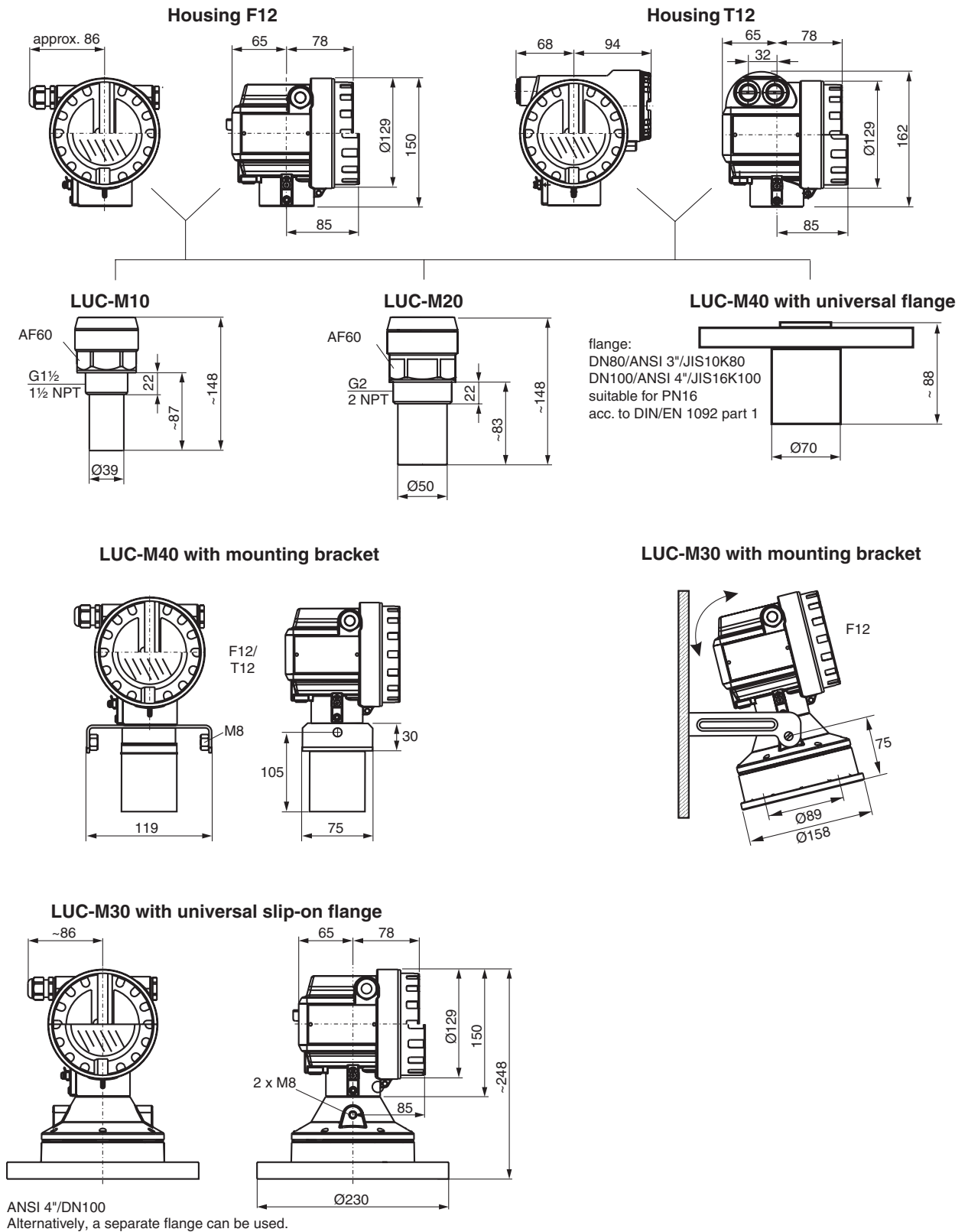

Release date 2009-12-21 11:29 Date of issue 2009-12-21 T47783\_ENG.xml

Blocking distance

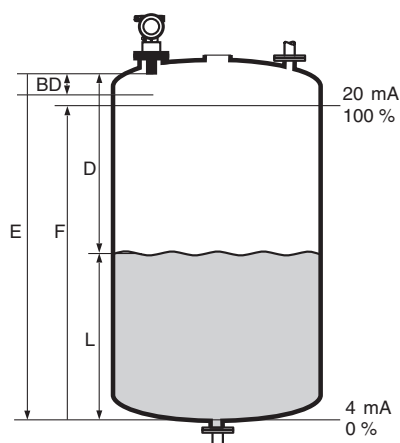

Sensor	BD	Max. range fluids	Max. range bulk materials
LUC-M10	0.25 m (9.8 in)	5 m (16.4 ft)	2 m (6.6 ft)
LUC-M20	0.35 m (13.8 in)	8 m (26.2 ft)	3.5 m (11.5 ft)
LUC-M30	0.6 m (23.6 in)	15 m (49.2 ft)	7 m (23 ft)
LUC-M40	0.4 m (15.7 in)	10 m (32.8 ft)	5 m (16.4 ft)

E: empty distance  
 F: span (full distance)  
 D: distance from sensor membrane - product surface  
 L: level  
 BD: blocking distance

Emitting angle

To estimate the detection range, use the 3 dB emitting angle  $\alpha$ . Make sure that equipment (1) such as limit switches, temperature sensors, etc. are not located within the emitting angle  $\alpha$ . In particular, symmetrical equipment (2) such as heating coils, baffles etc. can influence measurement.

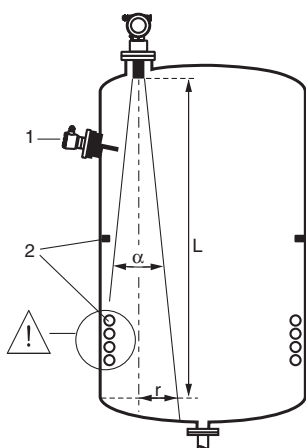

Sensor	$\alpha$	L	r
LUC-M10	11°	5 m (16.4 ft)	0.48 m (18.9 in)
LUC-M20	11°	8 m (26.2 ft)	0.77 m (30.3 in)
LUC-M30	6°	15 m (49.2 ft)	0.79 m (31.1 in)
LUC-M40	11°	10 m (32.8 ft)	0.96 m (37.8 in)

Accessories

Mounting accessories

- LUC-Z17, mounting bracket for LUC-M30, LUC-M40
- LUC-Z18, mounting bracket for LUC-M10
- LUC-Z19, mounting bracket for LUC-M20
- LUC-Z2\*, cantilever for LUC-M10, LUC-M20
- LUC-Z3\*, mounting frame
- LUC-Z5\*, wall bracket

Flanges

- LUC-Z-\*\*\*, universal slip-on flange for LUC-M30
- LUC-Z-A\*\*N\*\*, adapter flange with conical thread for LUC-M10, LUC-M20
- LUC-Z-F\*\*G\*\*, adapter flange with metrical thread for LUC-M10, LUC-M20

Further accessories

- LUC-Z15, display and operating module for on-site operation
- LUC-Z16, weather protection cover
- LUC-Z40-\*\*\*1\*, remote display





for additional information see technical information

Release date 2009-12-21 11:29 Date of issue 2009-12-21 T47783\_ENG.xml

Type code/model number

Product structure LUC-M10

L	U	C	-	M	1	0	-								
---	---	---	---	---	---	---	---	--	--	--	--	--	--	--	--

**Certificate**  
**NA** version for non-explosion hazardous areas  
**EX**  II 1/2G EEx ia IIC T6  
**ES**  II 1/2D, aluminium cover  
**E2**  II 1/3D  
**SX**  II 1/2G EEx d (ia) IIC T6  
**S2**  II 3G EEx nA II T6  
**F1** FM IS, Cl. I/II/III, Div.1 Group A-G, N.I .Cl. I, Div.2  
**F2** FM XP, Cl. I/II/III, Div. 1, Group A-G  
**CG** CSA, General Purpose  
**C1** CSA IS, Cl. I/II/III, Div. 1, Group A-D, G + coal dust, N.I.  
**C2** CSA XP, Cl. I/II/III, Div. 1, Group A-D, G + coal dust, N.I.

**Display**  
**A** \* prepared for remote display, order display as accessory LUC-Z40  
**B** without display  
**D** with display LUC-Z15 inclusive on-site operation, envelope curve display

**Electrical output**  
**AH** 4-wire, 90 V AC ... 250 V AC, 4 mA ... 20 mA, HART  
**DH** 4-wire, 10.5 V DC ... 32 V DC, 4 mA ... 20 mA, HART  
**IH** 2-wire, 4 mA ... 20 mA, HART  
**PA** 2-wire, PROFIBUS PA

**Cable entry**  
**2** cable gland M20 x 1.5  
**3** thread G½  
**4** thread ½ NPT  
**5** connector M12, PROFIBUS PA





**Housing**  
**A1** aluminium housing F12, IP68, thread M20 x 1.5  
**A2** aluminium housing T12, IP68, coated, with separate terminal compartment  
**A4** aluminium housing T12, IP68, coated, with separate terminal compartment, overvoltage protection

**Process connection**  
**G5** G1½B, ISO 228/1, PVDF  
**N5** 1½ NPT, ANSI B 1.20.1, PVDF

\* in preparation

Product structure LUC-M20

L	U	C	-	M	2	0	-								
---	---	---	---	---	---	---	---	--	--	--	--	--	--	--	--

**Certificate**  
**NA** version for non-explosion hazardous areas  
**EX**  II 1/2G EEx ia IIC T6  
**ES**  II 1/2D, aluminium cover  
**E2**  II 1/3D  
**SX**  II 1/2G EEx d (ia) IIC T6  
**S2**  II 3G EEx nA II T6  
**F1** FM IS, Cl. I/II/III, Div.1 Group A-G, N.I .Cl. I, Div.2  
**F2** FM XP, Cl. I/II/III, Div. 1, Group A-G  
**CG** CSA, General Purpose  
**C1** CSA IS, Cl. I/II/III, Div. 1, Group A-D, G + coal dust, N.I.  
**C2** CSA XP, Cl. I/II/III, Div. 1, Group A-D, G + coal dust, N.I.

**Display**  
**A** \* prepared for remote display, order display as accessory LUC-Z40  
**B** without display  
**D** with display LUC-Z15 inclusive on-site operation, envelope curve display

**Electrical output**  
**AH** 4-wire, 90 V AC ... 250 V AC, 4 mA ... 20 mA, HART  
**DH** 4-wire, 10.5 V DC ... 32 V DC, 4 mA ... 20 mA, HART  
**IH** 2-wire, 4 mA ... 20 mA, HART  
**PA** 2-wire, PROFIBUS PA

**Cable entry**  
**2** cable gland M20 x 1,5  
**3** thread G½  
**4** thread ½ NPT  
**5** connector M12, PROFIBUS PA

**Housing**  
**A1** aluminium housing F12, IP68, thread M20 x 1.5  
**A2** aluminium housing T12, IP68, coated, with separate terminal compartment  
**A4** aluminium housing T12, IP68, coated, with separate terminal compartment, overvoltage protection

**Process connection**  
**G6** G2B, ISO 228/1, PVDF  
**N6** 2 NPT, ANSI B 1.20.1, PVDF

\* in preparation

Release date 2009-12-21 11:29 Date of issue 2009-12-21 T47783\_ENG.xml



Type code/model number

Product structure LUC-M30



- Certificate**
- NA version for non-explosion hazardous areas
- ES II 1/2D, aluminium cover
- E2 II 1/3D
- FM FM DIP, Cl. II, Div.1 Group E-G, N.I .Cl. I, Div.2
- CG CSA, General Purpose
- CS CSA DIP, Cl. II, Div. 1, Group E-G, N.I .Cl. I, Div.2
- Display**
- A \* prepared for remote display, order display as accessory LUC-Z40
- B without display
- D with display LUC-Z15 inclusive on-site operation, envelope curve display
- Electrical output**
- AH 4-wire, 90 V AC ... 250 V AC, 4 mA ... 20 mA, HART
- DH 4-wire, 10.5 V DC ... 32 V DC, 4 mA ... 20 mA, HART
- PA 2-wire, PROFIBUS PA
- Cable entry**
- 2 cable gland M20 x 1,5
- 3 thread G½
- 4 thread ½ NPT
- 5 connector M12, PROFIBUS PA
- Housing**
- A1 aluminium housing F12, IP68, thread M20 x 1.5
- Process connection**
- FA universal flange DN100/ANSI 4"/JIS16K100, PP
- FS universal flange DN100/ANSI 4"/JIS16K100, 1.4571/316Ti
- FK without slip-on flange, without mounting bracket, customer mounting equipment
- FM with mounting bracket LUC-Z17

\* in preparation

Product structure LUC-M40



- Certificate**
- NA version for non-explosion hazardous areas
- EX II 1/2G EEx ia IIC T6
- ES II 1/2D, aluminium cover
- E2 II 1/3D
- SX II 1/2G EEx d (ia) IIC T6
- S2 II 3G EEx nA II T6
- F1 FM IS, Cl. I/II/III, Div.1 Group A-G, N.I .Cl. I, Div.2
- F2 FM XP, Cl. I/II/III, Div. 1, Group A-G
- CG CSA, General Purpose
- C1 CSA IS, Cl. I/II/III, Div. 1, Group A-D, G + coal dust, N.I.
- C2 CSA XP, Cl. I/II/III, Div. 1, Group A-D, G + coal dust, N.I.
- Additional option**
- A basic version
- Sealing sensor/flange**
- 2 Viton
- 3 EPDM
- Display**
- A \* prepared for remote display, order display as accessory LUC-Z40
- B without display
- D with display LUC-Z15 inclusive on-site operation, envelope curve display
- Electrical output**
- AH 4-wire, 90 V AC ... 250 V AC, 4 mA ... 20 mA, HART
- DH 4-wire, 10.5 V DC ... 32 V DC, 4 mA ... 20 mA, HART
- IH 2-wire, 4 mA ... 20 mA, HART
- PA 2-wire, PROFIBUS PA
- Cable entry**
- 2 cable gland M20 x 1.5
- 3 thread G½
- 4 thread ½ NPT
- 5 connector M12, PROFIBUS PA
- Housing**
- A1 aluminium housing F12, IP68, thread M20 x 1.5
- A2 aluminium housing T12, IP68, coated, with separate terminal compartment
- A4 aluminium housing T12, IP68, coated, with separate terminal compartment, overvoltage protection
- Process connection; max. 3 bar abs/44 psia, hole circle PN16/150 lbs/10K**
- P universal flange DN80/ANSI 3"/JIS10K80, PP
- Q universal flange DN80/ANSI 3"/JIS10K80, PVDF
- S universal flange DN80/ANSI 3"/JIS10K80, 1.4535/316L
- T universal flange DN100/ANSI 4"/JIS16K100, PP
- U universal flange DN100/ANSI 4"/JIS16K100, PVDF
- V universal flange DN100/ANSI 4"/JIS16K100, 1.4535/316L
- M mounting bracket LUC-Z17

\* in preparation

Release date 2009-12-21 11:29 Date of issue 2009-12-21 T47789\_ENG.xml