



DeviceNet

Model Number

DSM58

Features

- Industrial standard housing Ø58 mm
- 30 Bit multiturn
- Galvanically isolated DeviceNet interface
- Recessed hollow shaft

Description

In addition to the CANopen, PROFIBUS and AS-Interface rotary encoders, we have broadened our product line of bus-capable absolute encoders with the DSM58 for DeviceNet.

The bus electronics module is integrated into the removable housing cover. This makes it possible to mount or replace the new rotary encoders and the matching bus electronics separately during installation or service.

Absolute encoders deliver an absolute step value for each angle setting. All these values are represented by code samples on one or more code disks. The code disks are screened by an infrared LED and the bit obtained sample is detected by an optical array. Its signals are electronically amplified and are forwarded on to the interface for processing.

The absolute encoder has a maximum basic resolution of 65536 steps per revolution (16 Bits). In the multiturn design, additional up to 16384 revolutions (14 Bits) can be resolved. This results in a total maximum resolution of 1073741824 steps (30 Bits).

The integrated CAN bus interface of the absolute encoder supports all DeviceNet functions. The following operating modes can be programmed, and can be selectively turned on or off:

- Polled mode
- Change of state mode
- Cyclic mode

The absolute encoder is mounted directly onto the application shaft, without any coupling. Rotation of the absolute encoder is prevented by a torque rest.

Technical data

General specifications

Detection type	photoelectric sampling
Device type	Multiturn absolute encoder

Functional safety related parameters

MTTF _d	70 a
Mission Time (T _M)	20 a
L ₁₀	1.9 E+11 at 6000 rpm and 20/40 N axial/radial shaft load
Diagnostic Coverage (DC)	0 %

Electrical specifications

Operating voltage U _B	10 ... 30 V DC
No-load supply current I ₀	max. 230 mA at 10 V DC max. 100 mA at 24 V DC
Time delay before availability t _v	< 250 ms
Linearity	± 2 LSB at 16 Bit, ± 1 LSB at 13 Bit, ± 0,5 LSB at 12 Bit
Output code	binary code
Code course (counting direction)	cw ascending (clockwise rotation, code course ascending) cw descending (clockwise rotation, code course descending)

Interface

Interface type	DeviceNet
Resolution	
Single turn	up to 16 Bit
Multiturn	14 Bit
Overall resolution	up to 30 Bit
Transfer rate	max. 0.5 MBit/s

Connection

Terminal compartment	in removable housing cover
----------------------	----------------------------

Standard conformity

Degree of protection	DIN EN 60529, IP65 IP66 (with shaft seal)
Climatic testing	DIN EN 60068-2-30 , no moisture condensation
Emitted interference	DIN EN 61000-6-4
Noise immunity	DIN EN 61000-6-2
Shock resistance	DIN EN 60068-2-27, 100 g, 6 ms
Vibration resistance	DIN EN 60068-2-6, 20 g, 10 ... 2000 Hz

Ambient conditions

Operating temperature	-40 ... 85 °C (-40 ... 185 °F)
Storage temperature	-40 ... 85 °C (-40 ... 185 °F)

Mechanical specifications

Material	
Combination 1	housing: powder coated aluminum flange: aluminum shaft: stainless steel
Combination 2 (Inox)	housing: stainless steel flange: stainless steel shaft: stainless steel
Mass	approx. 600 g (combination 1) approx. 1200 g (combination 2)
Rotational speed	max. 12000 min ⁻¹
Moment of inertia	30 gcm ²
Starting torque	≤ 3 Ncm (version without shaft seal)
Tightening torque, fastening screws	max. 1.8 Nm
Shaft load	
Angle offset	± 0.9 °
Axial offset	static: ± 0.3 mm, dynamic: ± 0.1 mm
Radial offset	static: ± 0.5 mm, dynamic: ± 0.2 mm

Approvals and certificates

UL approval	cULus Listed, General Purpose, Class 2 Power Source
-------------	---

Release date: 2017-07-06 13:09 Date of issue: 2017-07-06 14:9159_eng.xml

Dimensions

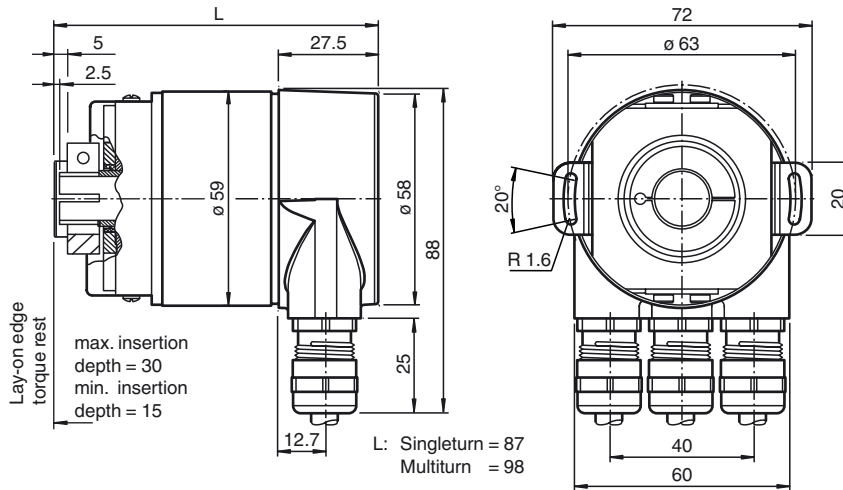

Electrical connection

Terminal	Cable	M12 x 1 Connector	Explanation
⊥	-	-	Ground connection for power supply
(+)	Red	2	Power supply
(-)	Black	3	Power supply
CG	-	1	CAN ground
CL	Blue	5	CAN low
CH	White	4	CAN high
CG	-	-	CAN ground
CL	Blue	-	CAN low
CH	White	-	CAN high

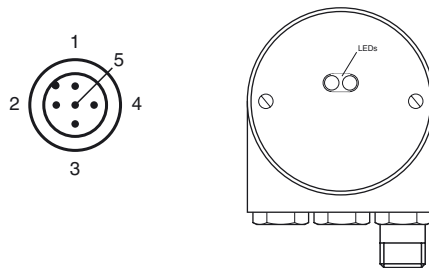

Indicating and operating elements

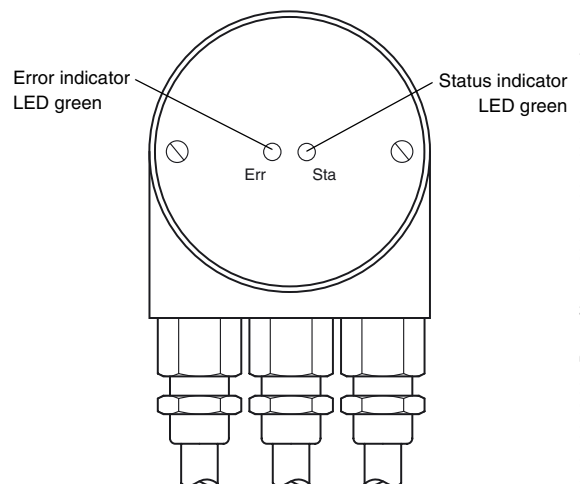
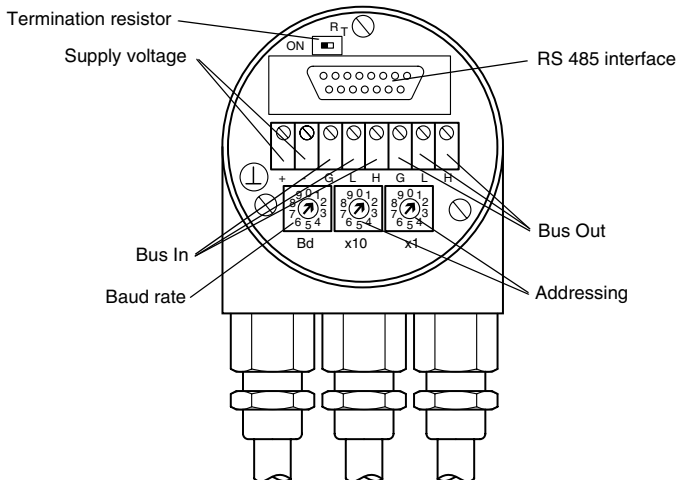

Release date: 2017-07-06 13:09 Date of issue: 2017-07-06 149159_eng.xml

Adjusting the participant address

The participant address can be adjusted with the rotary switches. The address can be defined between 1 and 63, and may only be assigned once.

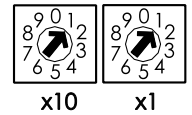

Adjusting the termination resistor

The terminating resistor R_T (121 Ω) can be connected to the circuit by means of the switch:

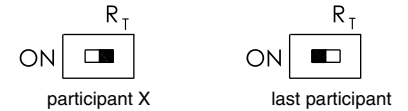

Baud rate adjustment

Baud rate [kBit/s]	Switch position
125	0
250	1
500	2
125	3
reserved	4 ... 9

LED-indicators

LED red	LED green	Meaning
off	off	No voltage supply
off	on	Encoder ready, boot-up message not transmitted, yet. Possible reasons: - no further participant present - wrong baud rate - encoder in prepared status
flashing	on	Boot-up message transmitted, Device configuration possible.
on	on	Normal operation mode, encoder in operational status.

Programmable CAN operating modes

Mode	Explanation
Polled mode	The connected host requests the current actual position value via a telegram. The absolute encoder reads in the current position, calculates all parameters that may have been set and then sends back the actual process value.
Cyclic mode	The absolute encoder sends the current process value depending on a programmable timer. This can cause the bus load to be reduced since the member on the network only sends a message after a specific amount of time without a prompt from the master.
Change of state mode	The absolute encoder monitors the current process value and transfers the current value by itself if there is any change in the value. This can cause the bus load to be reduced, since the member on the network only sends a message if there has been a change.

Programmable rotary encoder parameters

Parameter	Explanation
Operating parameter	The direction of rotation (complement) can be specified by parameter as the operating parameter. This parameter determines the direction of rotation in which the output code will be rising or descending.
Resolution per revolution	The "Resolution" parameter is used to program the rotary encoder so that a desired number of steps can be implemented in reference to a revolution.
Overall resolution	This parameter indicates the desired number of measurement units of the entire travel length. This value must not exceed the overall resolution of the absolute encoder. If the absolute encoder is used in infinite mode, the overall resolution parameter can only take on values that are powers of 2 (2x).
Preset value	The preset value is the desired position value that must be achieved for a specific physical setting of the axis. The preset value parameter is used to set the actual position value to the desired actual process value.

Order code



Number of bits singleturn
 12 4096 (standard)
 13 8192
 16 65536

Number of bits multiturn
 12 4096 (standard)
 14 16384

Option 2
 N Not expanded

Output code
 B Binary

Option 1
 0 No option

Exit position
 R Radial

Connection type
 AG Removable housing cover with terminal compartment
 AN Removable housing cover with connectors M12x1

Shaft dimension/flange version
 F1A Recessed hollow shaft Ø10 mm x 30 mm
 F2A Recessed hollow shaft Ø12 mm x 30 mm
 F3A Recessed hollow shaft Ø15 mm x 30 mm

Housing material
 N Aluminium, powder coated
 I Inox
 W Aluminium, powder coated with shaft seal

Principle of operation
 M Multiturn

Shaft version
 S Recessed hollow shaft

Data format
 D DeviceNet

Release date: 2017-07-06 13:09 Date of issue: 2017-07-06 149159_eng.xml