

## Description



Pizzato Elettrica offers a wide range of products suitable for places where chemical and corrosive agents are used and for aseptic places where particular attention must be paid to cleanliness and hygiene.

The technopolymer housings and external metal parts in stainless steel allow these devices to be used for a variety of applications, ranging from the food and pharmaceutical sectors to the chemical and marine sectors.

## Main features:

- Technopolymer housings
- External metallic parts exclusively in stainless steel
- Protection degree IP67 (FR, FX, FK, FW, FP series switches)
- Protection degree IP67 and IP69K (SR, ST, HX series sensors)

## Resistance against corrosion

Substance	Stainless steel	Technopolymer	Substance	Stainless steel	Technopolymer
Acetylene	■	■	Whisky malt	■	■
Vinegar	■	■	Molasses	■	■
Acetone	■	■	Nickel chloride	□	□
Acetic acid	■	□	Aluminium nitrate	■	■
Boric acid	■	■	Combustible oils	■	■
Citric acid	■	■	Tanning oil	■	-
Hydrochloric acid 100%	□	□	Linseed oil	■	■
Chromic acid 5%	■	□	Hydraulic oil (synthetic)	■	■
Hydrofluoric acid 100%	■	□	Mineral Oil	■	■
Formic acid	■	□	Motor Oil	■	■
Phosphoric acid (<40%)	□	■	Transformer oil	■	■
Lactic acid	■	■	Paraffin	■	■
Nitric acid (concentrated)	■	□	Potassium chloride	■	■
Oleic acid	■	■	Potassium hydroxide (caustic potash)	■	□
Sulphuric acid (<10%)	■	□	Potassium sulphate	■	■
Sulphuric acid (10-75%)	□	□	Propane (liquid)	■	■
Sulphuric acid (75-100%)	□	□	Copper sulphate >5%	■	□
Stearic acid	■	■	Liquid soaps	■	■
Tartaric acid	□	■	Chocolate syrup	■	■
White water	■	■	Milk whey	■	-
Sea water	□	■	Sodium bicarbonate	■	■
Distilled water	■	■	Sodium bisulphate	□	■
White spirit	■	■	Sodium carbonate	■	■
Ethyl alcohol	■	■	Sodium chloride	■	■
Methyl alcohol	■	■	Sodium hydroxide (80%)	■	□
Liquid ammonia	■	■	Sodium hypochlorite (100%)	□	□
Ammonium acetate	■	■	Sodium nitrate	■	■
Ammonium carbonate	■	■	Sodium sulphate	■	■
Ammonium sulfate	■	■	Sodium sulphide	□	■
Leaded petrol	■	■	Aluminium sulphate	■	■
Unleaded petrol	■	■	Ferrous sulphate	■	■
Benzol	■	□	Calcium hydroxide	□	■
Beer	■	■	Potassium hydroxide	■	■
Butane	■	■	Sodium hydroxide	-	■
Butanol	■	■	Tanning solutions	■	■
Quicklime	■	■	Photographic solutions	-	■
Calcium chloride	■	■	Fruit juice	■	■
Calcium hydroxide	■	■	Vegetable juice	■	■
Chloroform	■	■	Toluene	■	□
Aluminium chloride	■	■	Transparent (paint)	■	-
Ferrous chloride	□	□	Trichloroethylene	■	■
Chrome plating	□	□	Whisky and wine	■	■
Diesel	■	■	Zinc plate	□	□
Ether	■	■	Zinc chloride	■	■
Formaldehyde 100%	■	□	Zinc sulphate	-	■
Furfural	■	■	Sulphur chloride	■	■
Gelatine	■	■	Sugar (liquid)	■	■
Glycerine	■	■	Sugar beet	■	■
Glucose	■	■			
Shellac (orange)	■	■			
Hydrogen (gas)	■	■			
Iodine	□	■			
Milk	■	■			
Magnesium chloride	□	■			
Magnesium hydroxide	■	■			
Magnesium sulphate (Epsom salt)	■	■			
Mayonnaise	■	■			

## Resistance against corrosion

- No corrosion
- Possible corrosion
- Corrosion
- Data not available



Contact type

**R** = snap action  
**L** = slow action

Contact block

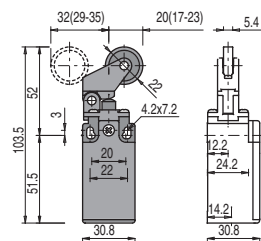
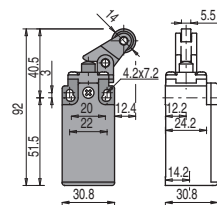
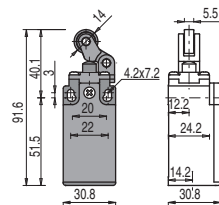
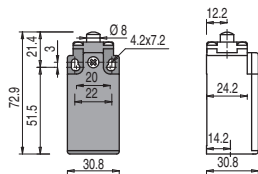

2	<b>R</b>	FR 201-XM2	2x(1NO-1NC)	FR 202-XM2	2x(1NO-1NC)	FR 205-XM2	2x(1NO-1NC)	FR 207-XM2	2x(1NO-1NC)
5	<b>R</b>	FR 501-XM2	1NO+1NC	FR 502-XM2	1NO+1NC	FR 505-XM2	1NO+1NC	FR 507-XM2	1NO+1NC
6	<b>L</b>	FR 601-XM2	1NO+1NC	FR 602-XM2	1NO+1NC	FR 605-XM2	1NO+1NC	FR 607-XM2	1NO+1NC
9	<b>L</b>	FR 901-XM2	2NC	FR 902-XM2	2NC	FR 905-XM2	2NC	FR 907-XM2	2NC
20	<b>L</b>	FR 2001-XM2	1NO+2NC	FR 2002-XM2	1NO+2NC	FR 2005-XM2	1NO+2NC	FR 2007-XM2	1NO+2NC
Max. speed		page 227 - type 4		page 227 - type 3		page 227 - type 3		page 227 - type 3	
Actuating force		8 N (25 N $\rightarrow$ )		6 N (25 N $\rightarrow$ )		6 N (25 N $\rightarrow$ )		4 N (25 N $\rightarrow$ )	
Travel diagrams		page 228 - group 1		page 228 - group 2		page 228 - group 2		page 228 - group 3	

Contact type

**R** = snap action  
**L** = slow action

Contact block

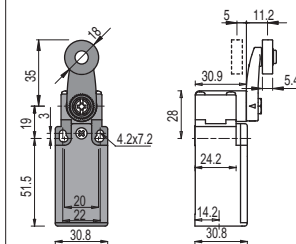
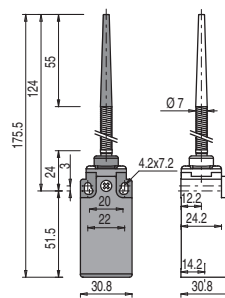
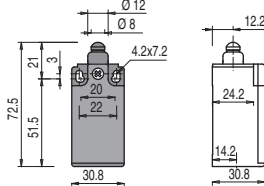
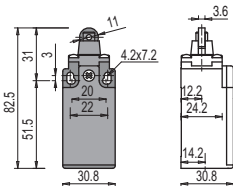

		External gasket		External gasket					
2	<b>R</b>	FR 215-XM2	2x(1NO-1NC)	/	FR 220-XM2	2x(1NO-1NC)	FR 230-XM2V38	2x(1NO-1NC)	
5	<b>R</b>	FR 515-XM2	1NO+1NC	FR 5A1-XM2	1NO+1NC	FR 520-XM2	1NO+1NC	FR 530-XM2V38	1NO+1NC
6	<b>L</b>	FR 615-XM2	1NO+1NC	FR 6A1-XM2	1NO+1NC	/	/	FR 630-XM2V38	1NO+1NC
9	<b>L</b>	FR 915-XM2	2NC	FR 9A1-XM2	2NC	/	/	FR 930-XM2V38	2NC
20	<b>L</b>	FR 2015-XM2	1NO+2NC	FR 20A1-XM2	1NO+2NC	FR 2020-XM2	1NO+2NC	FR 2030-XM2V38	1NO+2NC
Max. speed		page 227 - type 2		page 227 - type 4		1 m/s		page 227 - type 1	
Actuating force		8 N (25 N $\rightarrow$ )		6 N (25 N $\rightarrow$ )		0.07 Nm		0.06 Nm (0.25 Nm $\rightarrow$ )	
Travel diagrams		page 228 - group 1		page 228 - group 1		page 228 - group 4		page 228 - group 5	

Contact type

**R** = snap action  
**L** = slow action

Contact block

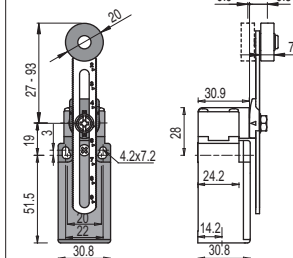
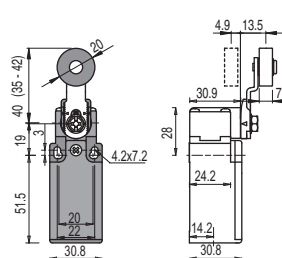
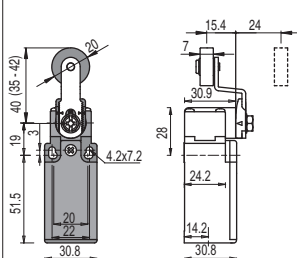
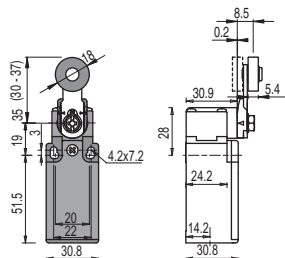

2	<b>R</b>	FR 231-XM2V38	2x(1NO-1NC)	FR 251-XM2V38	2x(1NO-1NC)	FR 254-XM2V38	2x(1NO-1NC)	FR 256-XM2V38	2x(1NO-1NC)
5	<b>R</b>	FR 531-XM2V38	1NO+1NC	FR 551-XM2V38	1NO+1NC	FR 554-XM2V38	1NO+1NC	FR 556-XM2V38	1NO+1NC
6	<b>L</b>	FR 631-XM2V38	1NO+1NC	FR 651-XM2V38	1NO+1NC	FR 654-XM2V38	1NO+1NC	FR 656-XM2V38	1NO+1NC
9	<b>L</b>	FR 931-XM2V38	2NC	FR 951-XM2V38	2NC	FR 954-XM2V38	2NC	FR 956-XM2V38	2NC
20	<b>L</b>	FR 2031-XM2V38	1NO+2NC	FR 2051-XM2V38	1NO+2NC	FR 2054-XM2V38	1NO+2NC	FR 2056-XM2V38	1NO+2NC
Max. speed		page 227 - type 1		page 227 - type 1		page 227 - type 1		page 227 - type 1	
Actuating force		0.06 Nm (0.25 Nm $\rightarrow$ )		0.06 Nm (0.25 Nm $\rightarrow$ )		0.06 Nm (0.25 Nm $\rightarrow$ )		0.06 Nm (0.25 Nm $\rightarrow$ )	
Travel diagrams		page 228 - group 5		page 228 - group 5		page 228 - group 5		page 228 - group 5	

All values in the drawings are in mm

Accessories See page 207

→ The 2D and 3D files are available at [www.pizzato.com](http://www.pizzato.com)

# Switches with external parts in stainless steel

Contact type							
<b>R</b> = snap action							
<b>L</b> = slow action							
Contact block							
2	<b>R</b>	FX 201-XM2	2x(1NO-1NC)	FX 202-XM2	2x(1NO-1NC)	FX 205-XM2	2x(1NO-1NC)
5	<b>R</b>	FX 501-XM2	1NO+1NC	FX 502-XM2	1NO+1NC	FX 505-XM2	1NO+1NC
6	<b>L</b>	FX 601-XM2	1NO+1NC	FX 602-XM2	1NO+1NC	FX 605-XM2	1NO+1NC
9	<b>L</b>	FX 901-XM2	2NC	FX 902-XM2	2NC	FX 905-XM2	2NC
20	<b>L</b>	FX 2001-XM2	1NO+2NC	FX 2002-XM2	1NO+2NC	FX 2005-XM2	1NO+2NC
Max. speed	page 227 - type 4		page 227 - type 3		page 227 - type 3		page 227 - type 3
Actuating force	8 N (25 N $\ominus$ )		6 N (25 N $\ominus$ )		6 N (25 N $\ominus$ )		4 N (25 N $\ominus$ )
Travel diagrams	page 228 - group 1		page 228 - group 2		page 228 - group 2		page 228 - group 3

Contact type				External gasket		External gasket	
<b>R</b> = snap action							
<b>L</b> = slow action							
Contact block							
2	<b>R</b>	FX 215-XM2	2x(1NO-1NC)	FX 220-XM2	2x(1NO-1NC)	FX 225-XM2	2x(1NO-1NC)
5	<b>R</b>	FX 515-XM2	1NO+1NC	FX 520-XM2	1NO+1NC	FX 525-XM2	1NO+1NC
6	<b>L</b>	FX 615-XM2	1NO+1NC	/	/	/	/
9	<b>L</b>	FX 915-XM2	2NC	/	/	/	/
20	<b>L</b>	FX 2015-XM2	1NO+2NC	FX 2020-XM2	1NO+2NC	FX 2025-XM2	1NO+2NC
Max. speed	page 227 - type 2		1 m/s		1 m/s		page 227 - type 1
Actuating force	8 N (25 N $\ominus$ )		0.07 Nm		0.12 Nm		0.06 Nm (0.25 Nm $\ominus$ )
Travel diagrams	page 228 - group 1		page 228 - group 4		page 228 - group 4		page 228 - group 5

Contact type							
<b>R</b> = snap action							
<b>L</b> = slow action							
Contact block							
2	<b>R</b>	FX 231-XM2V38	2x(1NO-1NC)	FX 251-XM2V38	2x(1NO-1NC)	FX 254-XM2V38	2x(1NO-1NC)
5	<b>R</b>	FX 531-XM2V38	1NO+1NC	FX 551-XM2V38	1NO+1NC	FX 554-XM2V38	1NO+1NC
6	<b>L</b>	FX 631-XM2V38	1NO+1NC	FX 651-XM2V38	1NO+1NC	FX 654-XM2V38	1NO+1NC
9	<b>L</b>	FX 931-XM2V38	2NC	FX 951-XM2V38	2NC	FX 954-XM2V38	2NC
20	<b>L</b>	FX 2031-XM2V38	1NO+2NC	FX 2051-XM2V38	1NO+2NC	FX 2054-XM2V38	1NO+2NC
Max. speed	page 227 - type 1		page 227 - type 1		page 227 - type 1		page 227 - type 1
Actuating force	0.06 Nm (0.25 Nm $\ominus$ )		0.06 Nm (0.25 Nm $\ominus$ )		0.06 Nm (0.25 Nm $\ominus$ )		0.06 Nm (0.25 Nm $\ominus$ )
Travel diagrams	page 228 - group 5		page 228 - group 5		page 228 - group 5		page 228 - group 5

All values in the drawings are in mm

Accessories See page 207

→ The 2D and 3D files are available at [www.pizzato.com](http://www.pizzato.com)



Contact type

**R** = snap action  
**L** = slow action

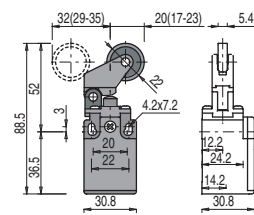
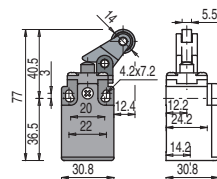
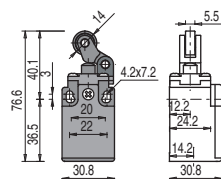
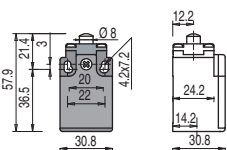

Contact block

3	<b>R</b>	FK 301-XM1	1NO+1NC	FK 302-XM1	1NO+1NC	FK 305-XM1	1NO+1NC	FK 307-XM1	1NO+1NC
33	<b>L</b>	FK 3301-XM1	1NO+1NC	FK 3302-XM1	1NO+1NC	FK 3305-XM1	1NO+1NC	FK 3307-XM1	1NO+1NC
34	<b>L</b>	FK 3401-XM1	2NC	FK 3402-XM1	2NC	FK 3405-XM1	2NC	FK 3407-XM1	2NC
Max. speed		page 227 - type 4		page 227 - type 3		page 227 - type 3		page 227 - type 3	
Actuating force		8 N (25 N)		6 N (25 N)		6 N (25 N)		4 N (25 N)	
Travel diagrams		page 228 - group 1		page 228 - group 2		page 228 - group 2		page 228 - group 3	

Contact type

**R** = snap action  
**L** = slow action

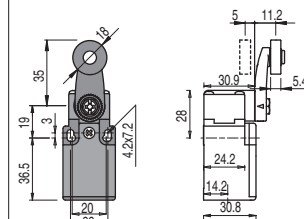
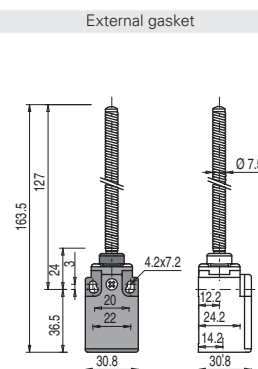
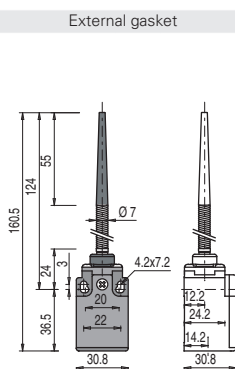
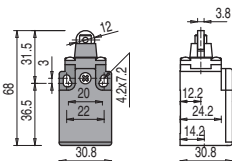

Contact block

3	<b>R</b>	FK 315-XM1	1NO+1NC	FK 320-XM1	1NO-1NC	FK 325-XM1	1NO-1NC	FK 330-XM1V38	1NO+1NC
33	<b>L</b>	FK 3315-XM1	1NO+1NC	FK 3320-XM1	1NO+1NC	FK 3325-XM1	1NO+1NC	FK 3330-XM1V38	1NO+1NC
34	<b>L</b>	FK 3415-XM1	2NC	FK 3420-XM1	2NC	FK 3425-XM1	2NC	FK 3430-XM1V38	2NC
Max. speed		page 227 - type 2		1 m/s		1 m/s		page 227 - type 1	
Actuating force		8 N (25 N)		0.05 Nm		0.1 Nm		0.06 Nm (0.25 Nm)	
Travel diagrams		page 228 - group 1		page 228 - group 4		page 228 - group 4		page 228 - group 5	

Contact type

**R** = snap action  
**L** = slow action

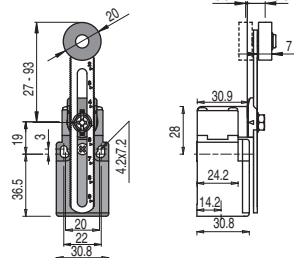
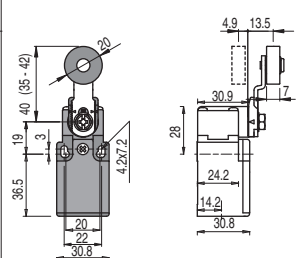
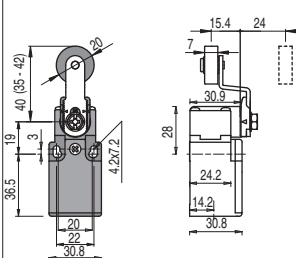
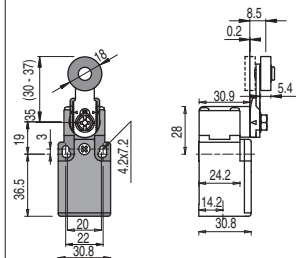

Contact block

3	<b>R</b>	FK 331-XM1V38	1NO+1NC	FK 351-XM1V38	1NO+1NC	FK 354-XM1V38	1NO+1NC	FK 356-XM1V38	1NO+1NC
33	<b>L</b>	FK 3331-XM1V38	1NO+1NC	FK 3351-XM1V38	1NO+1NC	FK 3354-XM1V38	1NO+1NC	FK 3356-XM1V38	1NO+1NC
34	<b>L</b>	FK 3431-XM1V38	2NC	FK 3451-XM1V38	2NC	FK 3454-XM1V38	2NC	FK 3456-XM1V38	2NC
Max. speed		page 227 - type 1		page 227 - type 1		page 227 - type 1		page 227 - type 1	
Actuating force		0.06 Nm (0.25 Nm)		0.06 Nm (0.25 Nm)		0.06 Nm (0.25 Nm)		0.06 Nm (0.25 Nm)	
Travel diagrams		page 228 - group 5		page 228 - group 5		page 228 - group 5		page 228 - group 5	

All values in the drawings are in mm

Accessories See page 207

→ The 2D and 3D files are available at [www.pizzato.com](http://www.pizzato.com)

# Switches with external parts in stainless steel

Contact type:

- R** = snap action
- L** = slow action

Contact block

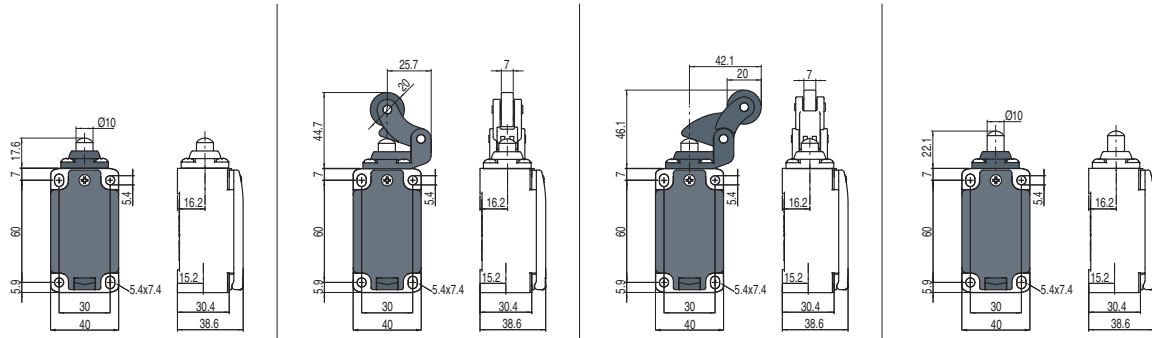

2	<b>R</b>	FP 201-XM2	2x(1NO-1NC)	FP 202-XM2	2x(1NO-1NC)	FP 205-XM2	2x(1NO-1NC)	FP 208-XM2	2x(1NO-1NC)
5	<b>R</b>	FP 501-XM2	1NO+1NC	FP 502-XM2	1NO+1NC	FP 505-XM2	1NO+1NC	FP 508-XM2	1NO+1NC
6	<b>L</b>	FP 601-XM2	1NO+1NC	FP 602-XM2	1NO+1NC	FP 605-XM2	1NO+1NC	FP 608-XM2	1NO+1NC
9	<b>L</b>	FP 901-XM2	2NC	FP 902-XM2	2NC	FP 905-XM2	2NC	FP 908-XM2	2NC
20	<b>L</b>	FP 2001-XM2	1NO+2NC	FP 2002-XM2	1NO+2NC	FP 2005-XM2	1NO+2NC	FP 2008-XM2	1NO+2NC
Max. speed		page 225 - type 4		page 225 - type 3		page 225 - type 3		page 225 - type 4	
Actuating force		8 N (25 N $\rightarrow$ )		6 N (25 N $\rightarrow$ )		6 N (25 N $\rightarrow$ )		8 N (25 N $\rightarrow$ )	
Travel diagrams		page 226 - group 1		page 226 - group 2		page 226 - group 2		page 226 - group 1	

Contact type

- R** = snap action
- L** = slow action

External gasket

Contact block

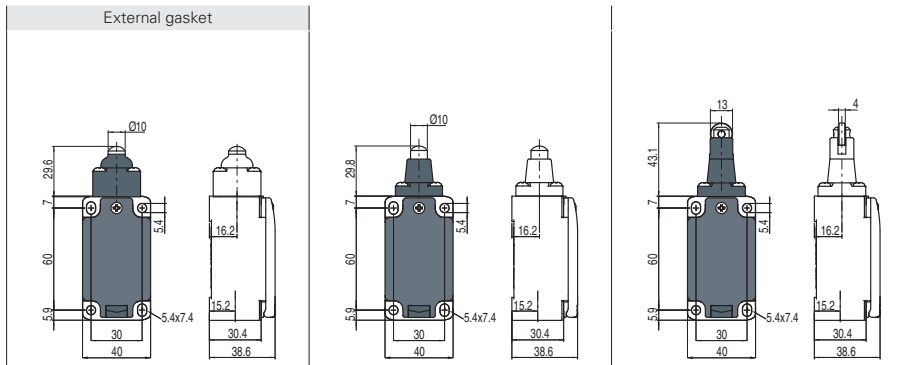

2	<b>R</b>	FP 210-XM2	2x(1NO-1NC)	FP 211-XM2	2x(1NO-1NC)	FP 216-XM2	2x(1NO-1NC)
5	<b>R</b>	FP 510-XM2	1NO+1NC	FP 511-XM2	1NO+1NC	FP 516-XM2	1NO+1NC
6	<b>L</b>	FP 610-XM2	1NO+1NC	FP 611-XM2	1NO+1NC	FP 616-XM2	1NO+1NC
9	<b>L</b>	FP 910-XM2	2NC	FP 911-XM2	2NC	FP 916-XM2	2NC
20	<b>L</b>	FP 2010-XM2	1NO+2NC	FP 2011-XM2	1NO+2NC	FP 2016-XM2	1NO+2NC
Max. speed		page 225 - type 4		page 225 - type 4		page 225 - type 2	
Actuating force		11 N (25 N $\rightarrow$ )		8 N (25 N $\rightarrow$ )		8 N (25 N $\rightarrow$ )	
Travel diagrams		page 226 - group 1		page 226 - group 1		page 226 - group 1	

## Safety switches for hinges

Contact type

- L** = slow action

Contact block

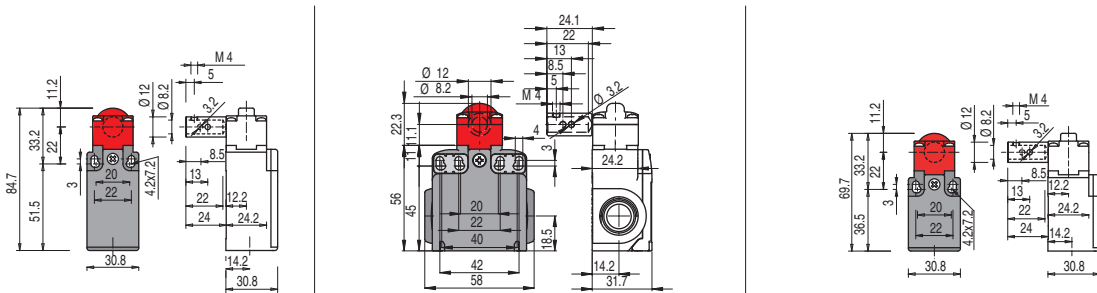

9	<b>L</b>	FR 996-XM2	2NC	FX 996-XM2	2NC	/
18	<b>L</b>	FR 1896-XM2	1NO+1NC	FX 1896-XM2	1NO+1NC	/
20	<b>L</b>	FR 2096-XM2	1NO+2NC	FX 2096-XM2	1NO+2NC	/
33	<b>L</b>	/	/	/	/	FK 3396-XM1
34	<b>L</b>	/	/	/	/	FK 3496-XM1
Actuating force		0.15 Nm (0.4 Nm $\rightarrow$ )		0.15 Nm (0.4 Nm $\rightarrow$ )		0.15 Nm (0.4 Nm $\rightarrow$ )
Travel diagrams		page 230 - group 9		page 230 - group 9		page 230 - group 9

**⚠ If not expressly indicated in this chapter, for correct installation and utilization of all articles see the instructions given on pages 223 to 236.**

### Safety switches with separate actuator

Contact type  
**R** = snap action  
**L** = slow action

	Without actuator	Without actuator	Without actuator	Without actuator
6				
9				
20				
33				
34				
Actuating force	10 N (18 N $\ominus$ )	10 N (18 N $\ominus$ )	10 N (18 N $\ominus$ )	10 N (18 N $\ominus$ )
Travel diagrams	page 230 - group 8	page 230 - group 8	page 230 - group 8	page 230 - group 8

### Stainless steel actuators

**IMPORTANT:** These actuators can be used only with items of the FR, FX, FK and FW series (e.g. FR 693-XM2).  
 Low level of coding acc. to EN ISO 14119.

Article	Description	Article	Description
VF KEYD	Straight actuator	VF KEYD1	Angled actuator
VF KEYD5	Extended actuator	VF KEYD6	Extended actuator, angled
VF KEYD8	Universal actuator	VF KEYD10	Profiled actuator

### SR series magnetic safety sensors



See page 27 and 33,  
 General Catalogue Safety 2019-2020

### ST series safety sensors with RFID technology



See page 39,  
 General Catalogue Safety 2019-2020

### HX series stainless steel safety switches



See page 59,  
 General Catalogue Safety 2019-2020

All values in the drawings are in mm

Accessories See page 207

→ The 2D and 3D files are available at [www.pizzato.com](http://www.pizzato.com)