

## Datasheet - EX-T4VH 335-03Z-3G/D



Position switches with safety function / EX-335 Metal enclosure with Actuator / EX-335 Roller lever H



(Minor differences between the printed image and the original product may exist!)

- Explosion protection for ATEX Zones 2 and 22
- Metal enclosure
- Wide range of alternative actuators
- Good resistance to oil and petroleum spirit
- 40,5 mm x 76 mm x 38 mm
- Actuator heads can be repositioned by 4 x 90°
- Ex-certified screwed cable gland
- Mounting details to EN 50041
- 1 Cable entry M 20 x 1.5
- Ex certified

### Ordering details

Product type description	EX-T4VH 335-03Z-3G/D
Article number	EX-T4VH 335-03Z-3G/D
EAN Code	
eCl@ss	27-27-26-01

### Approval

Approval	ATEX
----------	------

### Classification

Standards	EN ISO 13849-1
B10d Normally-closed contact (NC)	20.000.000
Mission time	20 Years
notice	$MTTF_d = \frac{B_{10d}}{0,1 \times n_{op}}$ $n_{op} = \frac{d_{ap} \times h_{cp} \times 3600 \text{ s/h}}{t_{cycle}}$

### Global Properties

Permanent light	EX-T 335 Rollenschwenkhebel H
Standards	EN 60079-0, EN 60079-15, EN 60079-31, EN 60947-5-1, BG-GS-ET-15
Compliance with the Directives (Y/N)	Yes

Suitable for safety functions (Y/N)	Yes
Actuator type	A to EN 50041
Materials	
- Material of the housings	Aluminium
- Lever material	Metal film
- Roller material	Plastic
- Material of the contacts	Silver
Housing coating	painted
Housing construction form	Norm construction design
Weight	

## Mechanical data

---

Design of electrical connection	Screw connection
Cable cross-section of the cable glands	
- Min. Cable cross-section of the cable glands	7
- Max. Cable cross-section of the cable glands	12
Cable section	
- Min. Cable section	0,75
- Max. Cable section	2.5
AWG-Number	13
Mechanical life	30.000.000 operations
Switching frequency	max. 5000 /h
notice	All indications about the cable section are including the conductor ferrules.
Design of actuating element	Roller lever
actuating torque	min. 31 Ncm
Bounce duration	< 2
Switchover time	in accordance with actuating speed
Impact energy	max. 4 J
Actuating speed with actuating angle 30° to switch axis	
- Min. Actuating speed	
- Max. Actuating speed	2.5 m/s

## Ambient conditions

---

Ambient temperature	
- Min. environmental temperature	-20
- Max. environmental temperature	+60
Protection class	IP67

## Electrical data

---

Design of control element	Opener (NC)
Switching principle	Slow action
- positive break NC contact 	
Number of auxiliary contacts	0
Number of safety contacts	3
Rated impulse withstand voltage $U_{imp}$	4 kV
Rated insulation voltage $U_i$	250 V
Thermal test current $I_{the}$	10 A
Utilisation category	AC-15: 230 V / 4 A, DC-13: 24 V / 1 A
Max. fuse rating	6 A gG D-fuse

## ATEX

EX-marking	EX II 3D Ex tc IIIC T90°C Dc X EX II 3G Ex nC IIC T5 Gc X
Explosion protection categories for gases	3G
Explosion protection Zones for gases	2
Explosion protected category for dusts	3D
Explosion protection Zones for dusts	22

## Dimensions

Dimensions of the sensor	
- Width of sensor	40.5
- Height of sensor	134
- Length of sensor	60.55

## Keywords

Keywords	Ex, EEx, ATEX, Ex 235, Ex 235, 235 Ex, 235ex, 235ex, ATEX 235
----------	---

## Diagram

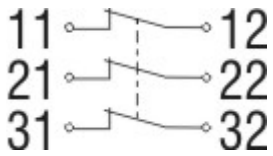

Note Diagram

- positive break NC contact
- active
- no active
- Normally-open contact
- Normally-closed contact

## Switch travel diagram

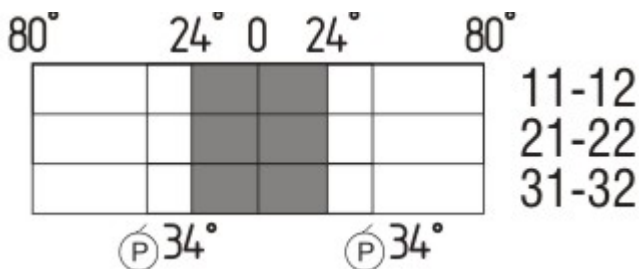

Notes Switch travel diagram

- Contact closed
- Contact open
- Setting range
- Break point
- Positive opening sequence/- angle
- VS** adjustable range of NO contact
- VÖ** adjustable range of NC contact
- N** after travel

## Ordering suffix

---

The applicable ordering suffix is added at the end of the part number of the safety switch.

Order example: EX-T4VH 335-03Z-3G/D-**RMS**

...-RMS	Available with metal roller
...-1H	Roller material : Plastic Durchmesser : 25 mm
...-1297	Enclosure with transverse slotted holes
...-1637	0,3 µm gold-plated contacts

## Ordering code

---

EX-(1)(2) 335-(3)Z(4)-(5)-(6)-(7)-3G/D

(1)	
Z	Snap action
T	Slow action
(2)	
S	Plunger S
R	Roller plunger R
H	Roller lever H
10H	Rod lever 10H
7H	Roller lever 7H
7H-2138	Roller lever 7H for Position switches with safety function
1K	Offset roller lever 1K
3K	Angle roller lever 3K
(3)	
11	1 Normally open contact (NO) / 1 Opener (NC)
02	2 Opener (NC)
20	2 Normally open contact (NO) ( <i>Switch with 2 NO contacts are not for security tasks</i> )
01/01	1 Opener (NC) left / 1 Opener (NC) right
12	1 Normally open contact (NO) / 2 Opener (NC)
03	3 Opener (NC)
(4)	
H	Slow action with staggered contacts
UE	Slow action with overlapping contacts
(5)	
1297	Enclosure with transverse slotted holes
(6)	
2138	Roller lever 7H for Position switches with safety function
(7)	
1637	gold-plated contacts

## Documents

---

Code: mrl\_ex-zt335-3gd\_jp

**Operating instructions and Declaration of conformity (de)** 303 kB, 16.08.2018

Code: mrl\_ex-zt335-3gd\_de

**Operating instructions and Declaration of conformity (it)** 339 kB, 27.08.2018

Code: mrl\_ex-zt335-3gd\_it

**Operating instructions and Declaration of conformity (en)** 354 kB, 16.08.2018

Code: mrl\_ex-zt335-3gd\_en

**Operating instructions and Declaration of conformity (pt)** 361 kB, 27.08.2018

Code: mrl\_ex-zt335-3gd\_pt

**Operating instructions and Declaration of conformity (fr)** 359 kB, 27.08.2018

Code: mrl\_ex-zt335-3gd\_fr

**Operating instructions and Declaration of conformity (pl)** 394 kB, 27.08.2018

Code: mrl\_ex-zt335-3gd\_pl

**Operating instructions and Declaration of conformity (es)** 357 kB, 27.08.2018

Code: mrl\_ex-zt335-3gd\_es

**Operating instructions and Declaration of conformity (nl)** 356 kB, 27.08.2018

Code: mrl\_ex-zt335-3gd\_nl

**Brochure (de)** 7 MB, 19.10.2016

Code: b\_atep01\_de

**Brochure (en)** 7 MB, 19.10.2016

Code: b\_atep01\_en

**Brochure (it)** 3 MB, 20.07.2007

Code: b\_atep05

**Brochure (es)** 5 MB, 18.08.2009

Code: b\_atep09

## Images

---

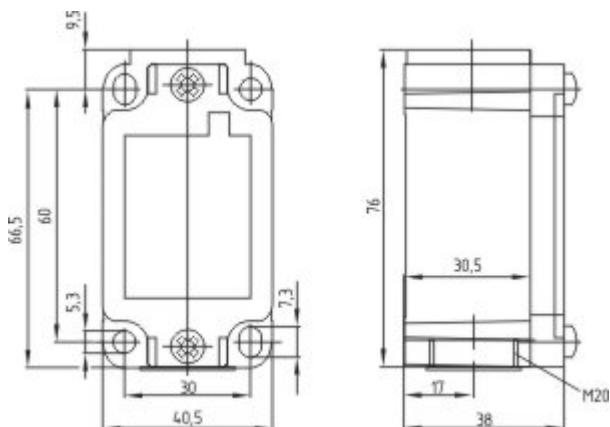

Dimensional drawing (basic component)

---

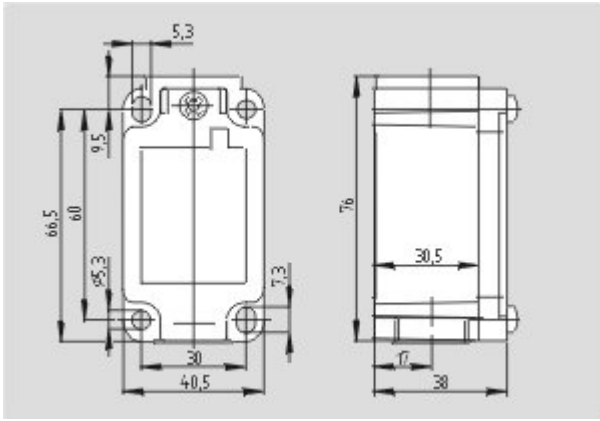

Dimensional drawing (basic component)

---

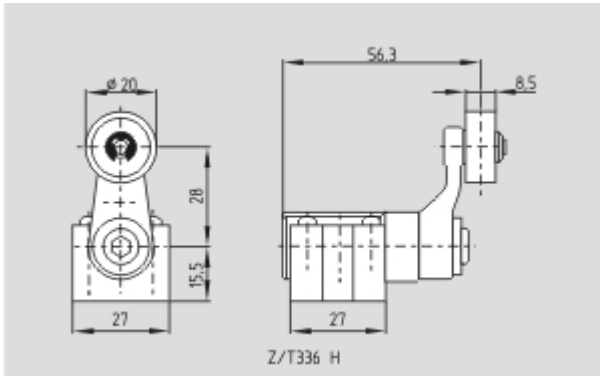

Dimensional drawing (actuator)

---

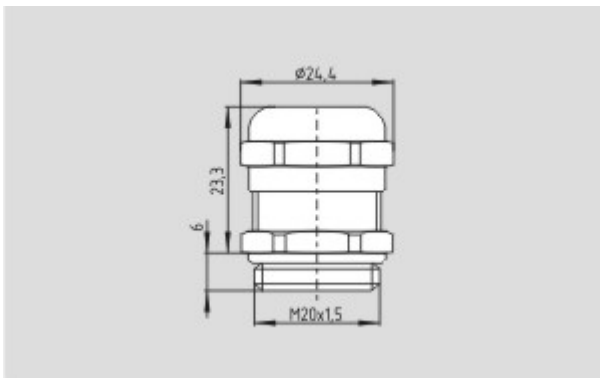

Dimensional drawing (miscellaneous)

---