

Datasheet - TV8S 355-03Z

Safety switch for hinged guards / Hinge safety switch / TV.S 355



- Metal enclosure
- Good resistance to oil and petroleum spirit
- Actuator heads can be repositioned by 4 x 90°
- 66,7 mm x 107 mm x 65,3 mm
- Actuator shaft can be turned 360°
- 3 Cable entry M 20 x 1.5

(Minor differences between the printed image and the original product may exist!)

Ordering details

Product type description	TV8S 355-03Z
Article number	101179255
EAN Code	4030661311739
eCl@ss	27-27-26-01

Approval

Approval

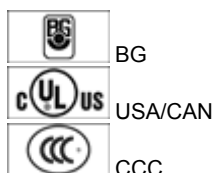

Classification

Standards	EN ISO 13849-1
B10d Normally-closed contact (NC)	20.000.000
Mission time notice	20 Years

$$MTTF_d = \frac{B_{rod}}{0,1 \times n_{op}}$$

$$n_{op} = \frac{d_{op} \times h_{op} \times 3600 \text{ s/h}}{t_{cycle}}$$

Global Properties

Permanent light	TV.S 355
Standards	EN 60947-5-1, BG-GS-ET-15
Compliance with the Directives (Y/N) 	Yes
Materials	
- Material of the housings	Aluminium
- Material of the contacts	Silver
Housing coating	painted
Weight	315

Mechanical data

Design of electrical connection	Screw connection
Cable entry M 20 x 1.5	3
Cable section	
- Min. Cable section	0,75
- Max. Cable section	2.5
Design of actuating element	Other
Mechanical life	> 1.000.000 operations
Switching frequency	max. 1000 /h
notice	All indications about the cable section are including the conductor ferrules.
Shaft bore	Ø 8
Positive break angle	7 °
Positive break torque	60 Ncm

Ambient conditions

Ambient temperature	
- Min. environmental temperature	-25 °C
- Max. environmental temperature	+70 °C
Protection class	IP67

Electrical data

Design of control element	Opener (NC)
Switching principle	Creep circuit element
Number of auxiliary contacts	0
Number of safety contacts	3
Rated impulse withstand voltage U_{imp}	4 kV
Rated insulation voltage U_i	250 V
Thermal test current I_{the}	10 A
Utilisation category	AC-15: 230 V / 4 A, DC-13: 24 V / 4 A
Max. fuse rating	6 A gG D-fuse

ATEX

Explosion protection categories for gases	None
Explosion protected category for dusts	None

Dimensions

Dimensions of the sensor

- Width of sensor	66.7 mm
- Height of sensor	107 mm
- Length of sensor	65.3 mm

notice

Setting assistance

Grub screw for location, shaft pre-drilled for pin

Universal joint available to compensate for axial displacement (only for shaft bore 10 mm)

By turning the head in 90° steps, 8 actuating planes are possible. A Torx T10 screwdriver is needed for this purpose. Even when the screw is removed, the head is self-retaining. The switch can still not be tampered.

Diagram

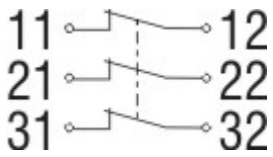

Note Diagram

- positive break NC contact
- active
- no active
- Normally-open contact
- Normally-closed contact

Switch travel diagram

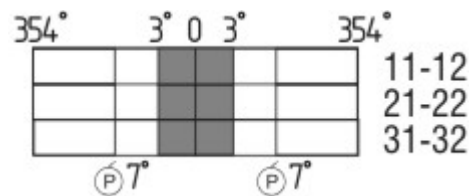

Notes Switch travel diagram

- Contact closed
- Contact open
- Setting range
- Break point
- Positive opening sequence/- angle
- VS** adjustable range of NO contact
- VÖ** adjustable range of NC contact
- N** after travel

Ordering suffix

The applicable ordering suffix is added at the end of the part number of the safety switch.

Order example: TV8S 355-03Z-NPT

...-NPT

Cable entry NPT 1/2"

Ordering code

TV(1)S 355-(2)Z-(3)

(1)

8 Shaft bore Ø 8 mm
10 Shaft bore Ø 10 mm

(2)

02 2 Opener (NC)
03 3 Opener (NC)
11 1 Normally open contact (NO) / 1 Opener (NC)
12 1 Normally open contact (NO) / 2 Opener (NC)

(3)

without Cable entry M20
NPT cable entry NPT 1/2"
ST M12 connector with A-coding (*Caution! The versions with connector may only be used in PELV circuits to EN 60204-1.*)
ST-2310 M12 connector with B-coding (*Caution! The versions with connector may only be used in PELV circuits to EN 60204-1.*)
G24 with LED (*only available for version with one NO and one NC contact.*)

Documents

Operating instructions and Declaration of conformity (de) 285 kB, 29.03.2017

Code: mrl_tvs335-355_de

Operating instructions and Declaration of conformity (fr) 285 kB, 11.05.2017

Code: mrl_tvs335-355_fr

Operating instructions and Declaration of conformity (es) 281 kB, 03.05.2017

Code: mrl_tvs335-355_es

Operating instructions and Declaration of conformity (jp) 420 kB, 29.11.2017

Code: mrl_tvs335-355_jp

Operating instructions and Declaration of conformity (nl) 312 kB, 05.07.2018

Code: mrl_tvs335-355_nl

Operating instructions and Declaration of conformity (it) 281 kB, 26.06.2017

Code: mrl_tvs335-355_it

Operating instructions and Declaration of conformity (en) 281 kB, 29.03.2017

Code: mrl_tvs335-355_en

Operating instructions and Declaration of conformity (da) 263 kB, 18.06.2013

Code: mrl_tvs335-355_da

Operating instructions and Declaration of conformity (pt) 283 kB, 10.05.2017

Code: mrl_tvs335-355_pt

Operating instructions and Declaration of conformity (pl) 313 kB, 17.07.2017

Code: mrl_tvs335-355_pl

BG-test certificate (en) 166 kB, 09.12.2015

Code: z_tvsp02

BG-test certificate (de) 160 kB, 09.12.2015

Code: z_tvsp01

CCC certification (en) 577 kB, 12.12.2006

Code: q_349p02

CCC certification (cn) 609 kB, 12.12.2006

Code: q_349p03

Images

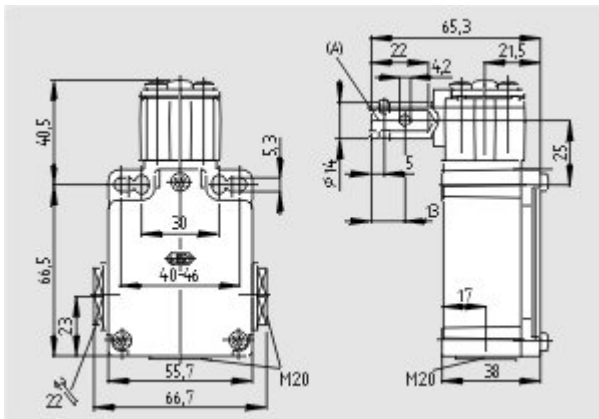

Dimensional drawing (basic component)

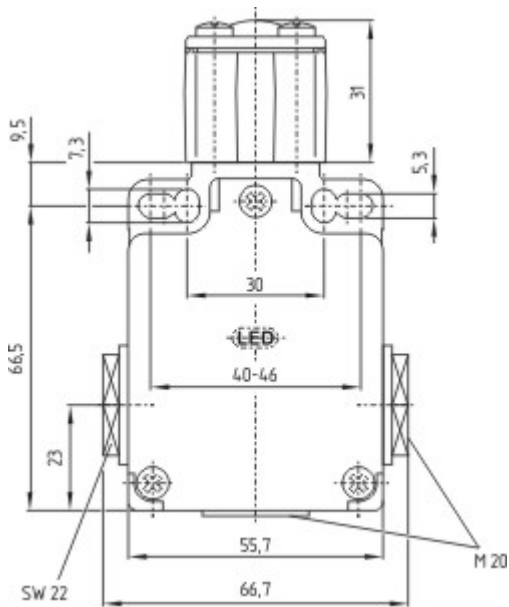

Dimensional drawing (basic component)

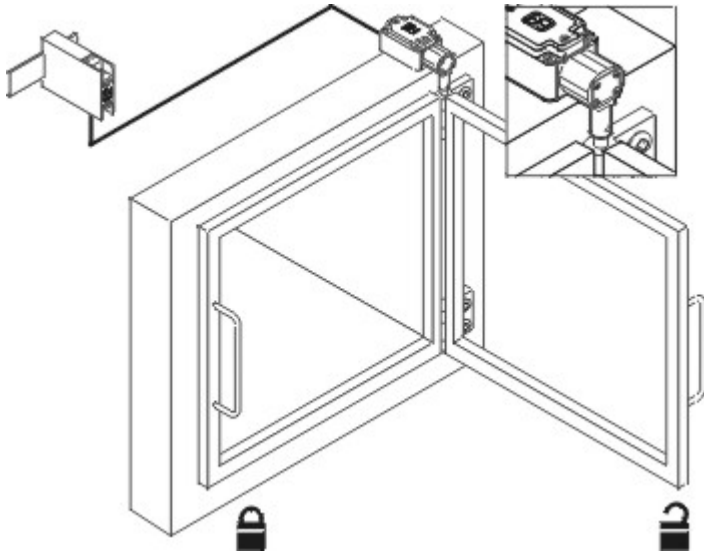

Application

K.A. Schmersal GmbH & Co. KG, Möddinghofe 30, D-42279 Wuppertal

The data and values have been checked thoroughly. Technical modifications and errors excepted.

Generiert am 13.02.2019 - 14:34:33h Kasbase 3.3.0.F.64I