

## Datasheet - BN 310-01Z

Magnetic reed switch / BN 310



Preferred typ



(Minor differences between the printed image and the original product may exist!)

- Non-contact principle
- 1 Reed kontakts
- Actuation from side
- Flat design
- Actuating surface and direction of actuation marked by switch symbol
- 88 mm x 25 mm x 13 mm
- Thermoplastic enclosure
- Actuating distance up to 60 mm depending on actuating magnet and version

### Ordering details

Product type description	BN 310-01Z
Article number	101133844
EAN Code	4030661059433
eCl@ss	27-27-01-04

### Approval

Approval



### Global Properties

Permanent light	BN 310
Standards	-
Compliance with the Directives (Y/N) 	Yes
suitable for elevators (Y/N)	Yes
Mounting	Enclosure with mounting slots
Active principle	Magnetic drive
Materials	
- Material of the housings	Plastic, glass-fibre reinforced thermoplastic
- Material of the cable mantle	H03VV-F
Housing construction form	rectangular, flat
Weight	75
Recommended actuator	BP 10; 2 x BP 10; BP 15; 2 x BP 15; 2 x BP 15/2; BP 34; BP 20; BP 31; BP 11; BP 12; BP 21; BE 20
- Lift switchgear	BP 10, 2 x BP 10, 2 x BP 15/2, BP 15, 2 x BP 15, BP 34

### Mechanical data

Design of electrical connection	Cable
Cable length	1
Conductors	2 x 0,75
AWG-Number	18

Mechanical life	1.000.000.000 operations
Electrical lifetime	1.000.000 ... 1.000.000.000 operations
Actuating planes	Actuation from side
Switch distance	5 ... 50 BP 10 = 5 mm 2 x BP 10 = 17 mm BP 15 = 6 mm 2 x BP 15 = 17 mm 2 x BP 15/2 = 17 mm BP 34 = 5 ... 20 mm BP 20 = 20 mm BP 31 = 20 mm BP 11 = 8 ... 20 mm BP 12 = 10 ... 30 mm BP 21 = 25 ... 50 mm BE 20 = 20 mm
- notice	Actuating distance up to 50 mm depending on actuating magnet and version  The specifications with regard to the switching distances apply to the actuation of the individually mounted devices without ferromagnetic influence. Any change of the distance, positive either negative, is possible due to ferromagnetic interference. When multiple actuating magnets are used, the mutual interference must be observed.
Type of actuation	Magnet
restistance to shock	30 / 11
Resistance to vibration	10 ... 55 HZ, Amplitude 1 mm
Bounce duration	0,3 ... 0,6
Latching (Y/N)	No
Actuating speed	18
Switching point accuracy	± 0,25 mm

## Ambient conditions

---

Ambient temperature	
- Min. environmental temperature	-25
- Max. environmental temperature	+75
Protection class	IP67 to IEC/EN 60529

## Electrical data

---

Design of control element	Opener (NC)
Number of shutters	0
Number of openers	1
Switching time - Close	-
Switching time - Open	0,5
Switch frequency	< 300
Dielectric strength	> 600 (50 )
Switching voltage	250
Switching current	3 A
Switching capacity	120 /

## Outputs

---

Design of control output	Reed kontakts
--------------------------	---------------

## LED switching conditions display

---

LED switching conditions display (Y/N)

No

## ATEX

---

Explosion protection categories for gases

None

Explosion protected category for dusts

None

## Dimensions

---

Dimensions of the sensor

- Width of sensor	88
- Height of sensor	25
- Length of sensor	13

## notice

---

The opening and closing functions depend on the direction of actuation, the actuating magnets and the polarity of the actuating magnets.

When the switches and actuators come together, the colours must coincide: Red (S) to red (S) and green (N) to green (N). This does not apply to the bistable contact.

The switch is to be mounted on iron with a non-magnetic layer of at least 20 mm.

## Included in delivery

---



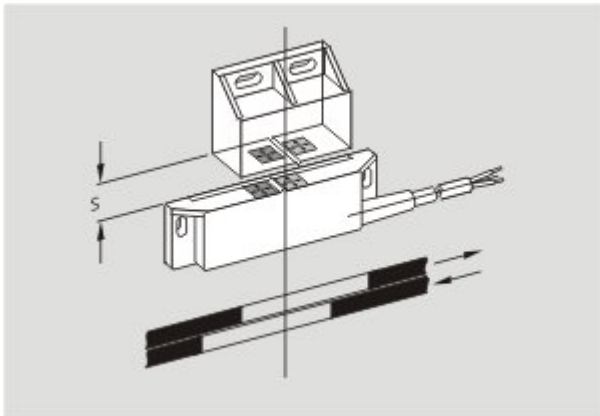

Actuators must be ordered separately.

## Diagram

---



Note Diagram

-  positive break NC contact
-  active
-  no active
-  Normally-open contact
-  Normally-closed contact

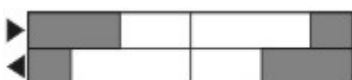

## Switch travel diagram

---



Notes Switch travel diagram

-  Contact closed

- Contact open
  - Setting range
  -  Break point
  -  Positive opening sequence/- angle
- VS** adjustable range of NO contact  
**VÖ** adjustable range of NC contact  
**N** after travel

## Ordering suffix

---

*The applicable ordering suffix is added at the end of the part number of the safety switch.*  
Order example: BN 310-01Z-**5M**

...-**5M** Cable length 5 Meter

...-**10M** Cable length 10 m

## Documents

---

**Declaration of conformity** (en) 186 kB, 12.07.2018

Code: \_\_bn\_p01\_en

**Declaration of conformity** (de) 102 kB, 08.06.2016

Code: \_\_bn\_p01

**notice - Switch distance** (de) 36 kB, 07.08.2009

Code: s\_bnbsp01

**notice - Switch distance** (nl) 39 kB, 07.08.2009

Code: s\_bnbsp04

**notice - Switch distance** (en) 42 kB, 07.08.2009

Code: s\_bnbsp02

**notice - Switch distance** (fr) 41 kB, 07.08.2009

Code: s\_bnbsp03

**notice - Switch distance** (pt) 39 kB, 07.08.2009

Code: s\_bnbsp10

**notice - Switch distance** (it) 40 kB, 07.08.2009

Code: s\_bnbsp05

**notice - Switch distance** (es) 38 kB, 07.08.2009

Code: s\_bnbsp09

## Images

---

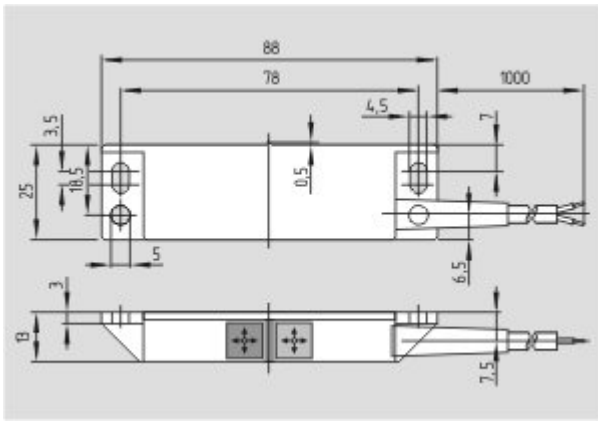

Dimensional drawing (basic component)

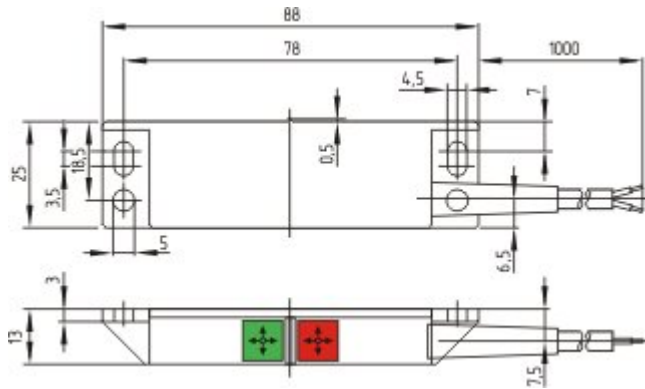

Dimensional drawing (basic component)

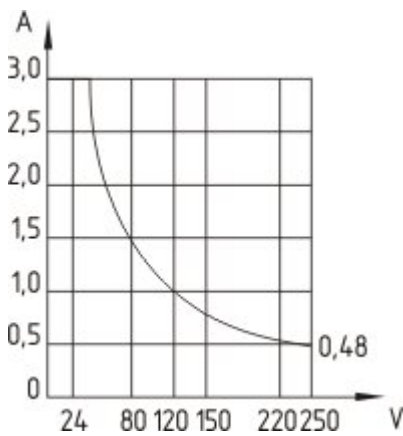

Characteristic curve