

Datasheet - AV 15RHX30U 45 GR.N

Door locking devices / AV 15



(Minor differences between the printed image and the original product may exist!)

- right-hand model
- for 1-leaf doors
- Fail-safe locking system
- Metal enclosure
- authorised for use in passenger elevators
- Manual release by means of M5 triangular key

Ordering details

Product type description	AV 15RHX30U 45 GR.N
Article number	101082731
EAN Code	4030661012353
eCl@ss	27-27-26-03

Approval

Approval



Global Properties

Permanent light	AV 15
Standards	EN 81-20, EN 81-50
Compliance with the Directives (Y/N) 	Yes
Suitable for safety functions (Y/N)	Yes
Mounting	rear-side mounting holes
Number of door leaves	1
Materials	
- Material of the housings	light alloy die-casting
- Material of the contacts	Silver
- Locking bolt material	Brass
Weight	880
Latching bolt bevelling	45 bottom

Mechanical data

Cable entry	without cable gland
notice	Graphic representation: left-hand model mirror image
Design of actuating element	Offset roller lever H65
Orientation / Alignment	right-hand model

With fail-safe locking system (Y/N)	Yes
Manual release (Y/N)	Yes
Permanent magnet	Ceramic oxide magnet with high coercive field strength

Ambient conditions

Ambient temperature	
- Min. environmental temperature	-15
- Max. environmental temperature	+70
Protection class	IP20

Electrical data

Design of control element	Opener (NC)
Switching principle	Slow action
- positive break NC contact 	
Number of auxiliary contacts	0
Number of safety contacts	1
Rated impulse withstand voltage	6
Rated insulation voltage	400
Thermal test current	10 A
Utilisation category	AC-15: 230 V / 2 A, DC-13: 200 V / 2 A
Max. fuse rating	6 A (slow blow)

Dimensions

Dimensions	
- Width	165
- Height	80
- Depth	36
Dimensions of the latching bolt	
- Diameter of the latching bolt	18
- X-dimension of the latching bolt	30

notice **X-dimension of the latching bolt:**
The overall latching bolt length is the result of the prescribed insertion depth of the latching bolt into the door leaf of 21 mm and the X-dimension. The X-dimension is the distance between the enclosure bottom of the door locking and the door top.

Accessories

notice	Manual release using triangular key M5 available as accessory
notice	Solenoid SOL-AV15/AV18 for electrical actuation available as accessory

Ordering suffix

The applicable ordering suffix is added at the end of the part number of the safety switch.
Order example: AV 15RHX30U 45 GR.N-K

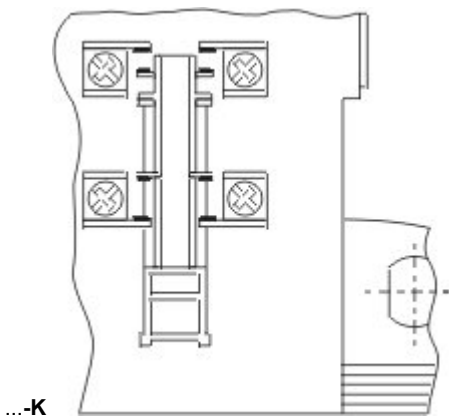

The auxiliary contact K shows the top position of the switch. This enables detecting which guard is unlocked. It is always the top contact.

...-GB215

additional front-side M8 mounting holes

Ordering code

AV 15(1)(2)(3)(4)(5)(6)(7) 45 GR.N(8)

(1)

L left-hand model
R right-hand model

(2)

without

H Roller H65
H92 Roller H92
H105 Roller H105
B Bearing block B
B2 Bearing block B2

(3)

without without Auxiliary contact
K with Auxiliary contact

(4)

without Protection class IP20
IP41 Protection class IP41

(5)

without without cable gland
E4 cable gland M20
E1 Cable entry

(6)

X... = 11, 5, 20, 30, 40, 45 mm

(7)

U 45° bottom
D 45° cover-side
L/R 45° 1 x left / 1 x right,

(8)

GB215

Documents

Operating instructions and Declaration of conformity (nl) 435 kB, 26.06.2018

Code: mrl_av15_nl

Operating instructions and Declaration of conformity (pt) 419 kB, 08.03.2017

Code: mrl_av15_pt

Operating instructions and Declaration of conformity (pl) 433 kB, 17.02.2017

Code: mrl_av15_pl

Operating instructions and Declaration of conformity (de) 404 kB, 06.12.2016

Code: mrl_av15_de

Operating instructions and Declaration of conformity (es) 418 kB, 12.01.2017

Code: mrl_av15_es

Operating instructions and Declaration of conformity (cn) 501 kB, 11.05.2017

Code: mrl_av15_cn

Operating instructions and Declaration of conformity (en) 616 kB, 18.10.2016

Code: mrl_av15_en

Operating instructions and Declaration of conformity (it) 418 kB, 12.01.2017

Code: mrl_av15_it

Operating instructions and Declaration of conformity (fr) 422 kB, 12.01.2017

Code: mrl_av15_fr

Operating instructions and Declaration of conformity (jp) 506 kB, 22.08.2017

Code: mrl_av15_jp

BG-test certificate (de) 247 kB, 12.05.2016

Code: _av15p01

BG-test certificate (en) 239 kB, 12.05.2016

Code: _av15p02

CCC certification (en) 2 MB, 29.10.2018

Code: q_av1p02

CCC certification (cn) 2 MB, 29.10.2018

Code: q_av1p03

EAC certification (ru) 2 MB, 03.12.2018

Code: q_0010p17_ru

notice (es) 1 MB, 09.02.2012

Code: s_aufp01_es

notice (en) 487 kB, 09.02.2012

Code: s_aufp01_en

notice (fr) 1 MB, 09.02.2012

Code: s_aufp01_fr

notice (it) 1 MB, 09.02.2012

Code: s_aufp01_it

notice (de) 1 MB, 09.02.2012

Images

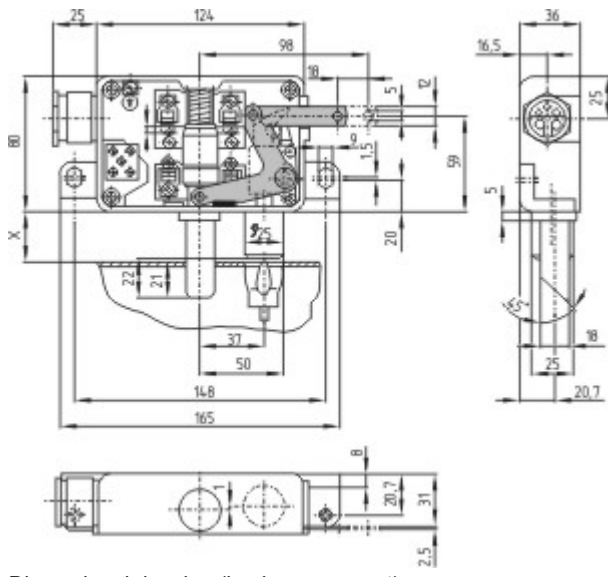

Dimensional drawing (basic component)

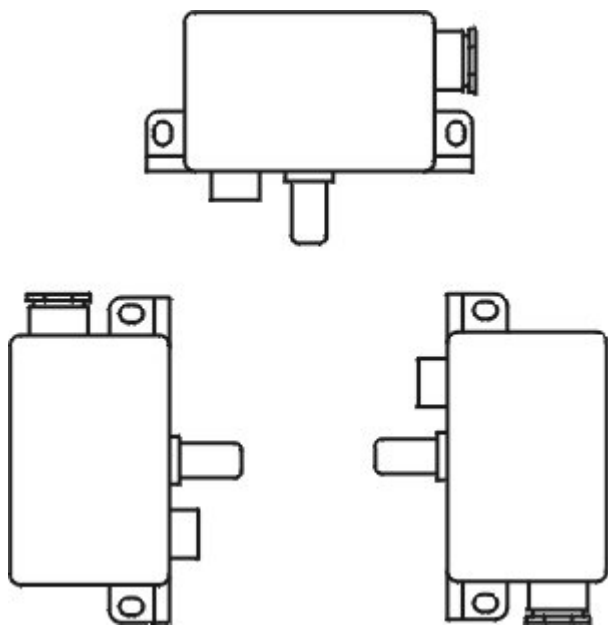

Assembly example

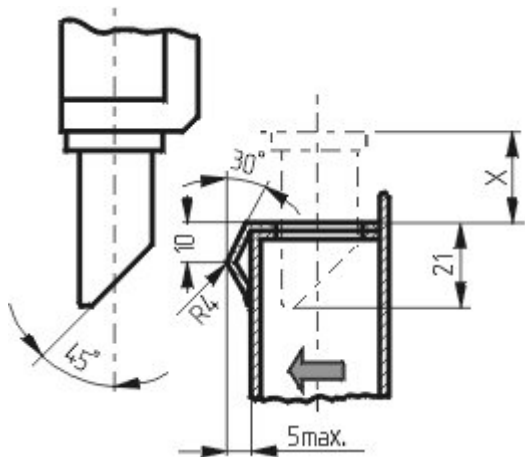

Assembly example

K.A. Schmersal GmbH & Co. KG, Möddinghofe 30, D-42279 Wuppertal

The data and values have been checked thoroughly. Technical modifications and errors excepted.

Generiert am 13.02.2019 - 12:59:29h Kasbase 3.3.0.F.64I