

## Datasheet - NST 20-8

Safety light barriers / Accessories / Mounting post

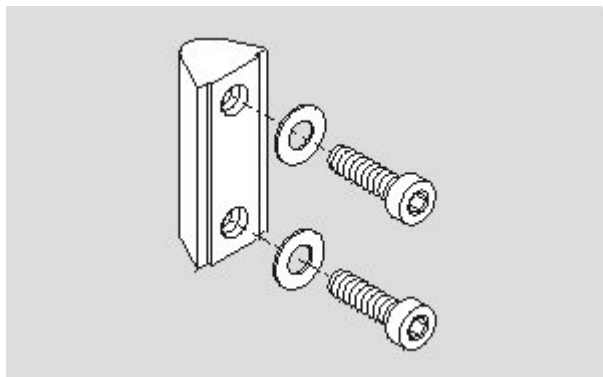

Preferred typ



(Minor differences between the printed image and the original product may exist!)

### Ordering details

Product type description	NST 20-8
Article number	101151388
EAN Code	4030661161235
eCl@ss	27-27-92-91

### Global Properties

Permanent light	Nutzenstein
Weight	25

### Images

K.A. Schmersal GmbH & Co. KG, Mödinghofe 30, D-42279 Wuppertal

The data and values have been checked thoroughly. Technical modifications and errors excepted.

Generiert am 13.02.2019 - 14:15:28h Kasbase 3.3.0.F.64I