

Datasheet - TV7H 256 STL-AS-2138 2S



AS interface safety at work / Safety switchgear / Safety switches / 256 AS 2S / AS - 256 2S
Roller lever 7H-2138



(Minor differences between the printed image and the original product may exist!)

- with integrated AS-i Safety electronics and with M12-connector socket to connect a second position switch
- Lever angle adjustable in 10° steps
- AS-Interface M12 connector
- Thermoplastic enclosure
- Wide range of alternative actuators
- Good resistance to oil and petroleum spirit
- 87 mm x 50,5 mm x 31 mm
- Actuator heads can be repositioned by 4 x 90°
- Mounting details to EN 50047
- AS-Interface LED and status display
- Integrated AS-Interface
- Suitable for AS-i Power24

Ordering details

Product type description	TV7H 256 STL-AS-2138 2S
Article number	TV7H 256 STL-AS-2138 2S
EAN Code	
eCl@ss	27-27-26-01

Approval

Approval



Classification

Application: Two position switches, dependent, on one safety guard:

Standards	EN ISO 13849-1, IEC 61508
PL	up e
Control category	up 4
PFH	2 x 10 ⁻⁸ /
- notice	up to max. 100000 switching cycles/year
SIL	up 3
Mission time	20 Years

Application: Each time one position switch, independent, on two safety guards:

Standards	EN ISO 13849-1, IEC 61508
PL	up c
Control category	up 1
PFH value	1.14 x 10 ⁻⁶ /
- notice	up to max. 100000 switching cycles/year
SIL	up 1
Mission time	20 Years

Global Properties

Permanent light	AS - 256 2S Rollenschwenkhebel 7H 2138
Standards	EN 50295, EN 60947-5-1, EN ISO 13849-1, IEC 61508
Compliance with the Directives (Y/N) 	Yes
Suitable for safety functions (Y/N)	Yes
Materials	
- Material of the housings	Plastic, glass-fibre reinforced thermoplastic, self-extinguishing
- Lever material	Metal film
- Roller material	Plastic
- Material of the connector	Plastic
- Material of the contacts	Silver
Housing coating	
Housing construction form	Norm construction design
Weight	

Mechanical data

Design of electrical connection	connector plug M12, 4-pole
connector	right
Mechanical life	1.000.000 operations
Switching frequency	5000
Design of actuating element	Roller lever
actuating torque	15
restistance to shock	30 / 11
Resistance to vibration	10 ... 150, Amplitude 0,35 / 5
Positive break torque	18.5
Actuating speed for vertical actuation	
- Max. Actuating speed	1

Ambient conditions

Ambient temperature	
- Min. environmental temperature	-25
- Max. environmental temperature	+60
- Min. Storage and transport temperature	-25
- Max. Storage and transport temperature	+85
Relative humidity	30 ... 95
- non-condensing	
- non-icing	
Protection class	IP67 to IEC/EN 60529
Protection rating	II

Electrical data

Design of control element	Opener (NC)
Switching principle	Creep circuit element
- positive break NC contact 	
Number of auxiliary contacts	0
Number of safety contacts	2
Rated impulse withstand voltage	800
Rated insulation voltage	32
Thermal test current	10 A
Utilisation category	AC-15: 230 V / 4 A, DC-13: 24 V / 1 A
Max. fuse rating	6 A gG D-fuse

Electrical data - AS interface

AS-i Supply voltage	18 ... 31.6 VDC, Protection against polarity reversal
AS-i operating current	≤ 50
AS-i Device insulation	internally short-circuit proof
AS-i Specification	
- version	V 3.0
- Profile	S-0.B.F.F
AS-i Inputs	
- Channel 1	Data bits DI 0/DI 1= dynamic code transmission (Z/T 256 AS)
- Channel 2	Data bits DI 2/DI 3= dynamic code transmission (2. switch)
AS-i Outputs	DO 0 ... DO 3 not used
AS-i Parameter bits	P1 ... P3 not used
- P0	Channel 2 switched, switching condition 2. switch
AS-i input module address	0
- Default on address 0, programmable via the AS-Interface Master or Hand-held programming device	

LED switching conditions display

LED switching conditions display (Y/N)	Yes
AS-i LED switching conditions display	
(1) yellow LED	Channel 1 / AS-i SaW Bit 0,1
(2) green/red LED (AS-i duo LED)	Supply voltage / Communication error / slave address = 0
(3) yellow LED	Channel 2 / AS-i SaW Bit 2,3

ATEX

Explosion protection categories for gases	None
Explosion protected category for dusts	None

Dimensions

Dimensions of the sensor	
- Width of sensor	87
- Height of sensor	145.5
- Length of sensor	31

Pin assignment

AS interface Connector	
1	AS interface +
2	None

3

AS interface –

4

None

connector socket 2. switch

Switch travel diagram

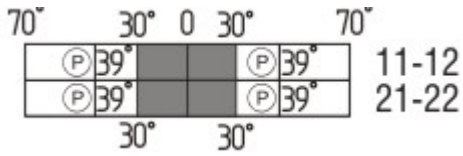

Notes Switch travel diagram

■ Contact closed

□ Contact open

▨ Setting range

Ⓛ Break point

Ⓟ Positive opening sequence/- angle

VS adjustable range of NO contact

VÖ adjustable range of NC contact

N after travel

Ordering suffix

The applicable ordering suffix is added at the end of the part number of the safety switch.

Order example: TV7H 256 STL-AS-2138 2S-FKL

...-FKL Connection for flat cable, left

...-Z Actuator head gasket

Ordering code

(1)(2) 256 (3)-AS 2S

(1)

Z Snap action

T Slow action

(2)

S Plunger S

R Roller plunger R

1R Offset roller lever 1R

K Angle roller lever K

3K Angle roller lever 3K

4K Angle roller lever 4K

K4 Angle roller lever K4

1H Roller lever 1H

12H Roller lever 12H

14H Roller lever 14H

7H Roller lever 7H

(3)

STL connector plug M12, left

FKL Flat plug-in connector, left

Documents

Operating instructions and Declaration of conformity (da) 331 kB, 30.01.2018

Code: mrl_zt-256-as-2s_da

Operating instructions and Declaration of conformity (cs) 345 kB, 30.01.2018

Code: mrl_zt-256-as-2s_cs

Operating instructions and Declaration of conformity (es) 331 kB, 26.01.2018

Code: mrl_zt-256-as-2s_es

Operating instructions and Declaration of conformity (it) 328 kB, 30.01.2018

Code: mrl_zt-256-as-2s_it

Operating instructions and Declaration of conformity (pt) 332 kB, 26.01.2018

Code: mrl_zt-256-as-2s_pt

Operating instructions and Declaration of conformity (nl) 331 kB, 30.01.2018

Code: mrl_zt-256-as-2s_nl

Operating instructions and Declaration of conformity (en) 328 kB, 22.11.2017

Code: mrl_zt-256-as-2s_en

Operating instructions and Declaration of conformity (pl) 345 kB, 30.01.2018

Code: mrl_zt-256-as-2s_pl

Operating instructions and Declaration of conformity (jp) 385 kB, 13.08.2012

Code: mrl_zt-256-as-2s_jp

Operating instructions and Declaration of conformity (fr) 334 kB, 30.01.2018

Code: mrl_zt-256-as-2s_fr

Operating instructions and Declaration of conformity (de) 303 kB, 22.11.2017

Code: mrl_zt-256-as-2s_de

Images



Product photo

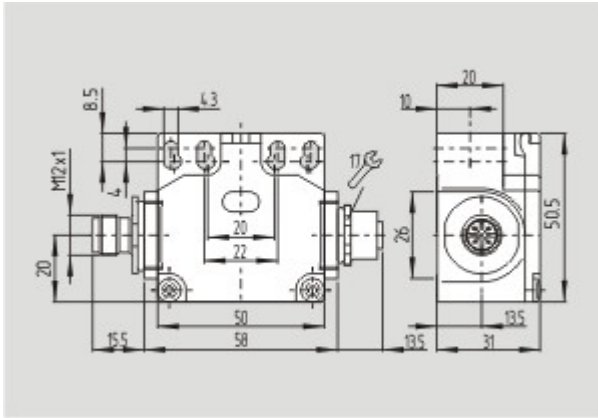

Dimensional drawing (basic component)

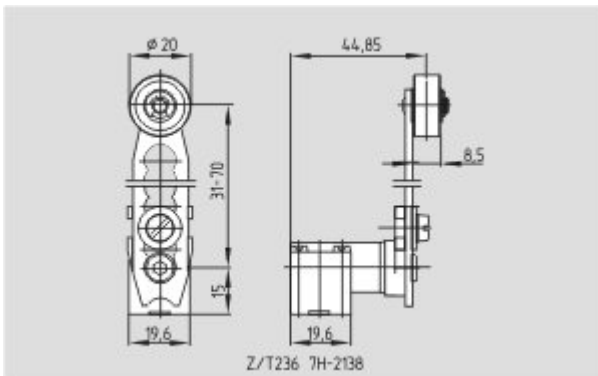

Dimensional drawing (actuator)

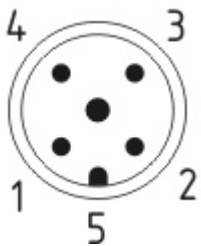

Contact arrangement

K.A. Schmersal GmbH & Co. KG, Mödinghofe 30, D-42279 Wuppertal

The data and values have been checked thoroughly. Technical modifications and errors excepted.

Generiert am 13.02.2019 - 12:43:09h Kasbase 3.3.0.F.64I