

Datasheet - AZM 200CC-T-1P2PA

Solenoid interlock / AZM 200



Preferred typ



(Minor differences between the printed image and the original product may exist!)

- **NOTICE: Available until 2020.12.31 (substitute: AZM201)**
- Thermoplastic enclosure
- Guard locking monitored
- Electronic contact-free, coded system
- Max. length of the sensor chain 200 m
- Self-monitoring series-wiring of 31 sensors
- 3 LEDs to show operating conditions
- Sensor technology permits an offset between actuator and interlock of ± 5 mm vertically and ± 3 mm horizontally
- Intelligent diagnosis
- Manual release

Ordering details

Product type description	AZM 200CC-T-1P2PA
Article number	101180289
EAN Code	4030661313641
eCl@ss	27-27-26-03

Approval

Approval



Classification

Interlocking function:

Standards	EN ISO 13849-1, IEC 61508, IEC 60947-5-3
PL	bis e
Control category	bis 4
PFH	$4.0 \times 10^{-9}/h$
PFD value	1.0×10^{-4}
SIL	bis 3
Mission time	20 Years

Classification	PDF-M
Guard locking function:	
Standards	EN ISO 13849-1, IEC 61508, IEC 60947-5-3
PL	up d
Control category	up 2
PFH value	2.5 x 10 ⁻⁹ /h
PFD value	2.2 x 10 ⁻⁴
SIL	up 2
Mission time	20 Years

Global Properties

Permanent light	AZM 200
Standards	EN 60947-5-1, IEC 61508, EN ISO 13849-1, EN ISO 13849-1
Compliance with the Directives (Y/N) 	Yes
Suitable for safety functions (Y/N)	Yes
Series-wiring	up to 31 components
Length of the sensor chain	max. 200 m
Active principle	inductive
Duty cycle ED	100 %
Materials	
- Material of the housings	Plastic, glass-fibre reinforced thermoplastic
Housing coating	None
Weight	537
Guard locking monitored (Y/N)	Yes
Actuator monitored (Y/N)	No
Idle assignable pushbutton and LED (Y/N)	No
Reaction time	≤ 60
Duration of risk	> 120
Time to readiness	4000
Recommended actuator	AZ/AZM 200-B1

Mechanical data

Design of electrical connection	Spring pulley connection
Cable section	
- Min. Cable section	0,25
- Max. Cable section	1.5
AWG-Number	23 - 15
Mechanical life	≥ 1.000.000 operations
notice	All indications about the cable section are including the conductor ferrules.
restistance to shock	30 g / 11 ms
Resistance to vibration	10 ... 55 HZ, Amplitude 1 mm
Emergency unlocking device (Y/N)	No
Manual release (Y/N)	Yes
Emergency release (Y/N)	No
Latching force	30
Clamping force F	2000 N
Max. Actuating speed	≤ 0,2

Ambient conditions

Ambient temperature	
- Min. environmental temperature	-25

- Max. environmental temperature	+50
Storage and transport temperature	
- Min. Storage and transport temperature	-25
- Max. Storage and transport temperature	+85
Relative humidity	30... 95
- non-condensing	
Protection class	IP67 to IEC/EN 60529
Protection rating	II
Air clearances and creepage distances To IEC/EN 60664-1	
- Rated impulse withstand voltage U_{imp}	0,8 kV
- Overvoltage category	III
- Degree of pollution	3

Electrical data

Number of auxiliary contacts	0
Number of safety contacts	2
Cross circuit/short circuit recognition possible (Y/N)	Yes
Power to unlock	No
Power to lock	Yes
Supply voltage U_B	
- Min. supply voltage	20.4 V DC
- Max. supply voltage	26.4 V DC
Switch frequency	1
Rated insulation voltage U_i	32 V DC
Operating current I_e	1.2 A
Utilisation category	DC-12, DC-13
No-load current I_0	0,6 A
Device insulation	≤ 4 A if used in accordance with UL 508

Electrical data - Safety inputs

Safety inputs	X1 and X2
Rated operating voltage U_e	- 3 V ... 5 V (Low) 15 V ... 30 V (High)
Operating current I_e	> 2 mA / 24 V

Electrical data - Safety outputs

Safety outputs	Y1 and Y2
Fuse rating	short-circuit proof, p-type
Rated operating voltage	0 V ... 4 V under Supply voltage U_B
Residual current I_r	≤ 0,5 mA
Operating current I_e	0,25 A
Utilisation category	DC-12, DC-13

Electrical data - Diagnostic output

Serial diagnostics (Y/N)	No
Fuse rating	p-type, short-circuit proof
Operating current I_e	0,05 A
Utilisation category	DC-12, DC-13
Wiring capacitance for serial diagnostics	-
diagnostic signals	guard door closed

Operating principle of the diagnostic output

notice

The short-circuit proof diagnostic output OUT can be used for central visualisation or control tasks, e.g. in a PLC.

The diagnostic output is not a safety-relevant output!

Electrical data - Solenoid control IN

Rated operating voltage U_e

- 3 V ... 5 V (Low)
15 V ... 30 V (High)

Operating current I_e

typically 10 mA / 24 V, dynamically 20 mA

LED switching conditions display

LED switching conditions display (Y/N)

Yes

LED switching conditions display

- Supply voltage U_B

green LED

- switching condition

yellow LED

- Error functional defect

red LED

ATEX

Explosion protection categories for gases

None

Explosion protected category for dusts

None

Dimensions

Dimensions of the sensor

- Width of sensor

40

- Height of sensor

220

- Length of sensor

50

notice

As long as the actuating unit remains inserted in the solenoid interlock, the unlocked safety guard can be relocked. The safety outputs then will be enabled again; opening the safety guard therefore is not required.

Included in delivery

Included in delivery

AZM 200
Triangular key

Actuators must be ordered separately.

Indication legend

see drawing: Wiring example

With the represented power-to-unlock principle, the solenoid is energised to enable the opening.

With the alternative power-to-lock principle (not represented), the solenoid must be energised to keep the device in closed condition.

Ordering code

AZM 200(1)(2)-T-(3)(4)

(1)

without

B Guard locking monitored

Actuator monitored

(2)

SK	Screw connection
CC	Spring pulley connection
ST1	connector M23 x 1, (8+1-pole)
ST2	connector M12 x 1, 8-pole
(3)	
1P2P	1 Diagnostic output and 2 Safety outputs, p-type
1P2PW	gleich - 1P2P, combined diagnostic signal: guard door closed and interlocking device locked
SD2P	serial diagnostic output and 2 Safety outputs, p-type
(4)	
<i>without</i>	Power to unlock
A	Power to lock

Documents

Operating instructions and Declaration of conformity (pl) 372 kB, 07.06.2017

Code: mrl_azm200t_pl

Operating instructions and Declaration of conformity (jp) 450 kB, 09.10.2017

Code: mrl_azm200t_jp

Operating instructions and Declaration of conformity (es) 349 kB, 31.05.2017

Code: mrl_azm200t_es

Operating instructions and Declaration of conformity (cn) 507 kB, 23.11.2018

Code: mrl_azm200t_cn

Operating instructions and Declaration of conformity (en) 348 kB, 26.09.2017

Code: mrl_azm200t_en

Operating instructions and Declaration of conformity (pt) 355 kB, 26.05.2017

Code: mrl_azm200t_pt

Operating instructions and Declaration of conformity (fr) 353 kB, 03.07.2017

Code: mrl_azm200t_fr

Operating instructions and Declaration of conformity (it) 349 kB, 28.06.2017

Code: mrl_azm200t_it

Operating instructions and Declaration of conformity (de) 336 kB, 26.09.2017

Code: mrl_azm200t_de

Operating instructions and Declaration of conformity (nl) 398 kB, 03.08.2018

Code: mrl_azm200t_nl

Operating instructions and Declaration of conformity (da) 312 kB, 22.08.2013

Code: mrl_azm200t_da

Operating instructions and Declaration of conformity (sv) 343 kB, 07.08.2015

Code: mrl_azm200t_sv

Wiring example (99) 21 kB, 12.01.2009

Code: kazm2l26

Diagnosis tables (en) 136 kB, 12.01.2009

Code: b_tabp02

Diagnosis tables (de) 135 kB, 12.01.2009

Code: b_tabp01

Brochure (de) 6 MB, 15.02.2018

Code: b_css_brosch09_de

Brochure (en) 6 MB, 15.02.2018

Code: b_css_brosch09_en

TÜV certification (de, en) 848 kB, 09.08.2017

Code: z_azmp04

EAC certification (ru) 809 kB, 05.10.2015

Code: q_6040p17_ru

Images

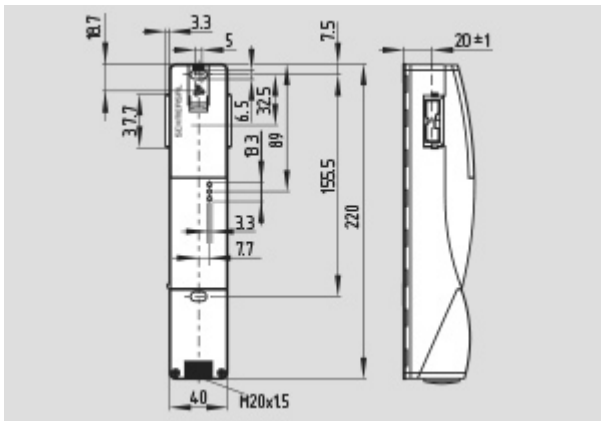

Dimensional drawing (miscellaneous)

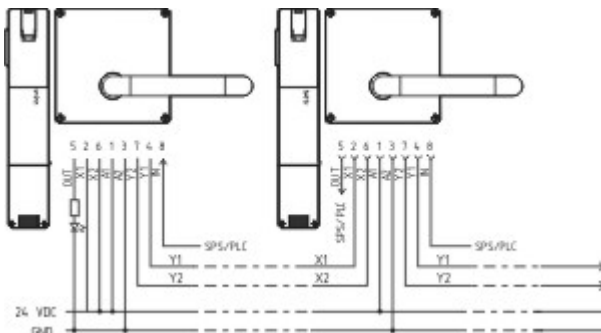

Wiring example

System components

Actuator



101183465 - AZ/AZM 200-B1-LT

- Actuators with return spring
- Actuator for sliding guards
- Tolerates up to max. 5 mm overtravel



101183466 - AZ/AZM 200-B1-LTP0

- Actuators with return spring
- Actuator for sliding guards
- Tolerates up to max. 5 mm overtravel



101183469 - AZ/AZM 200-B1-RT

- Actuators with return spring
- Actuator for sliding guards
- Tolerates up to max. 5 mm overtravel



101183470 - AZ/AZM 200-B1-RTP0

- Actuators with return spring
- Actuator for sliding guards
- Tolerates up to max. 5 mm overtravel



101178681 - AZ/AZM 200-B30-LTAG1

- Actuator for hinged guards
 - With door detection sensor T
 - Easy and intuitive operation
 - No risk of injury from protruding actuator
 - No supplementary door handles required
 - Does not protrude into the door opening
 - Various handles available
- Greater mechanical stability



101178668 - AZ/AZM 200-B30-LTAG1P1

- One-hand emergency exit, even in de-energised condition
 - Actuator for hinged guards
 - With door detection sensor T
 - Easy and intuitive operation
 - No risk of injury from protruding actuator
 - No supplementary door handles required
 - Does not protrude into the door opening
 - Various handles available
- Greater mechanical stability



101186150 - AZ/AZM 200-B30-LTAG1P20

- One-hand emergency exit, even in de-energised condition
 - Actuator for hinged guards
 - With door detection sensor T
 - Easy and intuitive operation
 - No risk of injury from protruding actuator
 - No supplementary door handles required
 - Does not protrude into the door opening
 - Various handles available
- Greater mechanical stability

101192102 - AZ/AZM 200-B30-LTAG1P25

- One-hand emergency exit,



- even in de-energised condition
 - Actuator for hinged guards
 - With door detection sensor T
 - Easy and intuitive operation
 - No risk of injury from protruding actuator
 - No supplementary door handles required
 - Does not protrude into the door opening
 - Various handles available
- Greater mechanical stability



101181137 - AZ/AZM 200-B30-LTAG2

- Actuator for hinged guards
 - With door detection sensor T
 - Easy and intuitive operation
 - No risk of injury from protruding actuator
 - No supplementary door handles required
 - Does not protrude into the door opening
 - Various handles available
- Greater mechanical stability



101181141 - AZ/AZM 200-B30-LTAG2P1

- One-hand emergency exit, even in de-energised condition
 - Actuator for hinged guards
 - With door detection sensor T
 - Easy and intuitive operation
 - No risk of injury from protruding actuator
 - No supplementary door handles required
 - Does not protrude into the door opening
 - Various handles available
- Greater mechanical stability



101189020 - AZ/AZM 200-B30-LTAG2P20

- One-hand emergency exit, even in de-energised condition
 - Actuator for hinged guards
 - With door detection sensor T
 - Easy and intuitive operation
 - No risk of injury from protruding actuator
 - No supplementary door handles required
 - Does not protrude into the door opening
 - Various handles available
- Greater mechanical stability



101192106 - AZ/AZM 200-B30-LTAG2P25

- One-hand emergency exit, even in de-energised condition
 - Actuator for hinged guards
 - With door detection sensor T
 - Easy and intuitive operation
 - No risk of injury from protruding actuator
 - No supplementary door handles required
 - Does not protrude into the door opening
 - Various handles available
- Greater mechanical stability

101178680 - AZ/AZM 200-B30-RTAG1

- Actuator for hinged guards
- With door detection sensor T
- Easy and intuitive operation



- No risk of injury from protruding actuator
 - No supplementary door handles required
 - Does not protrude into the door opening
 - Various handles available
- Greater mechanical stability



101178738 - AZ/AZM 200-B30-RTAG1P1

- One-hand emergency exit, even in de-energised condition
 - Actuator for hinged guards
 - With door detection sensor T
 - Easy and intuitive operation
 - No risk of injury from protruding actuator
 - No supplementary door handles required
 - Does not protrude into the door opening
 - Various handles available
- Greater mechanical stability



101186144 - AZ/AZM 200-B30-RTAG1P20

- One-hand emergency exit, even in de-energised condition
 - Actuator for hinged guards
 - With door detection sensor T
 - Easy and intuitive operation
 - No risk of injury from protruding actuator
 - No supplementary door handles required
 - Does not protrude into the door opening
 - Various handles available
- Greater mechanical stability



101192103 - AZ/AZM 200-B30-RTAG1P25

- One-hand emergency exit, even in de-energised condition
 - Actuator for hinged guards
 - With door detection sensor T
 - Easy and intuitive operation
 - No risk of injury from protruding actuator
 - No supplementary door handles required
 - Does not protrude into the door opening
 - Various handles available
- Greater mechanical stability



101181139 - AZ/AZM 200-B30-RTAG2

- Actuator for hinged guards
 - With door detection sensor T
 - Easy and intuitive operation
 - No risk of injury from protruding actuator
 - No supplementary door handles required
 - Does not protrude into the door opening
 - Various handles available
- Greater mechanical stability

101181143 - AZ/AZM 200-B30-RTAG2P1

- One-hand emergency exit, even in de-energised condition
- Actuator for hinged guards
- With door detection sensor T
- Easy and intuitive operation



- No risk of injury from protruding actuator
 - No supplementary door handles required
 - Does not protrude into the door opening
 - Various handles available
- Greater mechanical stability

101191659 - AZ/AZM 200-B30-RTAG2P20



- One-hand emergency exit, even in de-energised condition
 - Actuator for hinged guards
 - With door detection sensor T
 - Easy and intuitive operation
 - No risk of injury from protruding actuator
 - No supplementary door handles required
 - Does not protrude into the door opening
 - Various handles available
- Greater mechanical stability

101192104 - AZ/AZM 200-B30-RTAG2P25



- One-hand emergency exit, even in de-energised condition
 - Actuator for hinged guards
 - With door detection sensor T
 - Easy and intuitive operation
 - No risk of injury from protruding actuator
 - No supplementary door handles required
 - Does not protrude into the door opening
 - Various handles available
- Greater mechanical stability