

Datasheet - IFL 15-300L-10/01P

Inductive proximity switch / Housing construction form: cylinder, thread / IFL - M30



Preferred typ



- Design M30
- 1 Cable entry M 16 x 1.5
- Thermoplastic enclosure
- DC 3-wire
- Long design
- Double-insulated

(Minor differences between the printed image and the original product may exist!)

Ordering details

Product type description	IFL 15-300L-10/01P
Article number	101126971
EAN Code	4030661278032
eCl@ss	27-27-01-01

Approval

Approval



CCC

Global Properties

Permanent light	IFL - M30
Standards	IEC/EN 60947-5-2; DIN VDE 0660-208
Compliance with the Directives (Y/N)	Yes
Operating resource protection class	Protection class 2
Materials	
- Material of the housings	Plastic
- Material of the nuts	Plastic
- Material of the washer	perbunan®
- Material of the active surface	Plastic
Housing coating	None
Housing construction form	cylinder, thread
Weight	70

Mechanical data

Design of electrical connection	Screw connection
Conductor with strain relief	No
Cable section	
- Min. Cable section	
- Max. Cable section	1 x 1.5
mechanical installation conditions	not flush
Switch distance S_n	15 mm
Reduction factor 1 met (Y/N)	No
Protection circuit	inductive interference protection, Protection against polarity reversal
Pressure resistant (Y/N)	No
Tightening torque for nuts	A/F 36 max. 400 Ncm
• Wiring compartment	

Ambient conditions

Ambient temperature	
- Min. environmental temperature	-25
- Max. environmental temperature	+70
Protection class	IP65 to IEC/EN 60529

Electrical data

Design of control element	Normally open contact (NO) or Opener (NC)
Number of wire	3
Voltage type	DC, direct current
Supply voltage U_B	
- Min. supply voltage	10
- Max. supply voltage	60
Switch frequency	approx. 100 HZ
Voltage drop U_d	approx. 1.5 V (400 mA)
Operating current I_e	400 mA
No-load current I_o	approx. 5.5 mA (24 V)

Outputs

Design of control output	PNP
--------------------------	-----

LED switching conditions display

LED switching conditions display (Y/N)	Yes
- yellow LED	

ATEX

Explosion protection categories for gases	None
Explosion protected category for dusts	None

Dimensions

Dimensions of the sensor

- Length of sensor	118
- Diameter of sensor	M30

notice

Instead of nuts, a mounting clamp can be provided.
 Programmable by repositioning the plug-in jumper at the terminal screws

Diagram

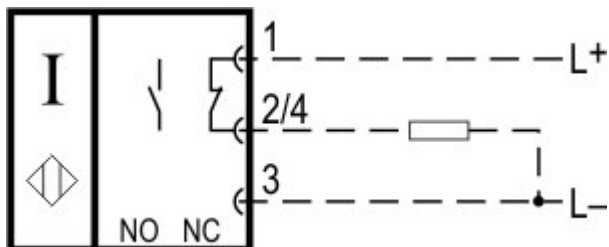

Note Diagram

- positive break NC contact
- active
- no active
- Normally-open contact
- Normally-closed contact

Ordering suffix

The applicable ordering suffix is added at the end of the part number of the safety switch.

Order example: IFL 15-300L-10/01P-**1665-1**

...-**1665-1**

short-circuit and overload proof
 Operating current I_e : 300 mA
 Voltage drop U_d : approx. 1 V (300 mA)

Ordering code

IFL (1)-(2)(3)-(4)(5)(6)(7)-(8)

(1)	
10	Switch distance 10 mm
15	Switch distance 15 mm
(2)	
30	cylinder, thread M30, Metal film
300	cylinder, thread M30, Plastic
(3)	
<i>without</i>	Included in standard version Design
M	miniature body
L	Long design
(4)	
01	Opener (NC)
10	Normally open contact (NO)
10/01	Normally open contact (NO) / Opener (NC) with Wiring compartment
11	Normally open contact (NO) / Opener (NC) antivalent

(5)		
<i>without</i>		Cable
ST		Connector
T		Conductor with strain relief
D		DC 2-wire
(6)		
<i>without</i>		Included in standard version Plug-in connection
2		Alternative Plug-in connection
(7)		
N		n-type
P		p-type
(8)		
1310		Max. +110°C (<i>Only for Alternating current AC</i>)
2130		Max. +130°C, without LED switching conditions display
1766		Max. +110°C (<i>Only for p-type or n-type</i>)

Documents

Operating instructions (nl) 134 kB, 01.08.2018

Code: mrl_ifl-allgemein_nl

Operating instructions (en) 128 kB, 31.08.2016

Code: mrl_ifl-allgemein_en

Operating instructions (pl) 137 kB, 21.10.2016

Code: mrl_ifl-allgemein_pl

Operating instructions (pt) 109 kB, 06.04.2017

Code: mrl_ifl-allgemein_pt

Operating instructions (it) 108 kB, 21.10.2016

Code: mrl_ifl-allgemein_it

Operating instructions (es) 110 kB, 21.10.2016

Code: mrl_ifl-allgemein_es

Operating instructions (cn) 177 kB, 05.05.2017

Code: mrl_ifl-allgemein_cn

Operating instructions (de) 131 kB, 31.08.2016

Code: mrl_ifl-allgemein_de

Operating instructions (fr) 110 kB, 21.10.2016

Code: mrl_ifl-allgemein_fr

Declaration of conformity (en) 91 kB, 13.04.2017

Code: konfi_ifl_en

Declaration of conformity (de) 96 kB, 01.07.2016

Code: konfi_ifl_de

CCC certification (cn) 3 MB, 11.07.2018

Code: q_iflp03

Images

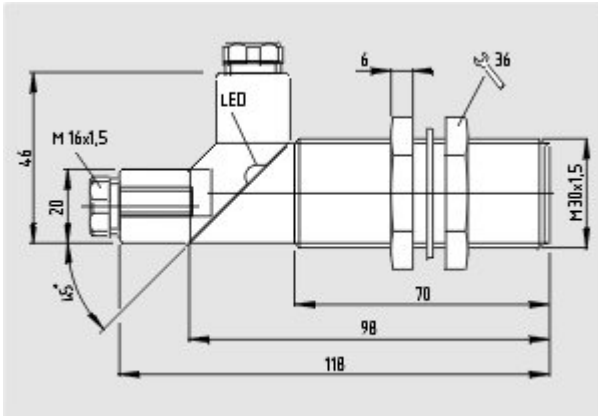

Dimensional drawing (basic component)

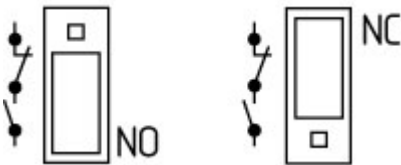

Operating principle

System components

Mounting accessories



101068520 - MOUNTING CLAMP H 30

- For a smooth fitting of the proximity switches with cylindric shape Ø 30 mm or thread M30