

## Datasheet - \$missingName\$

Solenoid interlock / AZM201



(Minor differences between the printed image and the original product may exist!)

- Thermoplastic enclosure
- RFID-technology for needs-based protection against tampering
- Max. length of the sensor chain 200 m
- Self-monitoring series-wiring of 31 sensors
- 3 LEDs to show operating conditions
- Sensor technology permits an offset between actuator and interlock of  $\pm 5$  mm vertically and  $\pm 3$  mm horizontally
- Suitable for hinged and sliding guards
- Intelligent diagnosis
- Manual release
- Repeated individual coding with RFID technology
- Coding level "High" according to ISO 14119
- Power to unlock
- Guard locking monitored

### Ordering details

Product type description	AZM201Z-I2-ST2-T-SD2P
Article number	103013492
EAN Code	4030661493350
eCl@ss	27-27-26-03

### Approval

Approval



### Classification

#### Interlocking function:

Standards	EN ISO 13849-1, IEC 61508, IEC 62061
PL	e
Control category	4
PFH value	$1.9 \times 10^{-9}$ / h
PFD value	$1.6 \times 10^{-4}$
SIL	Suitable for SIL 3 applications
Mission time	20 Years

### Guard locking function:

Standards	-
PL	-
Control category	-
PFH value	-
PFD value	-
SIL	-
Mission time	-

### Global Properties

---

Permanent light	AZM201
Standards	IEC 60947-5-1, IEC 60947-5-3, ISO 14119, ISO 13849-1, IEC 61508, IEC 62061
Compliance with the Directives (Y/N) 	Yes
Suitable for safety functions (Y/N)	Yes
Protection rating	III
Series-wiring	up to 31 components
Length of the sensor chain	200 m
Active principle	RFID
Duty cycle	100
Coding levels according to ISO 14119	High
Coding	Individual coding, multiple teaching
Materials	
- Material of the housings	Plastic, glass-fibre reinforced thermoplastic
Housing coating	None
Weight	590
Guard locking monitored (Y/N)	Yes
Actuator monitored (Y/N)	No
Idle assignable pushbutton and LED (Y/N)	No
Response time	
Actuator	≤ 100
Duration of risk	< 200
Time to readiness	< 4000
Recommended actuator	AZ/AZM201-B1, AZ/AZM201-B30
- Actuator	≤ 100 ms
- Inputs	≤ 0,5 ms

### Mechanical data

---

Design of electrical connection	Connector M12, 8-pole
Cable section	
- Min. Cable section	-
- Max. Cable section	-
AWG-Number	-
Mechanical life	≥ 1.000.000 operations
notice	-
restistance to shock	30 / 11
Resistance to vibration	10 ... 150 HZ, Amplitude 0,35 mm
Emergency unlocking device (Y/N)	No
Manual release (Y/N)	Yes
Emergency release (Y/N)	No
Latching force	30
Clamping force	2000
Max. Actuating speed	≤ 0,2

## Ambient conditions

---

Ambient temperature	
- Min. environmental temperature	-25
- Max. environmental temperature	+60
Storage and transport temperature	
- Min. Storage and transport temperature	-25
- Max. Storage and transport temperature	+85
Relative humidity	30... 95
- non-condensing	
Protection class	IP66, IP67 to IEC 60529
Air clearances and creepage distances To IEC/EN 60664-1	
- Rated impulse withstand voltage	0,8
- Overvoltage category	III
- Degree of pollution	3

## Electrical data

---

Number of auxiliary contacts	0
Number of safety contacts	2
Cross circuit/short circuit recognition possible (Y/N)	Yes
Power to unlock	Yes
Power to lock	No
Supply voltage	
- Min. supply voltage	20.4 V DC
- Max. supply voltage	26.4 V DC
Switch frequency	1
Rated insulation voltage	32 V DC
Operating current	1.2 A
Utilisation category	DC-13
No-load current	0,6 A
Device insulation	≤ 2 A

## Electrical data - Safety inputs

---

Safety inputs	X1 and X2
Rated operating voltage	-3 ... 5 (Low) 15 ... 30 (High)
Operating current	typically 2 at 24

## Electrical data - Safety outputs

---

Safety outputs	Y1 and Y2
Fuse rating	short-circuit proof, p-type
Rated operating voltage	0 ... 4 under
Residual current	≤ 0,5
Operating current	max. each 0,25 A
Utilisation category	DC-13

## Electrical data - Diagnostic output

---

Serial diagnostics (Y/N)	Yes
Fuse rating	-

Operating current $I_e$	-
Utilisation category	-
Wiring capacitance for serial diagnostics diagnostic signals	max. 50 nF to SD-interface
Operating principle of the diagnostic output	The short-circuit proof diagnostic output OUT can be used for central visualisation or control tasks, e.g. in a PLC.
notice	The diagnostic output is not a safety-relevant output!

## Electrical data - Solenoid control IN

---

Rated operating voltage $U_e$	-
Operating current $I_e$	-
Control command	Interlocking the solenoid interlock

## LED switching conditions display

---

LED switching conditions display (Y/N)	Yes
LED switching conditions display	
- Supply voltage	green LED
- switching condition	yellow LED
- Error functional defect	red LED

## ATEX

---

Explosion protection categories for gases	None
Explosion protected category for dusts	None

## Dimensions

---

Dimensions of the sensor	
- Width of sensor	40 mm
- Height of sensor	220
- Length of sensor	50

## Pin assignment

---

1	A1 Supply voltage UB
2	X1 safety input 1
3	A2 GND
4	Y1 safety output 1
5	OUT serial diagnostic output
6	X2 safety input 2
7	Y2 safety output 2
8	IN serial diagnostic input

## notice

---

As long as the actuating unit remains inserted in the solenoid interlock, the unlocked safety guard can be relocked. The safety outputs then will be enabled again; opening the safety guard therefore is not required.

## Included in delivery

---

Included in delivery	AZM201 Triangular key
----------------------	--------------------------

Actuators must be ordered separately.

## Ordering code

---

AZM201(1)-(2)-(3)-T-(4)-(5)

(1)

Z

B

(2)

*without*

Included in standard version Coding

I1

Individual coding

I2

Individual coding,

(3)

SK

Screw terminals

CC

Cage clamps

ST2

connector plug M12, 8-pole

(4)

1P2PW

1 Diagnostic output, p-type and

2 Safety outputs, p-type

(combined diagnostic signal: guard door closed and interlocking device locked)

SD2P

serial diagnostic output and 2 Safety outputs, p-type

(5)

*without*

Power to unlock

A

Power to lock

## Documents

---

**Operating instructions and Declaration of conformity** (pl) 480 kB, 26.11.2018

Code: mrl\_azm201\_pl

**Operating instructions and Declaration of conformity** (nl) 451 kB, 23.10.2018

Code: mrl\_azm201\_nl

**Operating instructions and Declaration of conformity** (de) 391 kB, 10.08.2018

Code: mrl\_azm201\_de

**Operating instructions and Declaration of conformity** (es) 459 kB, 23.08.2018

Code: mrl\_azm201\_es

**Operating instructions and Declaration of conformity** (fr) 423 kB, 03.05.2018

Code: mrl\_azm201\_fr

**Operating instructions and Declaration of conformity** (en) 458 kB, 10.08.2018

Code: mrl\_azm201\_en

**Operating instructions and Declaration of conformity** (it) 417 kB, 19.06.2018

Code: mrl\_azm201\_it

**Operating instructions and Declaration of conformity** (jp) 528 kB, 12.10.2017

Code: mrl\_azm201\_jp

**Operating instructions and Declaration of conformity** (pt) 461 kB, 15.08.2018

Code: mrl\_azm201\_pt

**Operating instructions and Declaration of conformity** (cn) 624 kB, 23.11.2018

Code: mrl\_azm201\_cn

**Wiring example** (99) 21 kB, 12.01.2009

Code: kazm2I26

**Brochure** (de) 6 MB, 15.02.2018

Code: b\_css\_brosch09\_de

**Brochure** (en) 6 MB, 15.02.2018

Code: b\_css\_brosch09\_en

**TÜV certification** (de, en) 352 kB, 06.02.2018

Code: z\_azmp07

## Images

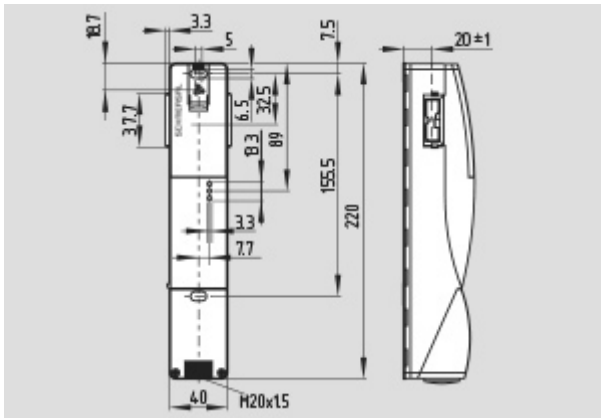

Dimensional drawing (miscellaneous)

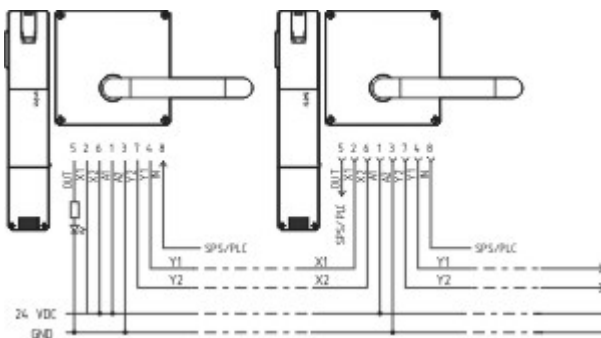

Wiring example

## System components

### Actuator



### 103013499 - AZ/AZM201-B30-RTAG1P1-SZ

- Actuator for hinged guards
- Easy and intuitive operation
- No risk of injury from protruding actuator
- No supplementary door handles required
- Does not protrude into the door opening
- for right hinged doors
- with handle and Emergency exit handle

- with integrated lockout tag



**103013497 - AZ/AZM201-B30-RTAG1P1**

- Actuator for hinged guards
- Easy and intuitive operation
- No risk of injury from protruding actuator
- No supplementary door handles required
- Does not protrude into the door opening
- for right hinged doors
- with handle and Emergency exit handle



**103013502 - AZ/AZM201-B30-RTAG1**

- Actuator for hinged guards
- Easy and intuitive operation
- No risk of injury from protruding actuator
- No supplementary door handles required
- Does not protrude into the door opening
- for right hinged doors
- with handle



**103013500 - AZ/AZM201-B30-LTAG1P1-SZ**

- Actuator for hinged guards
- Easy and intuitive operation
- No risk of injury from protruding actuator
- No supplementary door handles required
- Does not protrude into the door opening
- for left hinged doors
- with handle and Emergency exit handle
- with integrated lockout tag



**103013498 - AZ/AZM201-B30-LTAG1P1**

- Actuator for hinged guards
- Easy and intuitive operation
- No risk of injury from protruding actuator
- No supplementary door handles required
- Does not protrude into the door opening
- for left hinged doors
- with handle and Emergency exit handle



**103013501 - AZ/AZM201-B30-LTAG1**

- Actuator for hinged guards
- Easy and intuitive operation
- No risk of injury from protruding actuator
- No supplementary door handles required
- Does not protrude into the door opening
- for left hinged doors
- with handle



**103013495 - AZ/AZM201-B1-RTP0**

- Actuators with return spring
- Actuator for sliding guards
- Tolerates up to max. 5 mm overtravel
- for right hinged doors
- with Emergency exit

**103013494 - AZ/AZM201-B1-RT**

- Actuators with return spring
- Actuator for sliding guards



- Tolerates up to max. 5 mm overtravel
- for right hinged doors



**103013496 - AZ/AZM201-B1-LTP0**

- Actuators with return spring
- Actuator for sliding guards
- Tolerates up to max. 5 mm overtravel
- for left hinged doors
- with Emergency exit



**103013493 - AZ/AZM201-B1-LT**

- Actuators with return spring
- Actuator for sliding guards
- Tolerates up to max. 5 mm overtravel
- for left hinged doors

K.A. Schmersal GmbH & Co. KG, Möddinghofe 30, D-42279 Wuppertal

The data and values have been checked thoroughly. Technical modifications and errors excepted.

Generiert am 13.02.2019 - 14:49:50h Kasbase 3.3.0.F.64I