

Datasheet - TV10S 500L-22Z

Safety switch for hinged guards / Hinge safety switch / T.V10S 500



Preferred typ



- Metal enclosure
- Good resistance to oil and petroleum spirit
- Actuator shaft can be turned 360°
- 110 mm x 110 mm x 84 mm
- 3-channel, alternating monitoring
- 2 Cable entry M 20 x 1.5
- Universal joint to compensate axial displacement

(Minor differences between the printed image and the original product may exist!)

Ordering details

Product type description	TV10S 500L-22Z
Article number	101170114
EAN Code	4030661297248
eCl@ss	27-27-26-01

Approval

Approval



CCC

Classification

Standards	EN ISO 13849-1
B10d Normally-closed contact (NC)	20.000.000
Mission time	20 Years
notice	$MTTF_d = \frac{B_{10d}}{0,1 \times n_{op}}$ $n_{op} = \frac{d_{ap} \times h_{op} \times 3600 \text{ s/h}}{t_{cycle}}$

Global Properties

Permanent light

T.V10S 500

Standards	EN 60947-5-1, BG-GS-ET-15
Materials	
- Material of the housings	Aluminium
- Material of the contacts	Silver
Housing coating	painted
Weight	720

Mechanical data

Design of electrical connection	Screw connection
Cable entry M 20 x 1.5	2
Cable section	
- Min. Cable section	
- Max. Cable section	1 x 1.5 mm ²
Design of actuating element	Other
Mechanical life	3.000.000 operations
Switching frequency	max. 1000 /h
notice	All indications about the cable section are including the conductor ferrules.
Shaft bore	Ø 10
Positive break angle	14 °
Positive break torque	15 Ncm
socket (Y/N)	No
Universal joint (Y/N)	Yes

Ambient conditions

Ambient temperature	
- Min. environmental temperature	-25 °C
- Max. environmental temperature	+80 °C
Protection class	IP67

Electrical data

Design of control element	Normally open contact (NO), Opener (NC)
Switching principle	Creep circuit element
Number of auxiliary contacts	3
Number of safety contacts	1
Rated impulse withstand voltage U _{imp}	4 kV
Rated insulation voltage U _i	250 V
Thermal test current I _{the}	6 A
Utilisation category	AC-15: 230 V / 4 A, DC-13: 24 V / 1 A
Max. fuse rating	6 A gG D-fuse

ATEX

Explosion protection categories for gases	None
Explosion protected category for dusts	None

Dimensions

Dimensions of the sensor	
- Width of sensor	110 mm

- Height of sensor
- Length of sensor

110 mm
84 mm

Diagram

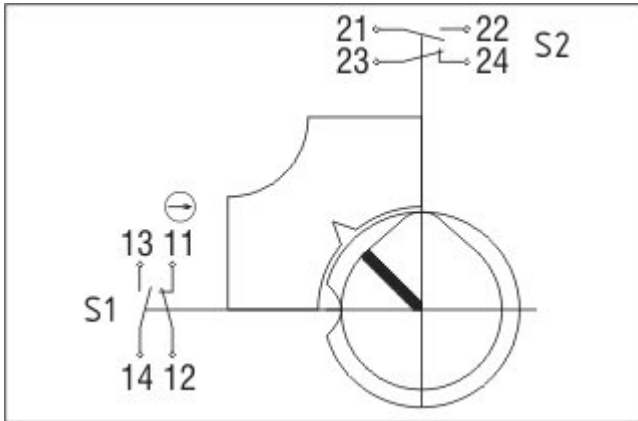

Note Diagram

- positive break NC contact
- active
- no active
- Normally-open contact
- Normally-closed contact

Ordering code

T(1)V10S 500L-(2)Z

(1)

without

1

(2)

22

33

with universal joint

with socket

2 Normally open contact (NO) / 2 Opener (NC)

3 Normally open contact (NO) / 3 Opener (NC)

Documents

Operating instructions and Declaration of conformity (da) 243 kB, 18.06.2013

Code: mrl_tv10s500_da

Operating instructions and Declaration of conformity (es) 281 kB, 21.12.2017

Code: mrl_tv10s500_es

Operating instructions and Declaration of conformity (pt) 282 kB, 31.01.2018

Code: mrl_tv10s500_pt

Operating instructions and Declaration of conformity (fr) 285 kB, 28.11.2017

Code: mrl_tv10s500_fr

Operating instructions and Declaration of conformity (nl) 281 kB, 13.08.2018

Code: mrl_tv10s500_nl

Operating instructions and Declaration of conformity (jp) 993 kB, 22.09.2011

Code: mrl_tv10s500_jp

Operating instructions and Declaration of conformity (de) 263 kB, 14.11.2017

Code: mrl_tv10s500_de

Operating instructions and Declaration of conformity (pl) 309 kB, 23.03.2018

Code: mrl_tv10s500_pl

Operating instructions and Declaration of conformity (it) 281 kB, 28.11.2017

Code: mrl_tv10s500_it

Operating instructions and Declaration of conformity (en) 283 kB, 14.11.2017

Code: mrl_tv10s500_en

CCC certification (en) 577 kB, 12.12.2006

Code: q_349p02

CCC certification (cn) 609 kB, 12.12.2006

Code: q_349p03

Images



Product photo

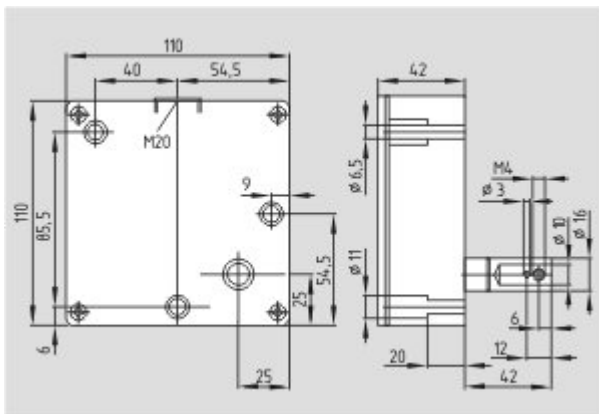

Dimensional drawing (basic component)

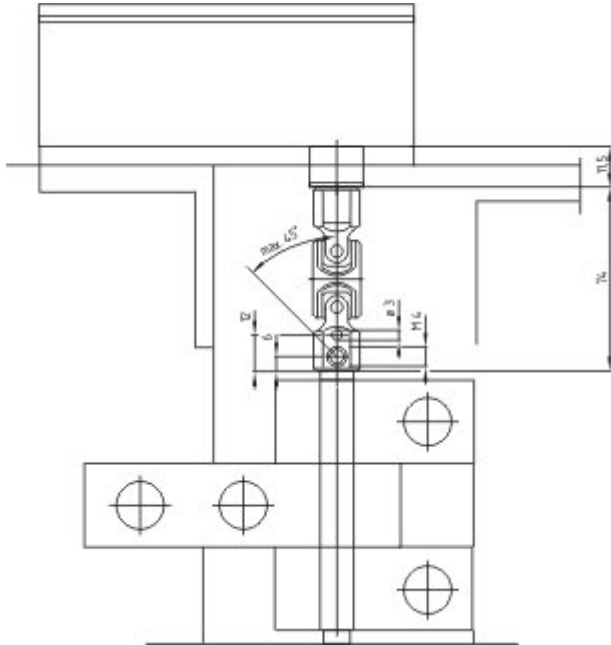

Dimensional drawing (basic component)

K.A. Schmersal GmbH & Co. KG, Mödinghofe 30, D-42279 Wuppertal

The data and values have been checked thoroughly. Technical modifications and errors excepted.

Generiert am 13.02.2019 - 14:32:12h Kasbase 3.3.0.F.64I