

## Datasheet - TK 452-12Y

Position switch / medium heavy Position switch / T 452 / 452 Offset roller lever K



- Metal enclosure
- 118 mm x 127 mm x 64 mm ( basic component)
- Actuator heads can be repositioned by 4 x 90°
- 2 cable entries M 25 x 1.5

(Minor differences between the printed image and the original product may exist!)

### Ordering details

Product type description	TK 452-12Y
Article number	101059019
EAN Code	4030661034522
eCl@ss	27-27-06-01

### Approval

Approval



### Global Properties

Permanent light	452 Rollenhebel K
Standards	EN 60947-5-1
Compliance with the Directives (Y/N) 	Yes
Suitable for safety functions (Y/N)	No
Standard housing (Y/N)	No
Materials	
- Material of the housings	cast iron, galvanized
- Roller material	Plastic
- Material of the contacts	Silver
Housing coating	painted

Weight	1621
Slide form	Castor

## Mechanical data

---

Design of electrical connection	Screw connection
Cable section	
- Min. Cable section	1.5
- Max. Cable section	2.5
AWG-Number	13
Active principle	mechanical
Mechanical life	10.000.000 operations
notice	All indications about the cable section are including the conductor ferrules.
Design of actuating element	Offset roller lever
Bounce duration	
Switchover time	
Contact opening	2 x 6
Actuating speed with vertical actuating angle to switch axis	
- Min. Actuating speed	1
- Max. Actuating speed	0,5
- Actuating angle from left of switch axis	45
- Actuating angle from right of switch axis	30

## Ambient conditions

---

Ambient temperature	
- Min. environmental temperature	-30
- Max. environmental temperature	+90
Protection class	IP65 to IEC/EN 60529

## Electrical data

---

Design of control element	Normally open contact (NO), Opener (NC)
- with double break	
Switching principle	Creep circuit element
- positive break NC contact 	
Number of shutters	1
Number of openers	2
Rated impulse withstand voltage	6
Rated insulation voltage	400
Thermal test current	16 A
Utilisation category	AC-15: 400 V / 4 A
Max. fuse rating	16 A gG D-fuse

## Dimensions

---

Dimensions of the sensor	
- Width of sensor	118
- Height of sensor	201
- Length of sensor	64
Roller wide	6.5
Roller diameter	25

## notice

---

notice

**Actuation from the right should be avoided, since this reduces the mechanical life of the position switch.**

## Ordering suffix

---

*The applicable ordering suffix is added at the end of the part number of the safety switch.*

Order example: TK 452-12Y- **1276-2**

...- <b>1276-2</b>	gold-plated contacts
...- <b>H</b>	Slow action with staggered contacts
...- <b>UE</b>	Slow action with overlapping contacts
...- <b>RMS</b>	Available with metal roller

## Documents

---

**Operating instructions and Declaration of conformity (nl)** 95 kB, 20.07.2018

Code: mrlk\_posi-allgemein\_nl

**Operating instructions and Declaration of conformity (ru)** 133 kB, 09.07.2018

Code: mrlk\_posi-allgemein\_ru

**Operating instructions and Declaration of conformity (es)** 88 kB, 09.07.2018

Code: mrlk\_posi-allgemein\_es

**Operating instructions and Declaration of conformity (en)** 86 kB, 09.07.2018

Code: mrlk\_posi-allgemein\_en

**Operating instructions and Declaration of conformity (cn)** 138 kB, 09.07.2018

Code: mrlk\_posi-allgemein\_cn

**Operating instructions and Declaration of conformity (it)** 86 kB, 09.07.2018

Code: mrlk\_posi-allgemein\_it

**Operating instructions and Declaration of conformity (jp)** 285 kB, 09.07.2018

Code: mrlk\_posi-allgemein\_jp

**Operating instructions and Declaration of conformity (pl)** 118 kB, 09.07.2018

Code: mrlk\_posi-allgemein\_pl

**Operating instructions and Declaration of conformity (fr)** 85 kB, 09.07.2018

Code: mrlk\_posi-allgemein\_fr

**Operating instructions and Declaration of conformity (pt)** 86 kB, 09.07.2018

Code: mrlk\_posi-allgemein\_pt

**Operating instructions and Declaration of conformity (de)** 88 kB, 09.07.2018

Code: mrlk\_posi-allgemein\_de

**Declaration of conformity** (de) 94 kB, 08.08.2016

Code: \_\_422p01

**Declaration of conformity** (pl) 129 kB, 08.08.2016

Code: \_\_422p01\_pl

**Declaration of conformity** (en) 84 kB, 29.11.2018

Code: \_\_422p01\_en

**CCC certification** (cn) 3 MB, 09.04.2018

Code: q\_352p03

**CCC certification** (en) 3 MB, 09.04.2018

Code: q\_352p02

**EAC certification** (ru) 388 kB, 20.01.2016

Code: q\_1527p17\_ru

## Images

---

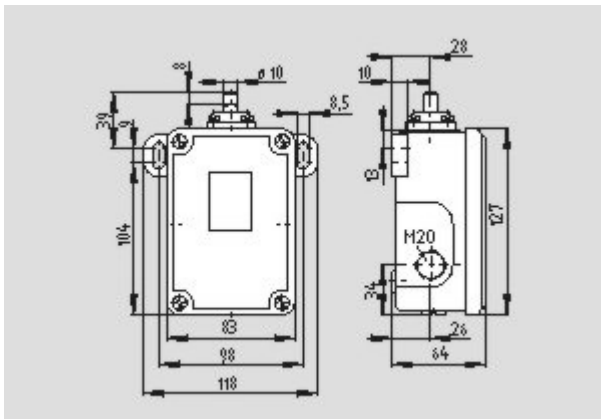

Dimensional drawing (basic component)

---

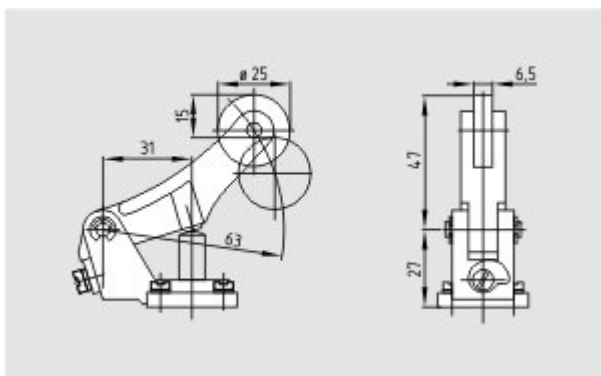

Dimensional drawing (miscellaneous)

---



Operating principle

---

K.A. Schmersal GmbH & Co. KG, Möddinghofe 30, D-42279 Wuppertal  
The data and values have been checked thoroughly. Technical modifications and errors excepted.  
Generiert am 13.02.2019 - 13:38:51h Kasbase 3.3.0.F.64I