

Datasheet - STB 1

Safety light barriers / Accessories / Mounting post

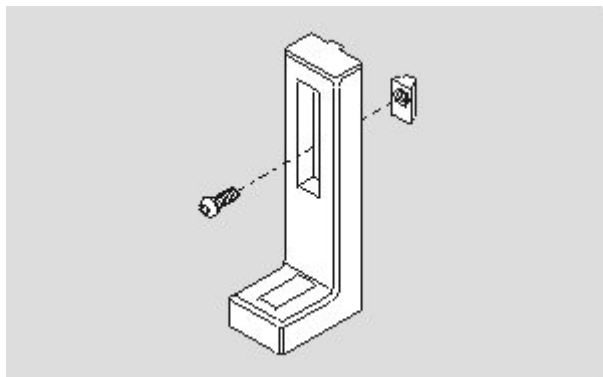

Preferred typ



(Minor differences between the printed image and the original product may exist!)

Ordering details

Product type description	STB 1
Article number	101150266
EAN Code	4030661155241
eCl@ss	27-27-92-91

Global Properties

Permanent light	Bodenständerfuß
Weight	250

Documents

Mounting and wiring instructions (de, en, fr) 267 kB, 30.08.2005

Code: m_slcp02

Images

K.A. Schmersal GmbH & Co. KG, Möddinghofe 30, D-42279 Wuppertal

The data and values have been checked thoroughly. Technical modifications and errors excepted.

Generiert am 13.02.2019 - 14:15:30h Kasbase 3.3.0.F.64I