

Datasheet - SEPK 02.0.4.0.22/95

Two-hand control panels / SEPK 02.0

 Preferred typ

- Thermoplastic enclosure
- 2 black operating buttons (positioning parts) Ø 55
- 1 Emergency Stop button in thermoplastic version
- Stand and wall mounting possible
- 2 part enclosure

(Minor differences between the printed image and the original product may exist!)

Ordering details

Product type description	SEPK 02.0.4.0.22/95
Article number	101144637
EAN Code	4030661283685
eCl@ss	27-37-12-19

Approval

Approval



Global Properties

Permanent light	SEPK 02.0
Standards	IEC/EN 60947-5-5, EN ISO 13850, EN 574
Compliance with the Directives (Y/N) 	Yes
Number of operating push buttons (positioning parts)	2
- consisting of	ADP55/3SW; RF10; RF03
Number of Emergency Stop button	1
- consisting of	ADR 40 RT; RF10; RF03
Materials	
- Material of the housings	Plastic
Housing coating	No
Weight	1932
Suitable for EMERGENCY-OFF (Y/N)	Yes
Foot (Y/N)	No
Pre-wiring on terminal block (Y/N)	No
Stepped switching (Y/N)	No
Switching block (Y/N)	No
Construction kit possible (Y/N)	Yes
Recommended combinations	SRB201ZH, SRB200ZHX1, SRB201ZHX3

Mechanical data

Connection type	Screw connection
Cable section	
- Min. Cable section	
- Max. Cable section	1.5
Mechanical life	10.000.000 operations

Ambient conditions

Protection class	IP65
------------------	------

Electrical data

Number of shutters	2
Number of openers	2
Rated insulation voltage U_i	440 V
Thermal test current I_{the}	10 A
Utilisation category	AC-15: 250 V / 8 A DC-13: 24 V / 5 A

Dimensions

Dimensions	
- Width	469 mm
- Height	185 mm
- Depth	137 mm
diameters for the actuating heads	
- Emergency stop latching pushbutton	40
- Operating push buttons (positioning parts)	55

notice

Customer-specific executions (completely pre-wired, special paint, etc.)
8 knockouts for additional operating devices \varnothing 22,3 mm
4 premachined predetermined breaking points (M25 x 1,5) for the cable gland outputs
1 NO/1 NC contact per unit, 1 NO/1 NC contact for Emergency-Stop
Emergency-Stop button KDRRKZ 40 RT
Optional: actuators with low actuating force

Keywords

Two-hand control panels

Documents

Operating instructions and Declaration of conformity (pt) 1 MB, 06.04.2017
Code: mrl_sep_pt

Operating instructions and Declaration of conformity (es) 1 MB, 16.02.2017
Code: mrl_sep_es

Operating instructions and Declaration of conformity (cn) 2 MB, 23.11.2018

Code: mrl_sep_cn

Operating instructions and Declaration of conformity (it) 1 MB, 29.06.2017

Code: mrl_sep_it

Operating instructions and Declaration of conformity (de) 1 MB, 11.01.2017

Code: mrl_sep_de

Operating instructions and Declaration of conformity (fr) 1 MB, 01.03.2017

Code: mrl_sep_fr

Operating instructions and Declaration of conformity (nl) 1 MB, 13.08.2018

Code: mrl_sep_nl

Operating instructions and Declaration of conformity (pl) 1 MB, 16.02.2017

Code: mrl_sep_pl

Operating instructions and Declaration of conformity (en) 1 MB, 11.01.2017

Code: mrl_sep_en

EAC certification (ru) 779 kB, 05.10.2015

Code: q_6043p17_ru

Images

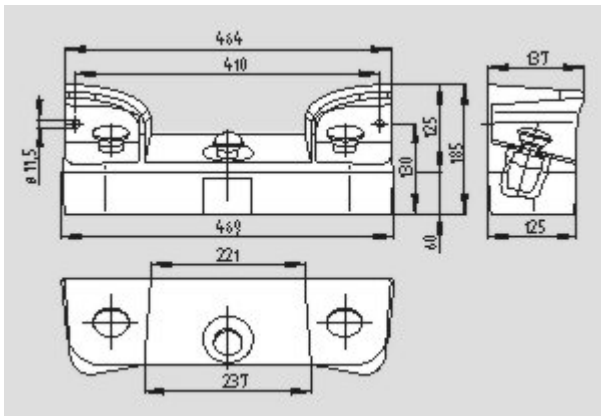

Dimensional drawing (basic component)

System components

Accessories



STPSK - \$missingName\$

- mobile sheet metal bending construction with threaded holes for floor fixation
 - with height adjustment
 - with Spacer ring
 - can be combined with operating panel SEP... and foot switches with protective shields to be used as two-hand foot-operated station
-

STPLC - \$missingName\$

- Welding construction with threaded holes for floor fixation
- without height adjustment
- without Spacer ring



- can be combined with operating panel SEP... to be used as two-hand foot-operated station



STP 02.4 - \$missingName\$

- Welding construction with threaded holes for floor fixation
- with height adjustment
- with Spacer ring



STP 02.1 - \$missingName\$

- Welding construction with threaded holes for floor fixation
- with height adjustment
- without Spacer ring



STP 01.5 - \$missingName\$

- Welding construction with threaded holes for floor fixation
- without height adjustment
- Fixation of the spacer ring by the user through fixing and welding



STP 01.4 - \$missingName\$

- Welding construction with threaded holes for floor fixation
- without height adjustment
- with Spacer ring



STP 01.1 - \$missingName\$

- Welding construction with threaded holes for floor fixation
- without height adjustment
- without Spacer ring

Safety control modules



SRB200ZHX1

- Monitoring two-hand control panels to EN 574 III A
- 2 safety contacts, STOP 0

SRB201ZHX3

- Monitoring two-hand control panels to EN 574 III C
- 2 safety contacts, STOP 0
- 1 Signalling output



SRB201ZH

- Monitoring two-hand control panels to EN 574 III C
- 2 safety contacts, STOP 0
- 1 Signalling output

K.A. Schmersal GmbH & Co. KG, Möddinghofe 30, D-42279 Wuppertal

The data and values have been checked thoroughly. Technical modifications and errors excepted.

Generiert am 13.02.2019 - 14:54:14h Kasbase 3.3.0.F.64l