

## Datasheet - EX-AZM 415-02/02ZPKA-24VAC/DC-3D



Solenoid interlock / EX-AZM 415



(Minor differences between the printed image and the original product may exist!)

- Metal enclosure
- Adjustable ball latch to 400 N
- 130 mm x 100 mm x 46.5 mm
- Clamping force 3500N
- Long life
- Ex certified
- Interlock with protection against incorrect locking.
- Robust design
- Problem-free opening of stressed doors by means of bell-crank system
- High holding force
- 2 cable entries M 20 x 1.5
- 2 switches in one enclosure
- Ex-certified screwed cable gland

### Ordering details

Product type description	EX-AZM 415-02/02ZPKA-24VAC/DC-3D
Article number	101194202
EAN Code	4030661358338
eCl@ss	27-27-26-03

### Approval

Approval	ATEX
----------	------

### Classification

Standards	EN ISO 13849-1
B10d Normally-closed contact (NC)	2.000.000
Mission time notice	20 Years
	$MTTF_d = \frac{B_{10d}}{0,1 \times n_{op}}$
	$n_{op} = \frac{d_{op} \times h_{op} \times 3600 \text{ s/h}}{t_{cycle}}$

### Global Properties

Permanent light	EX-AZM 415
Standards	EN 60079-0, EN 60079-31, EN 60947-5-1, BG-GS-ET-19
Compliance with the Directives (Y/N) 	Yes
Number of actuating directions	1
Active principle	electromechanical
Duty cycle ED	Magnet 100 %
Materials	
- Material of the housings	Aluminium
- Material of the contacts	Silver

Housing coating	painted
Weight	976

## Mechanical data

---

Design of electrical connection	Screw connection
Cable cross-section of the cable glands	
- Min. Cable cross-section of the cable glands	Ø 7
- Max. Cable cross-section of the cable glands	Ø 12
Cable section	
- Min. Cable section	0,75
- Max. Cable section	2.5
Mechanical life	> 1.000.000 operations
notice	All indications about the cable section are including the conductor ferrules.
Emergency unlocking device (Y/N)	No
Manual release (Y/N)	No
Emergency release (Y/N)	No
Latching force	80 ... 400 (adjustable)
Positive break force	15
positive break travel	5
Clamping force F	3500 N
Impact energy	4 J
Max. Actuating speed	1

## Ambient conditions

---

Ambient temperature	
- Min. environmental temperature	-10
- Max. environmental temperature	+50
Protection class	IP67

## Electrical data

---

Design of control element	Normally open contact (NO), Opener (NC)
Switching principle	Creep circuit element
Number of auxiliary contacts	0
Number of safety contacts	4
Power to unlock	No
Power to lock	Yes
Rated control voltage $U_s$	24 V AC/DC
Power consumption	max. 10 W
Rated impulse withstand voltage $U_{imp}$	4 kV
Rated insulation voltage $U_i$	250 V
Thermal test current $I_{the}$	6 A
Utilisation category	AC-15: 230 V / 4 A
Max. fuse rating	6 A gG D-fuse

## ATEX

---

EX-marking	EX II 3D Ex tc IIIC T90°C Dc X
Explosion protection categories for gases	None
Explosion protection Zones for gases	None
Explosion protected category for dusts	3D
Explosion protection Zones for dusts	22

## Dimensions

Dimensions of the sensor

- Width of sensor	130
- Height of sensor	100
- Length of sensor	46.5

## Included in delivery

Actuators must be ordered separately.

Including Ex-certified screwed cable gland and screw plug

## notice - Dimensional drawing

A setting screw Ball latch

## Keywords



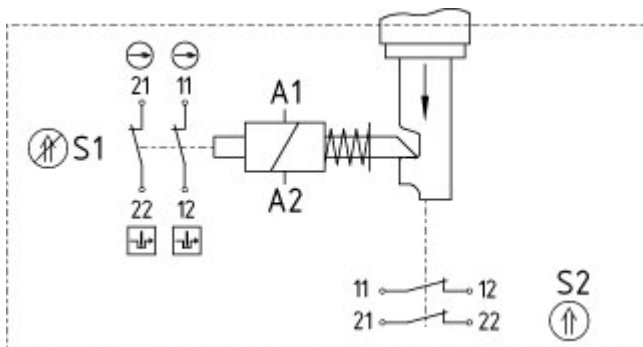

Keywords

Ex, EEx, ATEX, Ex AZM415, Ex AZM415, AZM415 Ex, AZM415ex, AZM415ex, ATEX AZM415

## Diagram



Note Diagram

-  positive break NC contact
-  active
-  no active
-  Normally-open contact
-  Normally-closed contact

## Ordering suffix

The applicable ordering suffix is added at the end of the part number of the safety switch.

Order example: EX-AZM 415-02/02ZPKA-24VAC/DC-3D-**1637**

...-**1637**

0,3 µm gold-plated contacts

## Ordering code

EX-AZM 415-(1)ZPK(2)-24VAC/DC-(3)-3D

(1)

11/11	2 Opener (NC) / 2 Normally open contact (NO)
02/11	3 Opener (NC) / 1 Normally open contact (NO)
02/20	2 Opener (NC) / 2 Normally open contact (NO)
02/02	4 Opener (NC)
(2)	
without	Power to unlock
A	Power to lock
(3)	
1637	gold-plated contacts

## Documents

---

**Operating instructions and Declaration of conformity (it)** 378 kB, 13.10.2017

Code: mrl\_ex-azm415\_it

**Operating instructions and Declaration of conformity (da)** 284 kB, 24.09.2015

Code: mrl\_ex-azm415\_da

**Operating instructions and Declaration of conformity (jp)** 572 kB, 18.01.2012

Code: mrl\_ex-azm415\_jp

**Operating instructions and Declaration of conformity (pt)** 382 kB, 13.10.2017

Code: mrl\_ex-azm415\_pt

**Operating instructions and Declaration of conformity (de)** 363 kB, 28.09.2017

Code: mrl\_ex-azm415\_de

**Operating instructions and Declaration of conformity (es)** 381 kB, 10.10.2017

Code: mrl\_ex-azm415\_es

**Operating instructions and Declaration of conformity (sv)** 282 kB, 17.02.2014

Code: mrl\_ex-azm415\_sv

**Operating instructions and Declaration of conformity (fr)** 384 kB, 13.10.2017

Code: mrl\_ex-azm415\_fr

**Operating instructions and Declaration of conformity (en)** 370 kB, 28.09.2017

Code: mrl\_ex-azm415\_en

**Operating instructions and Declaration of conformity (nl)** 399 kB, 07.08.2018

Code: mrl\_ex-azm415\_nl

**Operating instructions and Declaration of conformity (pl)** 417 kB, 01.02.2018

Code: mrl\_ex-azm415\_pl

**Brochure (de)** 7 MB, 19.10.2016

Code: b\_atep01\_de

## Images

---

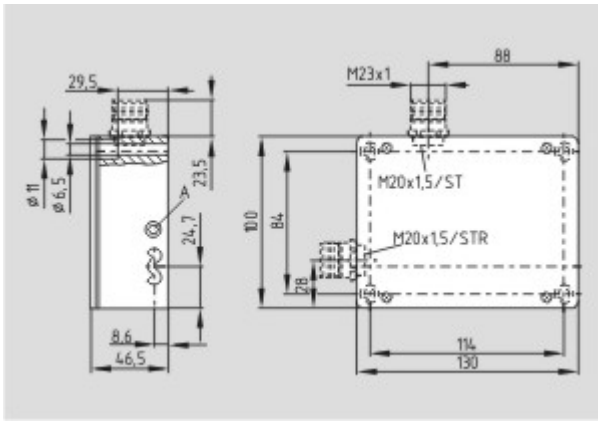

Dimensional drawing (basic component)

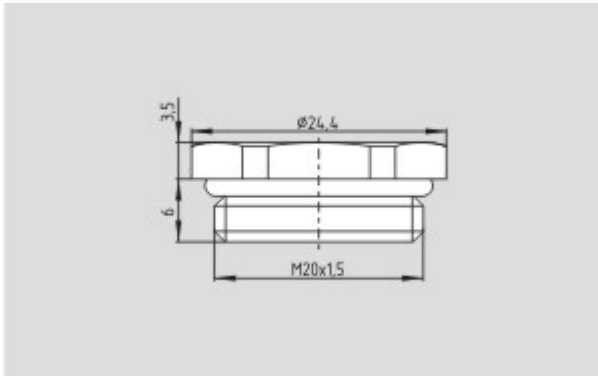

Dimensional drawing (miscellaneous)

## System components

### Actuator



#### 1128545 - AZ/AZM 415-B1

- For sliding doors
- Actuators with return spring
- Tolerates up to max. 6 mm overtravel



#### 1144797 - AZ/AZM 415-B3

- Particularly suitable for hinged guards
- For very small actuating radii at 90° to the plane of the actuator



#### 1144796 - AZ/AZM 415-B2

- Particularly suitable for hinged guards
- For very small actuating radii in line with the plane of the actuator