

Datasheet - Mounting set MS AZ 17 P

Safety switch with separate actuator / AZ 17 / Accessories AZ 17

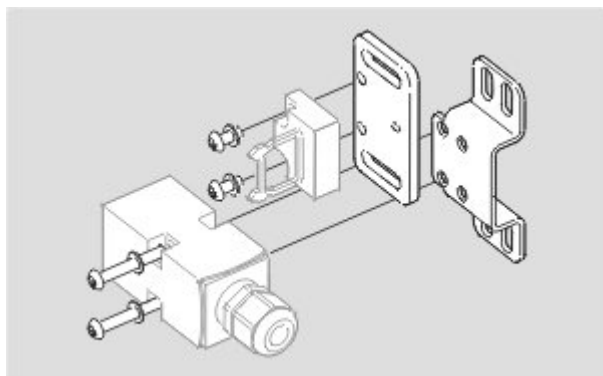

(Minor differences between the printed image and the original product may exist!)

Ordering details

Product type description	Montagebausatz MS AZ 17 P
Article number	101150363
EAN Code	4030661287744
eCl@ss	27-27-92-91

Global Properties

Permanent light	Montagebausatz
Weight	115

Mechanical data

mounting	Mounting parallel to safety guard
----------	-----------------------------------

notice

The mounting sets can only be used in conjunction with actuator AZ 17-B6.

Included in delivery

Included in delivery

- Roundhead screw M 4 x 30 per ISO 7380
- Roundhead screw M 4 x 10 per ISO 7380
- Washer DIN 433-4,3
- U-profile AZ 17
- Mounting angle AZ 17
- Mounting plate AZ 17/AZM 170

Documents

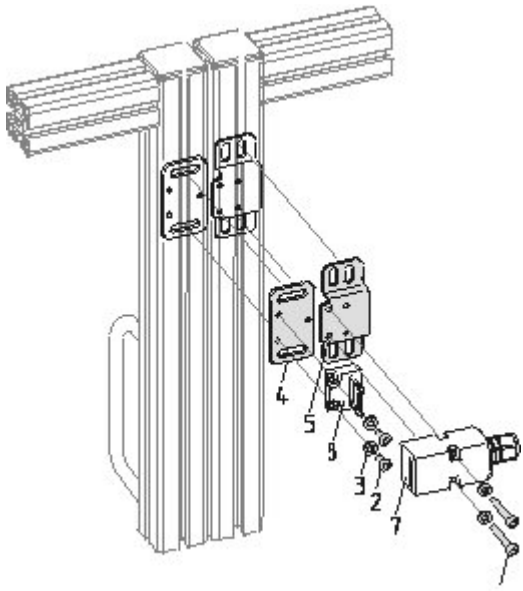

Product graph (exploded-view drawing)

K.A. Schmersal GmbH & Co. KG, Möddinghofe 30, D-42279 Wuppertal

The data and values have been checked thoroughly. Technical modifications and errors excepted.

Generiert am 13.02.2019 - 14:36:44h Kasbase 3.3.0.F.64I