

Datasheet - MS MZM 100-W

Solenoid interlock / MZM 100 / Accessories



Preferred typ



(Minor differences between the printed image and the original product may exist!)

Ordering details

Product type description	MS MZM 100-W
Article number	101185510
EAN Code	4030661343464
eCl@ss	27-27-92-91

Global Properties

Permanent light	Montagebausatz
Weight	210

Dimensions

Dimensions	
- Width	63 mm
- Height	120 mm
- Depth	44 mm

Included in delivery

Mounting angle	1 piece
Cylinder head screw with hexagonal M6 x 40	2 piece

Documents

Operating instructions and Declaration of conformity (cs) 199 kB, 24.09.2018

Code: mrl_ms_mzm100_cs

Operating instructions and Declaration of conformity (pt) 159 kB, 24.09.2018

Code: mrl_ms_mzm100_pt

Operating instructions and Declaration of conformity (cn) 250 kB, 23.11.2018

Code: mrl_ms_mzm100_cn

Operating instructions and Declaration of conformity (nl) 162 kB, 24.09.2018

Code: mrl_ms_mzm100_nl

Operating instructions and Declaration of conformity (jp) 242 kB, 24.09.2018

Code: mrl_ms_mzm100_jp

Operating instructions and Declaration of conformity (it) 158 kB, 24.09.2018

Code: mrl_ms_mzm100_it

Operating instructions and Declaration of conformity (en) 160 kB, 24.09.2018

Code: mrl_ms_mzm100_en

Operating instructions and Declaration of conformity (de) 160 kB, 24.09.2018

Code: mrl_ms_mzm100_de

Operating instructions and Declaration of conformity (fr) 159 kB, 24.09.2018

Code: mrl_ms_mzm100_fr

Images

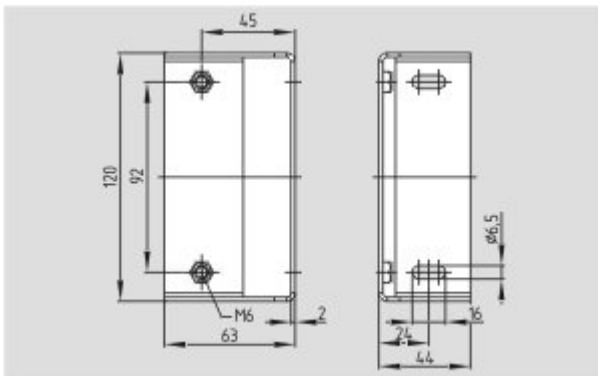

Dimensional drawing (miscellaneous)

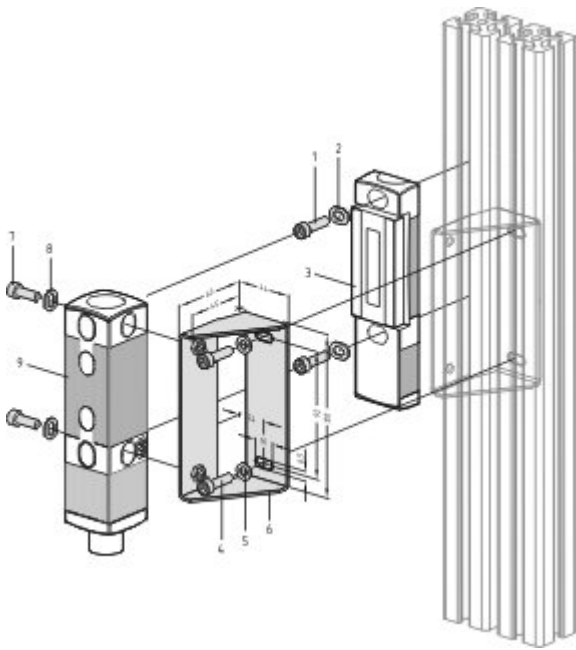

Product graph (exploded-view drawing)



Illustration